

# Application Notes and Protocols: Nitroso-PSAP Assay for Non-Protein-Bound Iron

**Author:** BenchChem Technical Support Team. **Date:** April 2026

## Compound of Interest

Compound Name: Nitroso-PSAP

CAS No.: 80459-15-0

Cat. No.: B1598662

[Get Quote](#)

For Researchers, Scientists, and Drug Development Professionals

## Introduction

The determination of non-protein-bound iron, often referred to as the labile iron pool (LIP), is crucial in various fields of biomedical research and drug development. The LIP consists of redox-active iron that is loosely bound within the cell and can catalyze the formation of reactive oxygen species (ROS), leading to cellular damage. An imbalance in the LIP is implicated in numerous pathological conditions and is a key factor in ferroptosis, a form of regulated cell death. The **Nitroso-PSAP** assay is a sensitive and direct colorimetric method for the quantitative determination of non-protein-bound iron in a variety of biological samples.

This document provides detailed application notes and protocols for the **Nitroso-PSAP** assay, intended to guide researchers in accurately measuring non-protein-bound iron.

## Principle of the Assay

The **Nitroso-PSAP** (2-Nitroso-5-(N-propyl-N-sulfopropylamino)phenol) assay is based on a direct colorimetric reaction. The core principle involves the following steps:

- **Dissociation and Reduction:** In a weakly acidic buffer containing a denaturing agent, iron bound to transport proteins like transferrin is dissociated.[1][2][3] Any ferric iron ( $\text{Fe}^{3+}$ ) present is then reduced to ferrous iron ( $\text{Fe}^{2+}$ ) by a reducing agent in the reaction mixture.[3][4]
- **Chelation and Color Formation:** The resulting ferrous ions ( $\text{Fe}^{2+}$ ) react with the chromogen, **Nitroso-PSAP**, to form a stable, water-soluble blue-green chelate complex.[1][3][5]
- **Spectrophotometric Quantification:** The intensity of the colored complex is directly proportional to the concentration of iron in the sample. The absorbance is measured spectrophotometrically at a wavelength of approximately 750 nm (acceptable range: 730-770 nm).[1][2]

## Assay Performance Characteristics

The **Nitroso-PSAP** assay is a robust method with performance characteristics suitable for research and drug development applications. The following tables summarize typical quantitative data for the assay. Actual performance may vary depending on the specific kit, instrumentation, and laboratory conditions.

### Table 1: Assay Linearity and Sensitivity

Parameter	Typical Value	Description
Assay Range	10 - 1000 µg/dL	The range of iron concentrations over which the assay is accurate and precise.
Linearity (r <sup>2</sup> )	> 0.99	The coefficient of determination for the linear regression of the standard curve.
Limit of Detection (LOD)	~4 µg/L	The lowest concentration of iron that can be reliably detected above the blank.
Molar Absorptivity (ε)	~4.5 x 10 <sup>4</sup> L·mol <sup>-1</sup> ·cm <sup>-1</sup> at 756 nm	A measure of how strongly the Fe(II)-Nitroso-PSAP complex absorbs light at the specified wavelength. <a href="#">[6]</a> <a href="#">[7]</a>

## Table 2: Assay Precision

Parameter	Typical Coefficient of Variation (CV%)	Description
Intra-Assay Precision	< 8%	The variation observed within a single assay run, using the same sample.
Inter-Assay Precision	< 10%	The variation observed between different assay runs on different days, using the same sample.

## Table 3: Recovery

Sample Type	Spiked Concentration	Typical Recovery (%)
Serum	Low, Medium, High	90 - 110%
Cell Lysate	Low, Medium, High	85 - 115%

## Experimental Protocols

### A. Reagent Preparation

- Bring all reagents to room temperature before use.
- Working Reagent Preparation: Prepare the working reagent by mixing the components as specified in the kit manual. The working reagent is typically stable for a limited time, so prepare it fresh before each assay run.

### B. Sample Preparation

Proper sample preparation is critical for accurate results. The following are general guidelines for various sample types.

Important Considerations:

- Use disposable, iron-free plasticware to avoid contamination.
- Glassware, if used, should be washed with 1M HCl or 1M HNO<sub>3</sub> followed by thorough rinsing with distilled, deionized water.[\[2\]](#)[\[3\]](#)
- EDTA: Do not use plasma samples collected with EDTA, as it is a strong iron chelator and will interfere with the assay.[\[2\]](#)[\[8\]](#)
- Heme Iron: This assay does not measure heme-containing iron species.[\[2\]](#)

#### 1. Serum and Plasma (Heparin or Citrate):

- Collect blood and process to obtain serum or plasma according to standard procedures.
- If the sample is turbid or contains insoluble substances, centrifuge at 6,000 rpm for 15 minutes.[\[2\]](#)
- Use the clear supernatant for the assay.

#### 2. Cell Lysates:

- Harvest cells and wash with ice-cold PBS.

- Resuspend the cell pellet in a non-chelating lysis buffer. Avoid buffers containing EDTA.
- Homogenize or sonicate the cells on ice.
- Centrifuge the lysate at 10,000 x g for 15 minutes at 4°C to pellet cellular debris.
- Collect the supernatant for the assay. If the supernatant is turbid, a further centrifugation at 6,000 rpm for 15 minutes is recommended.[2]
- For some samples, adjusting the pH to 2.0-3.0 with 6M HCl (e.g., 5-10 µL per 1 mL of lysate) may be necessary.[2]

### 3. Tissue Homogenates:

- Weigh the tissue sample and homogenize in a suitable buffer on ice.
- Add 5% trichloroacetic acid (TCA) solution to the homogenate, vortex for 1 minute, and incubate at 4-8°C for 30 minutes.[2]
- Centrifuge at 6,000 rpm for 15 minutes.[2]
- Collect the clear supernatant for the assay. The sample pH should be between 2.0 and 8.0.  
[2]

## C. Assay Procedure (96-well plate format)

- Standard Curve Preparation: Prepare a series of iron standards according to the kit instructions. Use purified water as the blank (0 µg/dL).
- Sample Addition: Add 15 µL of blank, standards, and prepared samples to individual wells of the microplate.[2]
- Buffer A Addition: Add 160 µL of Buffer A to each well. Mix gently by pipetting up and down. Avoid foaming.[2]
- First Incubation: Incubate the plate at room temperature for 10 minutes.[2]

- Working Reagent Addition: Add 75  $\mu$ L of the freshly prepared Working Reagent to each well. Mix gently.
- Second Incubation: Incubate the plate at room temperature for 5 minutes to allow for color development.[2]
- Absorbance Measurement: Read the absorbance at 750 nm using a microplate reader.[2]

## D. Data Analysis

- Subtract the absorbance of the blank from the absorbance of all standards and samples.
- Plot a standard curve of the blank-corrected absorbance values of the standards versus their corresponding iron concentrations.
- Determine the iron concentration of the samples by interpolating their absorbance values from the standard curve.
- If samples were diluted, multiply the calculated concentration by the dilution factor.

## Visualizations

### Assay Principle and Workflow

## Nitroso-PSAP Assay Workflow

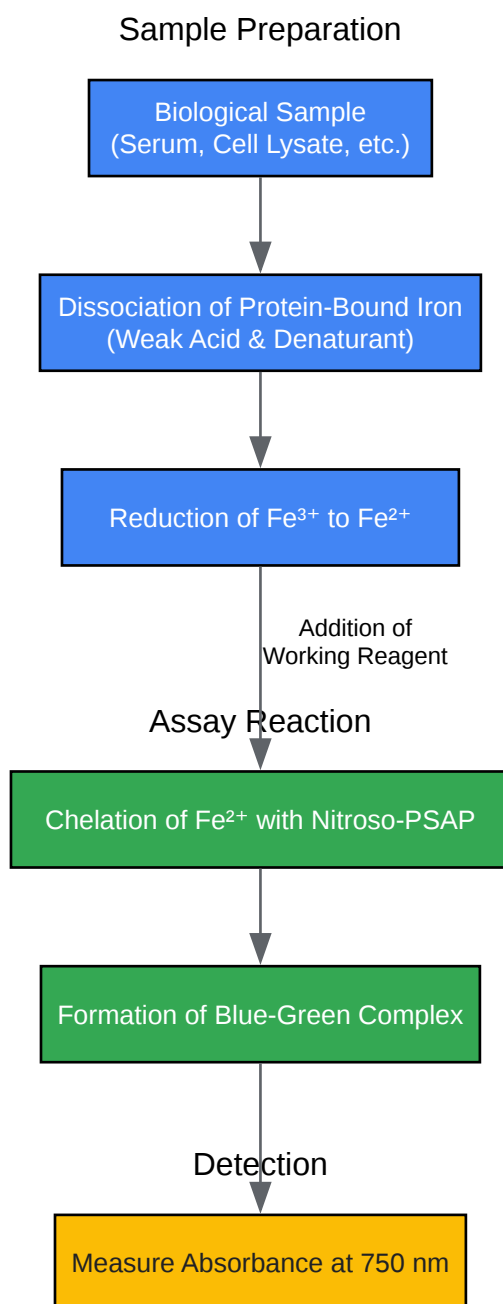

[Click to download full resolution via product page](#)

Caption: Workflow of the **Nitroso-PSAP** assay.

## Chemical Reaction of Nitroso-PSAP with Ferrous Iron

## Nitroso-PSAP Chelation of Ferrous Iron

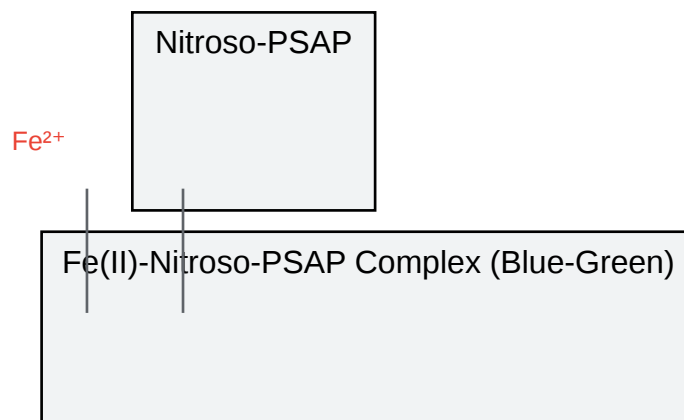

[Click to download full resolution via product page](#)

Caption: Chelation of ferrous iron by **Nitroso-PSAP**.

## Role of Labile Iron Pool in Ferroptosis Signaling

Drug Development Target

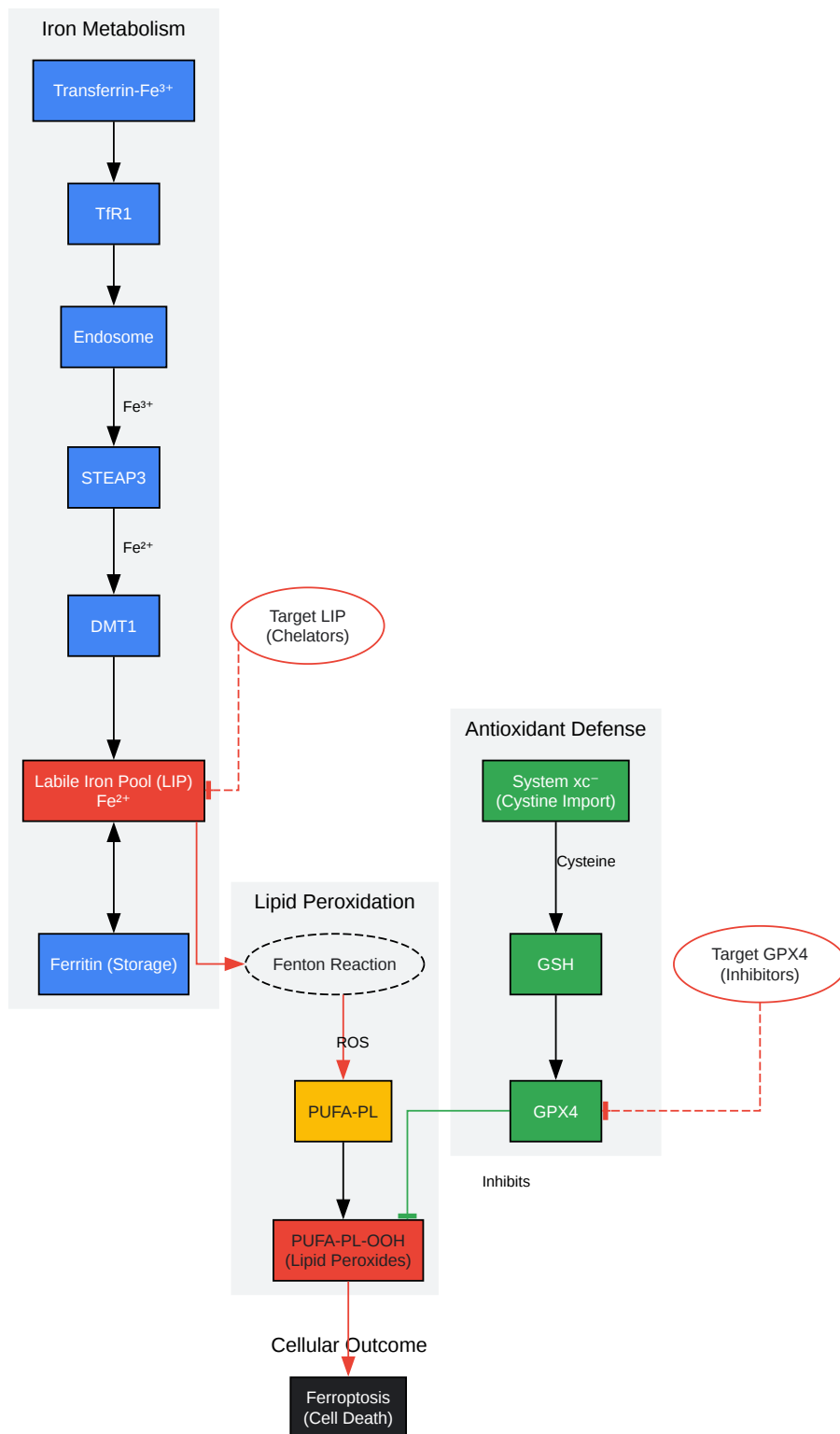

[Click to download full resolution via product page](#)

Caption: Role of labile iron in ferroptosis.

## Troubleshooting

Issue	Possible Cause(s)	Suggested Solution(s)
Low or no color development	<ul style="list-style-type: none"><li>- Reagents expired or improperly stored.</li><li>- Incorrect wavelength used for measurement.</li><li>- Iron concentration is below the detection limit.</li></ul>	<ul style="list-style-type: none"><li>- Check reagent expiration dates and storage conditions.</li><li>- Ensure the spectrophotometer is set to 750 nm.</li><li>- Concentrate the sample if possible, or use a more sensitive method.</li></ul>
High background absorbance	<ul style="list-style-type: none"><li>- Contaminated reagents or water.</li><li>- Contaminated labware.</li></ul>	<ul style="list-style-type: none"><li>- Use fresh, high-purity water and reagents.</li><li>- Use acid-washed or new disposable labware.</li></ul>
Poor reproducibility	<ul style="list-style-type: none"><li>- Inaccurate pipetting.</li><li>- Inconsistent incubation times or temperatures.</li><li>- Foaming during mixing.</li></ul>	<ul style="list-style-type: none"><li>- Calibrate pipettes and use proper pipetting technique.</li><li>- Ensure consistent timing and temperature for all wells.</li><li>- Mix gently to avoid bubble formation.</li></ul>
Results are unexpectedly low	<ul style="list-style-type: none"><li>- Presence of chelating agents (e.g., EDTA) in the sample.</li></ul>	<ul style="list-style-type: none"><li>- Recollect samples using appropriate anticoagulants (heparin, citrate) or in plain tubes.</li></ul>

## Conclusion

The **Nitroso-PSAP** assay provides a reliable and straightforward method for the quantification of non-protein-bound iron. Its application is particularly relevant for researchers and drug development professionals investigating conditions associated with iron dysregulation and exploring therapeutic strategies that target the labile iron pool, such as in the context of ferroptosis. By following the detailed protocols and considering the potential for interferences, users can obtain accurate and reproducible data to advance their research.

### Need Custom Synthesis?

BenchChem offers custom synthesis for rare earth carbides and specific isotopic labeling.

Email: [info@benchchem.com](mailto:info@benchchem.com) or [Request Quote Online](#).

## References

- [1. researchgate.net \[researchgate.net\]](#)
- [2. researchgate.net \[researchgate.net\]](#)
- [3. Mechanism of Ferroptosis and Its Role in Disease Development - PMC \[pmc.ncbi.nlm.nih.gov\]](#)
- [4. Ferroptosis regulates key signaling pathways in gastrointestinal tumors: Underlying mechanisms and therapeutic strategies - PMC \[pmc.ncbi.nlm.nih.gov\]](#)
- [5. mdpi.com \[mdpi.com\]](#)
- [6. Synthetic and Mechanistic Studies into the Reductive Functionalization of Nitro Compounds Catalyzed by an Iron\(salen\) Complex - PMC \[pmc.ncbi.nlm.nih.gov\]](#)
- [7. cusabio.com \[cusabio.com\]](#)
- [8. kamiyabiomedical.com \[kamiyabiomedical.com\]](#)
- To cite this document: BenchChem. [Application Notes and Protocols: Nitroso-PSAP Assay for Non-Protein-Bound Iron]. BenchChem, [2026]. [Online PDF]. Available at: [\[https://www.benchchem.com/product/b1598662/docs#application-notes-and-protocols-nitroso-psap-assay-for-non-protein-bound-iron\]](https://www.benchchem.com/product/b1598662/docs#application-notes-and-protocols-nitroso-psap-assay-for-non-protein-bound-iron)

---

### Disclaimer & Data Validity:

The information provided in this document is for Research Use Only (RUO) and is strictly not intended for diagnostic or therapeutic procedures. While BenchChem strives to provide accurate protocols, we make no warranties, express or implied, regarding the fitness of this product for every specific experimental setup.

**Technical Support:** The protocols provided are for reference purposes. Unsure if this reagent suits your experiment?

**Need Industrial/Bulk Grade?** [Request Custom Synthesis Quote](#)

# BenchChem

Our mission is to be the trusted global source of essential and advanced chemicals, empowering scientists and researchers to drive progress in science and industry.

## Contact

Address: 3281 E Guasti Rd

Ontario, CA 91761, United States

Phone: (601) 213-4426

Email: [info@benchchem.com](mailto:info@benchchem.com)

[Contact our Ph.D. Support Team for a compatibility check](#)