

"biological activity of piperidine-based compounds"

Author: BenchChem Technical Support Team. **Date:** May 2026

Compound of Interest

Compound Name: *4-(4-bromobutyl)piperidine Hydrobromide*
CAS No.: *1049728-90-6*
Cat. No.: *B1597220*

[Get Quote](#)

Biological Activity of Piperidine-Based Compounds: A Technical Guide

Executive Summary: The Privileged Scaffold

The piperidine ring (

) is a saturated, six-membered heterocyclic amine that stands as one of the most ubiquitous "privileged scaffolds" in medicinal chemistry.[1] Its structural ubiquity stems from its conformational flexibility (chair/boat conformations) and its ability to function as a versatile pharmacophore linker, facilitating precise orientation of functional groups to interact with biological targets such as G-protein coupled receptors (GPCRs), enzymes (kinases, cholinesterases), and ion channels.[1]

This guide dissects the biological activity of piperidine derivatives, moving beyond basic listing to explore the mechanistic causality of their efficacy in Oncology, Neurology, and Infectious Diseases.

Structural Activity Relationship (SAR) Logic

The biological success of piperidine lies in its ability to be functionalized at three critical vectors. The following diagram illustrates the SAR logic governing piperidine optimization.

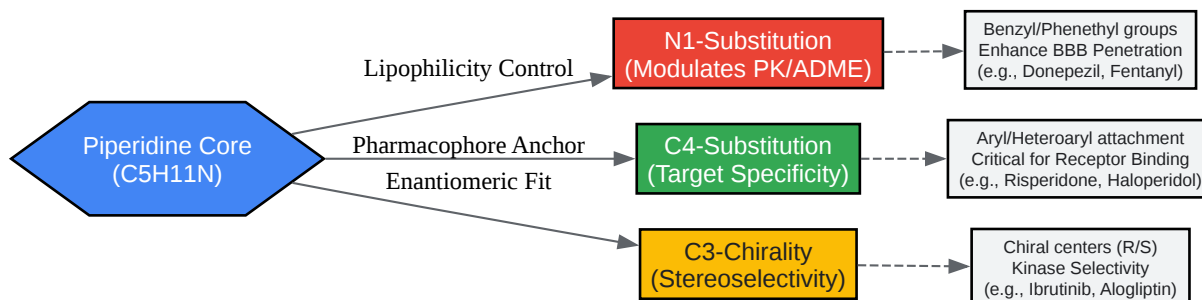

[Click to download full resolution via product page](#)

Figure 1: SAR Logic of the Piperidine Scaffold. The N1 position regulates bioavailability and blood-brain barrier (BBB) penetration, while C4 and C3 positions dictate target affinity and selectivity.

Therapeutic Areas & Mechanistic Causality[2] Central Nervous System (CNS)

Piperidine's lipophilicity (logP modulation via N-substitution) allows for efficient BBB traversal, making it a cornerstone in CNS drug design.[1]

- Alzheimer's Disease (AChE Inhibition):
 - Drug: Donepezil.[1][2][3][4][5]
 - Mechanism:[6][7][8][9][10] The N-benzylpiperidine moiety mimics acetylcholine.[1][6][11] The positively charged nitrogen binds to the anionic subsite (Trp86) of Acetylcholinesterase (AChE), while the benzyl group interacts with the peripheral anionic site (PAS), blocking substrate entry.
- Antipsychotics (Dopamine/Serotonin Antagonism):

- Drug:Risperidone.[1]
- Mechanism:[6][7][8][9][10] The piperidine ring acts as a rigid spacer, positioning the benzisoxazole and pyrimidinone rings to simultaneously block

and

receptors.[1]
- Analgesics (Opioid Receptor Agonism):
 - Drug:Fentanyl.[1]
 - Mechanism:[6][7][8][9][10] The 4-anilidopiperidine structure is critical for high-affinity binding to the

-opioid receptor.[6] The N-phenethyl group fits into a hydrophobic pocket, conferring potency 100x that of morphine.[1]

Oncology (Kinase Inhibition)

In oncology, piperidine rings often serve as "solubilizing tails" that protrude into the solvent-exposed regions of the ATP-binding pocket, improving drug solubility and pharmacokinetic properties.

- ALK Inhibitors:
 - Drug:Crizotinib, Ceritinib.[1]
 - Mechanism:[6][7][8][9][10] The piperidine ring interacts with the solvent front of the Anaplastic Lymphoma Kinase (ALK), stabilizing the inhibitor-enzyme complex.
- BTK Inhibitors:
 - Drug:Ibrutinib.[1][10][12][13]
 - Mechanism:[6][7][8][9][10] Contains a piperidine ring fused with an acrylamide warhead.[1][13] The piperidine directs the warhead to form a covalent bond with Cys481 in Bruton's Tyrosine Kinase (BTK).

Metabolic Disorders

- DPP-4 Inhibition:
 - Drug:Alogliptin.[1][8]
 - Mechanism:[6][7][8][9][10] A 3-aminopiperidine scaffold binds to the active site of Dipeptidyl Peptidase-4 (DPP-4).[6][14] The primary amine forms a crucial salt bridge with Glu205/Glu206, preventing the degradation of GLP-1.[1]

Quantitative Data Summary

Therapeutic Class	Drug Example	Target	Piperidine Role	Binding Affinity / IC50
CNS (Alzheimer's)	Donepezil	AChE	Anionic site binding (cation-)	
CNS (Analgesic)	Fentanyl	-Opioid	Hydrophobic pocket fit	
Oncology (ALK)	Ceritinib	ALK Kinase	Solvent interaction / Solubility	
Oncology (BTK)	Ibrutinib	BTK	Scaffold for covalent warhead	
Metabolic	Alogliptin	DPP-4	Salt bridge formation	

Experimental Protocol: AChE Inhibition Assay

This protocol describes the evaluation of a novel piperidine derivative for Acetylcholinesterase (AChE) inhibition using the modified Ellman's method. This is a standard self-validating protocol for CNS-targeted piperidines.[1][6]

Objective: Determine the

of Compound X (piperidine derivative).

Reagents:

- Phosphate Buffer (0.1 M, pH 8.0).[1]
- DTNB (5,5'-dithiobis-(2-nitrobenzoic acid)) – The colorimetric reagent.[6]
- ATCI (Acetylthiocholine iodide) – The substrate.[1]
- AChE enzyme (from *Electrophorus electricus*).[1]
- Positive Control: Donepezil.[1][2]

Workflow Diagram:

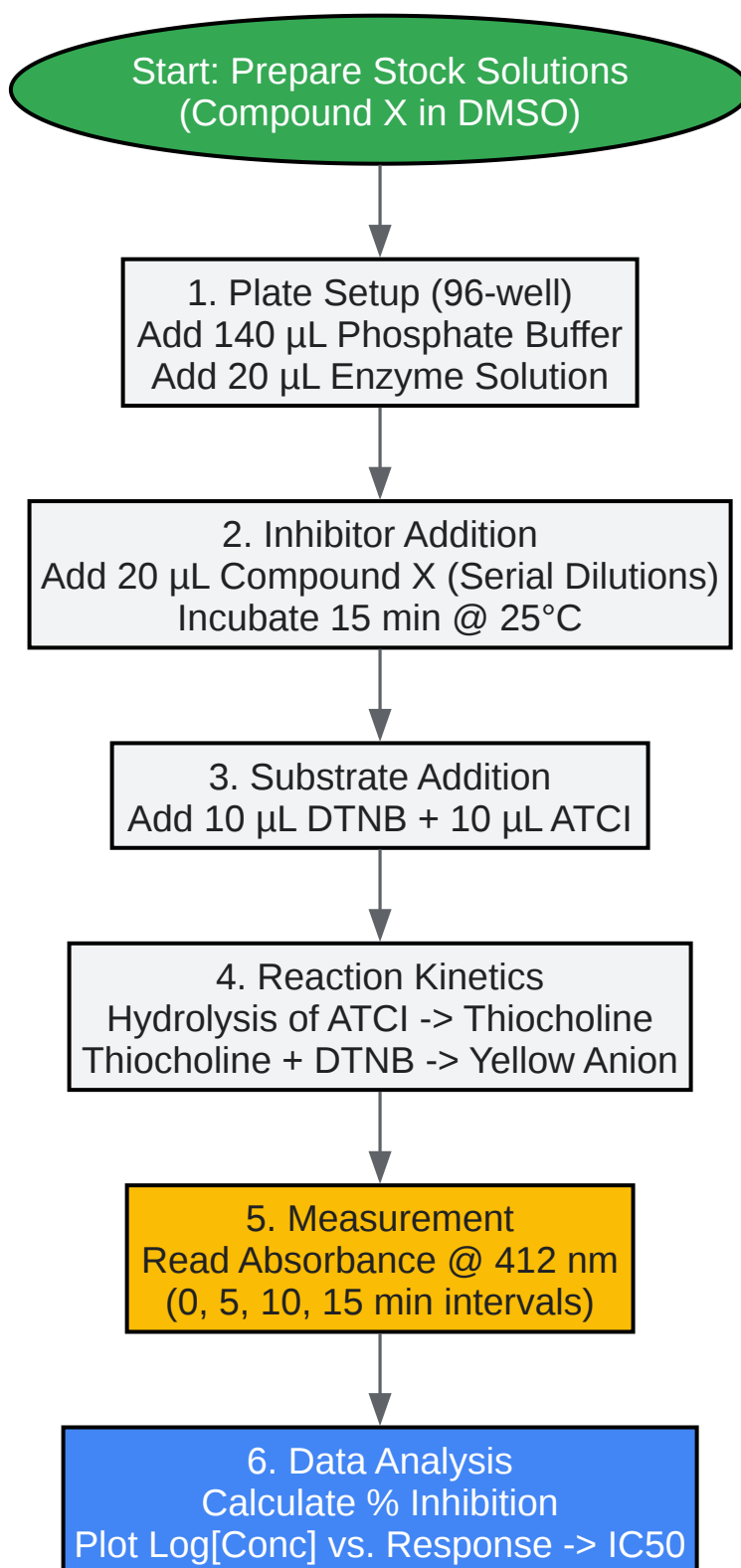

[Click to download full resolution via product page](#)

Figure 2: Workflow for Ellman's AChE Inhibition Assay.

Step-by-Step Methodology:

- Preparation: Dissolve the piperidine derivative in DMSO to create a 10 mM stock. Prepare serial dilutions (e.g.,

to

M) in phosphate buffer.
- Incubation: In a 96-well microplate, add 140 μL of phosphate buffer (pH 8.0) and 20 μL of AChE enzyme solution (0.05 U/mL). Add 20 μL of the test compound solution. Incubate for 15 minutes at 25°C to allow equilibrium binding.
- Initiation: Add 10 μL of DTNB (10 mM) and 10 μL of ATCI (15 mM substrate).
- Detection: The enzyme hydrolyzes ATCI to thiocholine, which reacts with DTNB to form the yellow 5-thio-2-nitrobenzoate anion.[1][6]
- Measurement: Monitor absorbance at 412 nm every minute for 15 minutes using a microplate reader.
- Validation:
 - Blank: Buffer + Reagents (no enzyme).[1]
 - Control: Enzyme + Substrate (no inhibitor) = 100% Activity.[1]
 - Reference: Donepezil (Standard check).[1]

References

- Review of Piperidine in Oncology
 - Title: Anticancer Potential of Piperidine Containing Small Molecule Targeted Therapeutics. [1][15]
 - Source: ResearchGate (2024).[1]

- URL:[\[Link\]](#)
- Piperidine in FDA Approved Drugs
 - Title: Piperidine-containing drugs and recently studied analogs - biological activity, mechanism of action and synthetic cascade access to their scaffolds.[\[1\]](#)[\[6\]](#)
 - Source: PubMed / NIH (2025).[\[1\]](#)
 - URL:[\[Link\]](#)
- AChE Inhibition Mechanism (Donepezil)
 - Title: Donepezil: A review of the recent structural modifications and their impact on anti-Alzheimer activity.[\[1\]](#)[\[4\]](#)[\[11\]](#)
 - Source: SciELO.[\[1\]](#)
 - URL:[\[Link\]](#)[\[16\]](#)[\[17\]](#)
- Crizotinib Structure & Mechanism
 - Title: Crizotinib | PubChem.[\[1\]](#)
 - Source: NIH National Library of Medicine.[\[1\]](#)
 - URL:[\[Link\]](#)
- Fentanyl Structure-Activity Relationship
 - Title: Fentanyl Structure as a Scaffold for Opioid/Non-Opioid Multitarget Analgesics.[\[1\]](#)
 - Source: PMC / NIH.[\[1\]](#)
 - URL:[\[Link\]](#)

Need Custom Synthesis?

BenchChem offers custom synthesis for rare earth carbides and specific isotopic labeling.

Email: info@benchchem.com or [Request Quote Online](#).

Sources

- [1. Piperidine - Wikipedia \[en.wikipedia.org\]](#)
- [2. semanticscholar.org \[semanticscholar.org\]](#)
- [3. researchgate.net \[researchgate.net\]](#)
- [4. scielo.br \[scielo.br\]](#)
- [5. researchgate.net \[researchgate.net\]](#)
- [6. Donepezil | C₂₄H₂₉NO₃ | CID 3152 - PubChem \[pubchem.ncbi.nlm.nih.gov\]](#)
- [7. Crizotinib - Wikipedia \[en.wikipedia.org\]](#)
- [8. Alogliptin | C₁₈H₂₁N₅O₂ | CID 11450633 - PubChem \[pubchem.ncbi.nlm.nih.gov\]](#)
- [9. Crizotinib | C₂₁H₂₂Cl₂FN₅O | CID 11626560 - PubChem \[pubchem.ncbi.nlm.nih.gov\]](#)
- [10. Ibrutinib - Wikipedia \[en.wikipedia.org\]](#)
- [11. The recent development of donepezil structure-based hybrids as potential multifunctional anti-Alzheimer's agents: highlights from 2010 to 2020 - RSC Advances \(RSC Publishing\) DOI:10.1039/D1RA03718H \[pubs.rsc.org\]](#)
- [12. ibrutinib | Ligand page | IUPHAR/BPS Guide to PHARMACOLOGY \[guidetopharmacology.org\]](#)
- [13. Ibrutinib | C₂₅H₂₄N₆O₂ | CID 24821094 - PubChem \[pubchem.ncbi.nlm.nih.gov\]](#)
- [14. BJOC - Synthesis of a novel analogue of DPP-4 inhibitor Alogliptin: Introduction of a spirocyclic moiety on the piperidine ring \[beilstein-journals.org\]](#)
- [15. Synthesis and anticancer activities of ceritinib analogs modified in the terminal piperidine ring - PubMed \[pubmed.ncbi.nlm.nih.gov\]](#)
- [16. Fentanyl Structure as a Scaffold for Opioid/Non-Opioid Multitarget Analgesics - PMC \[pmc.ncbi.nlm.nih.gov\]](#)
- [17. mdpi.com \[mdpi.com\]](#)

- To cite this document: BenchChem. ["biological activity of piperidine-based compounds"]. BenchChem, [2026]. [Online PDF]. Available at: [<https://www.benchchem.com/product/b1597220/docs#biological-activity-of-piperidine-based-compounds>]

Disclaimer & Data Validity:

The information provided in this document is for Research Use Only (RUO) and is strictly not intended for diagnostic or therapeutic procedures. While BenchChem strives to provide accurate protocols, we make no warranties, express or implied, regarding the fitness of this product for every specific experimental setup.

Technical Support: The protocols provided are for reference purposes. Unsure if this reagent suits your experiment?

Need Industrial/Bulk Grade? [Request Custom Synthesis Quote](#)

BenchChem

Our mission is to be the trusted global source of essential and advanced chemicals, empowering scientists and researchers to drive progress in science and industry.

Contact

Address: 3281 E Guasti Rd
Ontario, CA 91761, United States
Phone: (601) 213-4426
Email: info@benchchem.com

[Contact our Ph.D. Support Team for a compatibility check](#)