

Technical Monograph: Benzyl(2-hydroxyethyl)dimethylammonium Chloride (CAS 7221-40-1)[1]

Author: BenchChem Technical Support Team. **Date:** May 2026

Compound of Interest

Compound Name:	Benzyl(2-hydroxyethyl)dimethylammonium chloride
CAS No.:	7221-40-1
Cat. No.:	B1597992

[Get Quote](#)

Part 1: Executive Summary

Benzyl(2-hydroxyethyl)dimethylammonium chloride (CAS 7221-40-1), often referred to as BDHEA Chloride, is a specialized quaternary ammonium compound (QAC) characterized by a unique amphiphilic structure containing a lipophilic benzyl tail, a hydrophilic hydroxyethyl arm, and a cationic nitrogen core.[1] Unlike generic QACs (e.g., Benzalkonium chloride) used primarily as biocides, BDHEA Chloride is valued for its specific utility as a Phase Transfer Catalyst (PTC) in organic synthesis and a high-performance leveling agent in electrochemical deposition.[1]

In drug development, this molecule serves as a critical structural analog to choline (specifically benzylcholine derivatives), functioning as a biochemical probe for cholinergic receptor studies. Its hydroxyethyl moiety allows for further functionalization, making it a versatile intermediate for synthesizing complex cationic monomers and pharmaceutical precursors.

Part 2: Chemical Identity & Physicochemical Profile[1][2]

Nomenclature & Identification

Parameter	Detail
CAS Number	7221-40-1
IUPAC Name	Benzyl(2-hydroxyethyl)dimethylazanium chloride
Common Synonyms	Benzyldimethyl(2-hydroxyethyl)ammonium chloride; BDHEA Chloride; Benzyl-choline analog
Molecular Formula	C ₁₁ H ₁₈ ClNO
Molecular Weight	215.72 g/mol
SMILES	C(CCO)CC1=CC=CC=C1.[Cl-]

Physical Properties

Property	Value	Context
Appearance	White to off-white crystalline solid	Hygroscopic nature requires dry storage.[1]
Melting Point	75–78 °C	Sharp melting point indicates high purity potential.[1]
Solubility	High (Water, Ethanol, Methanol)	The hydroxyethyl group significantly enhances aqueous solubility compared to benzyltrimethylammonium salts.
pH (10% aq)	~5.0 – 7.0	Neutral to slightly acidic in solution.[1]

Part 3: Synthesis & Manufacturing Protocol

Reaction Mechanism

The synthesis follows a classic Menshutkin reaction (SN2 nucleophilic substitution), where the tertiary amine (N,N-Dimethylaminoethanol) attacks the benzylic carbon of Benzyl Chloride.

Reagents:

- Benzyl Chloride (BnCl): Electrophile (Must be free of benzyl alcohol).[1]
- N,N-Dimethylaminoethanol (DMAE): Nucleophile.[1][2]
- Solvent: Anhydrous Ethanol or Acetonitrile (promotes polar transition state).[1]

Laboratory Scale Protocol (Self-Validating)

Note: This protocol is designed for high-purity isolation suitable for biological screening.[1]

Step-by-Step Methodology:

- Setup: Equip a 500 mL three-necked round-bottom flask with a reflux condenser, a pressure-equalizing addition funnel, and a nitrogen inlet.
- Charge: Add 0.1 mol (8.91 g) of N,N-Dimethylaminoethanol and 100 mL of anhydrous acetonitrile. Stir to dissolve.
- Addition: Add 0.105 mol (13.3 g) of Benzyl Chloride dropwise over 30 minutes at room temperature. Rationale: Slight excess of BnCl ensures complete consumption of the amine, which is harder to remove.
- Reaction: Heat the mixture to varying reflux (approx. 80°C) for 6–8 hours.
 - Checkpoint: Monitor via TLC (Silica, MeOH:DCM 1:9).[1] The disappearance of the amine spot indicates completion.
- Work-up: Cool the reaction mixture to 0°C in an ice bath. The product should crystallize out.
- Isolation: Filter the white precipitate under vacuum.
- Purification: Recrystallize from hot ethanol/acetone (1:3 ratio).

- Drying: Dry in a vacuum desiccator over P_2O_5 for 24 hours to remove trace moisture.

Synthesis Visualization

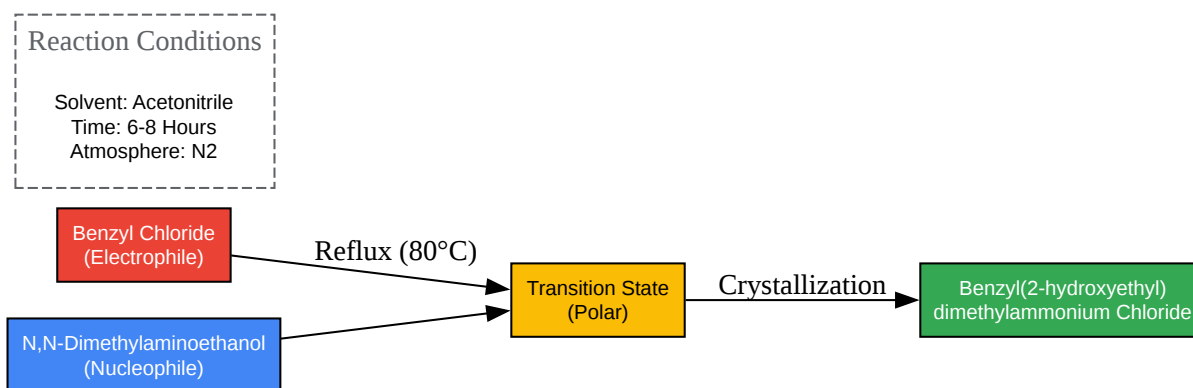

[Click to download full resolution via product page](#)

Figure 1: Menshutkin synthesis pathway for BDHEA Chloride.

Part 4: Functional Mechanisms & Applications

Phase Transfer Catalysis (PTC)

While less lipophilic than tetrabutylammonium salts, BDHEA Chloride serves as a specialized PTC for reactions requiring high water solubility of the catalyst.

- Mechanism: It forms an ion pair with anionic nucleophiles (e.g., CN^- , OH^-) in the aqueous phase, shuttling them into the organic phase or to the interface where reaction occurs.[3]
- Specific Advantage: The hydroxyethyl group can participate in hydrogen bonding, potentially stabilizing specific transition states or improving solubility in polar-aprotic organic solvents.

Electroplating Leveling Agent

In the electronics industry (PCB manufacturing), this compound is a critical additive for Acid Copper Plating.

- Mechanism: The cationic head group adsorbs onto the cathode surface.[4]

- **Leveling Effect:** Adsorption is stronger at high-current-density areas (peaks/protrusions).[1]
This creates a barrier layer that inhibits copper deposition at the peaks, forcing deposition into the valleys (low-current-density areas), resulting in a smooth, bright finish.

Biological & Drug Development Utility[6]

- **Cholinergic Probe:** As a structural analog of Acetylcholine (replacing the acetyl group with a benzyl group), it acts as a muscarinic receptor ligand.
- **Research Use:** Used to study the steric requirements of the choline binding pocket. Research indicates that benzyl-substituted cholines can act as weak agonists or antagonists depending on the specific receptor subtype (M1–M5).[1]
- **Metabolic Stability:** Unlike acetylcholine, the benzyl ether/amine linkage is resistant to rapid hydrolysis by acetylcholinesterase, making it a stable tool for physiological experiments.

Mechanism Visualization

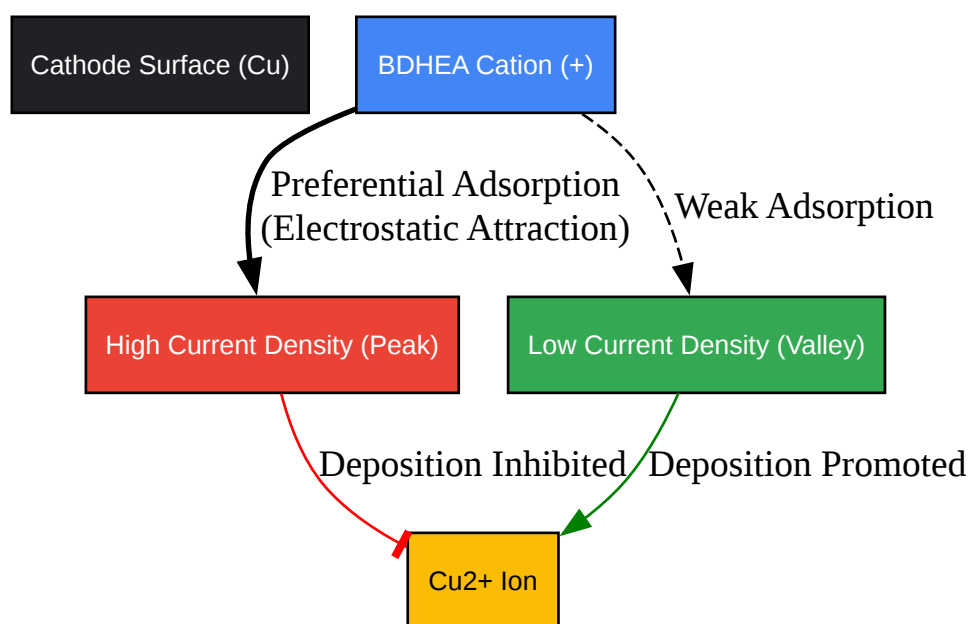

[Click to download full resolution via product page](#)

Figure 2: Mechanism of Action as a Leveling Agent in Copper Electroplating.

Part 5: Safety & Handling (E-E-A-T)[1]

Hazard Classification (GHS):

- Warning
- H315: Causes skin irritation.[1]
- H319: Causes serious eye irritation.[1]
- H335: May cause respiratory irritation.[1]

Handling Protocol:

- PPE: Nitrile gloves, safety goggles, and N95 dust mask are mandatory.
- Hygroscopy: The compound absorbs moisture.[1] Weigh quickly and reseal containers immediately.
- Disposal: As a quaternary ammonium salt, it is toxic to aquatic life.[1] Do not dispose of down the drain. Collect in halogenated organic waste containers.

Part 6: References

- Sigma-Aldrich. Benzyl dimethyl (2-hydroxyethyl) ammonium chloride Product Sheet. Available at: [1]
- PubChem. **Benzyl(2-hydroxyethyl)dimethylammonium chloride** (Compound Summary). National Library of Medicine.[1] Available at: [1]
- MedChemExpress. Quaternary Ammonium Reagents in Life Science. Available at: [1]
- Google Patents. Method for producing alkyl dimethyl benzyl ammonium chlorides (EP1505058A1). Available at: [1]
- ResearchGate. Benzyl-Containing Quaternary Ammonium Salt as a New Leveler for Microvia Copper Electroplating. Available at:

Need Custom Synthesis?

BenchChem offers custom synthesis for rare earth carbides and specific isotopic labeling.

Email: info@benchchem.com or [Request Quote Online](#).

Sources

- [1. Dimethylaminoethyl acrylate benzyl chloride | C14H20ClNO2 | CID 162073 - PubChem \[pubchem.ncbi.nlm.nih.gov\]](#)
- [2. nbinno.com \[nbinno.com\]](#)
- [3. biomedres.us \[biomedres.us\]](#)
- [4. researchgate.net \[researchgate.net\]](#)
- To cite this document: BenchChem. [Technical Monograph: Benzyl(2-hydroxyethyl)dimethylammonium Chloride (CAS 7221-40-1)[1]]. BenchChem, [2026]. [Online PDF]. Available at: [<https://www.benchchem.com/product/b1597992/docs#technical-monograph-benzyl-2-hydroxyethyl-dimethylammonium-chloride-cas-7221-40-1-1>]

Disclaimer & Data Validity:

The information provided in this document is for Research Use Only (RUO) and is strictly not intended for diagnostic or therapeutic procedures. While BenchChem strives to provide accurate protocols, we make no warranties, express or implied, regarding the fitness of this product for every specific experimental setup.

Technical Support: The protocols provided are for reference purposes. Unsure if this reagent suits your experiment?

Need Industrial/Bulk Grade? [Request Custom Synthesis Quote](#)

BenchChem

Our mission is to be the trusted global source of essential and advanced chemicals, empowering scientists and researchers to drive progress in science and industry.

Contact

Address: 3281 E Guasti Rd

Ontario, CA 91761, United States

Phone: (601) 213-4426

Email: info@benchchem.com

[Contact our Ph.D. Support Team for a compatibility check](#)