

# A Comparative Guide to the Structural Validation of 4-Chloro-3-iodotoluene

**Author:** BenchChem Technical Support Team. **Date:** May 2026

## Compound of Interest

Compound Name: 4-Chloro-3-iodotoluene

CAS No.: 2401-22-1

Cat. No.: B1597332

[Get Quote](#)

For researchers, medicinal chemists, and process development professionals, the unambiguous structural confirmation of synthetic intermediates is not merely a procedural step; it is the bedrock of drug discovery and development. An impurity or a misidentified isomer carried forward can jeopardize months of research, compromise patient safety, and lead to significant financial and regulatory setbacks.[1][2] The quality of an Active Pharmaceutical Ingredient (API) is fundamentally determined by the quality of its preceding intermediates.[1]

This guide provides an in-depth, comparative framework for the structural validation of **4-chloro-3-iodotoluene**, a key halogenated intermediate. We will move beyond a simple recitation of data to explain the causal logic behind experimental choices, enabling a robust, self-validating analytical system. Our focus will be on distinguishing the target molecule from its most probable positional isomers, which are the primary source of impurities in a typical synthesis.

## The Synthetic Landscape: Understanding Potential Isomers

The most common route to **4-chloro-3-iodotoluene** is the electrophilic iodination of 4-chlorotoluene. The regiochemical outcome of this reaction is dictated by the directing effects of the substituents on the aromatic ring.

- Methyl Group (-CH<sub>3</sub>): An activating, ortho-, para- director.
- Chloro Group (-Cl): A deactivating, ortho-, para- director.

Given that the para-position to the methyl group is occupied by chlorine, the incoming electrophile (iodine) is directed to the positions ortho to the methyl group (C2 and C6) and ortho to the chloro group (C3 and C5). The directing influences converge primarily on two positions: C3 (ortho to chloro) and, to a lesser extent, C2 (ortho to methyl). This leads to the formation of the desired product alongside a key positional isomer.

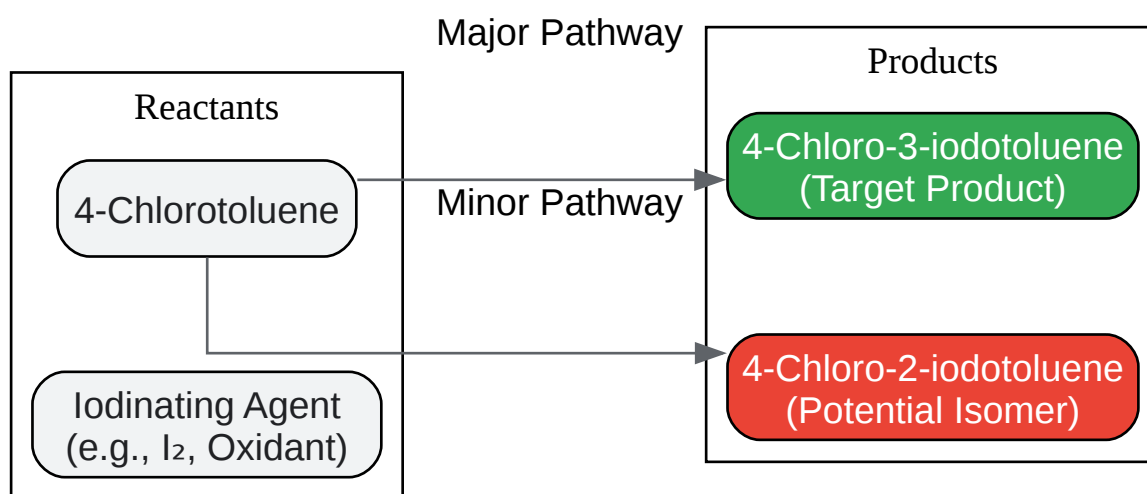

[Click to download full resolution via product page](#)

Caption: Synthetic pathway leading to **4-Chloro-3-iodotoluene** and its primary isomer.

Therefore, any robust validation strategy must be designed not just to confirm the presence of **4-chloro-3-iodotoluene**, but to definitively exclude the presence of 4-chloro-2-iodotoluene.

## The Orthogonal Analytical Workflow

Confidence in structural elucidation is achieved by employing multiple, independent analytical techniques. A weakness in one method (e.g., inability of mass spectrometry to distinguish

isomers) is compensated by the strength of another (e.g., the high structural specificity of NMR). This orthogonal approach forms a self-validating system.

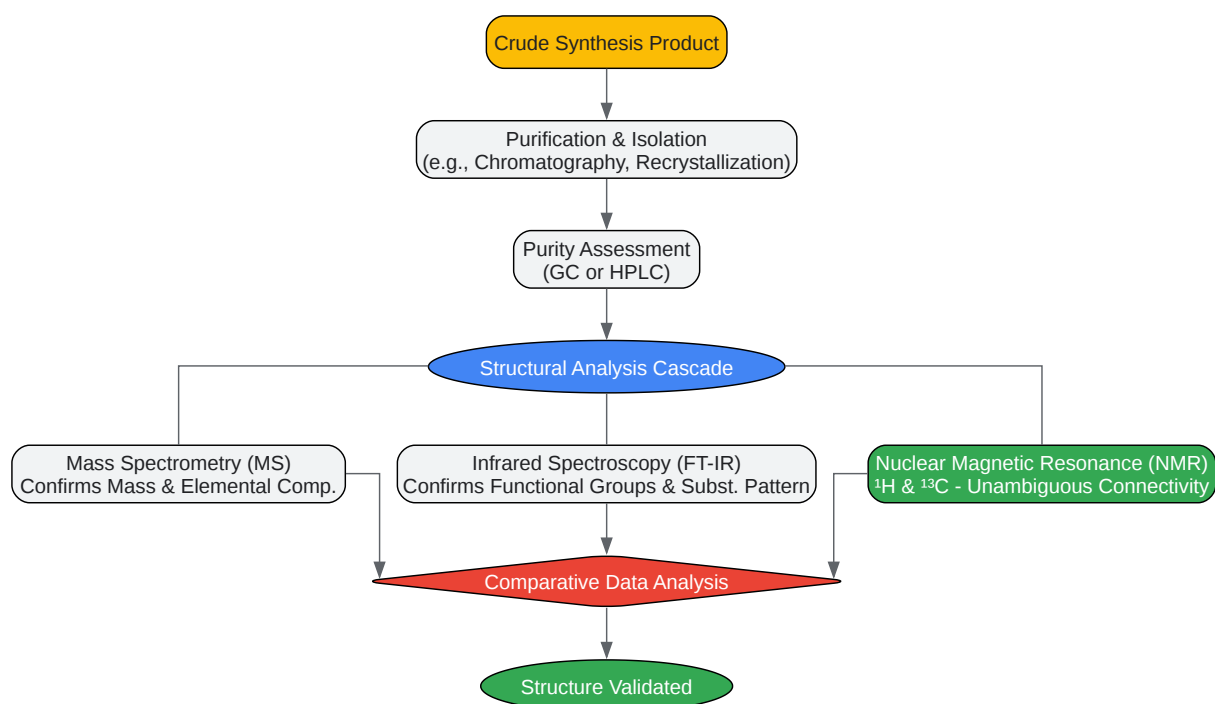

[Click to download full resolution via product page](#)

Caption: Orthogonal workflow for the validation of synthetic products.

# Comparative Spectroscopic Analysis: The Core of Validation

The definitive proof of structure lies in comparing the experimental data against the expected spectral signatures for the target molecule and its likely alternatives.

## Nuclear Magnetic Resonance (NMR) Spectroscopy

NMR is the most powerful tool for distinguishing positional isomers. The chemical environment of each proton and carbon atom is unique, resulting in a distinct spectral fingerprint.

The Causality of NMR Patterns: For substituted benzenes, the key to differentiation is the proton-proton coupling (J-coupling). Protons that are adjacent (ortho) typically show strong coupling (7-9 Hz), while protons separated by four bonds (meta) show weaker coupling (2-3 Hz), and para coupling is often negligible (<1 Hz). This allows us to map the connectivity of the aromatic ring.

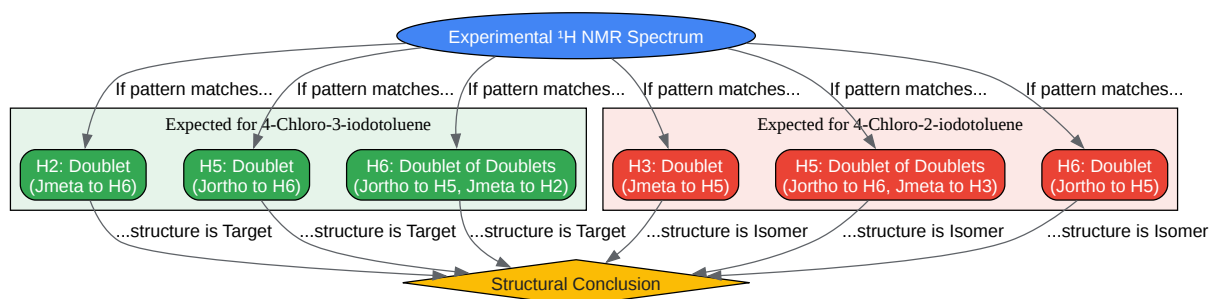

[Click to download full resolution via product page](#)

Caption: Logical flow for distinguishing isomers using  $^1\text{H}$  NMR splitting patterns.

Table 1: Comparative NMR Data

Parameter	4-Chloro-3-iodotoluene (Target)	4-Chloro-2-iodotoluene (Isomer)	Rationale for Difference
<sup>1</sup> H Aromatic Signals	3	3	Both have 3 unique aromatic protons.
<sup>1</sup> H Splitting Pattern	~7.9 ppm (d, J=2 Hz, H2), ~7.4 ppm (d, J=8 Hz, H5), ~7.1 ppm (dd, J=8, 2 Hz, H6)	~7.7 ppm (d, J=2 Hz, H3), ~7.3 ppm (dd, J=8, 2 Hz, H5), ~7.2 ppm (d, J=8 Hz, H6)	The unique arrangement of protons leads to distinct splitting patterns. The d, d, dd vs d, dd, d is the definitive identifier.
<sup>1</sup> H -CH <sub>3</sub> Signal	~2.4 ppm (singlet)	~2.4 ppm (singlet)	The methyl group environment is similar in both.
<sup>13</sup> C Aromatic Signals	6	6	Both have 6 unique aromatic carbons.
<sup>13</sup> C -CH <sub>3</sub> Signal	1	1	Both have one methyl carbon.

Note: Chemical shifts (ppm) are approximate and can vary with solvent and concentration.

## Mass Spectrometry (MS)

While MS is excellent for confirming molecular weight and elemental formula, it is generally poor at distinguishing positional isomers, as they have identical masses and often similar fragmentation patterns.<sup>[3]</sup> However, it serves as a crucial validation checkpoint.

Trustworthiness through Isotopic Patterns: The key feature for halogenated compounds is the isotopic signature. Chlorine has two stable isotopes, <sup>35</sup>Cl and <sup>37</sup>Cl, in an approximate 3:1 ratio. Any compound containing one chlorine atom will exhibit a characteristic pair of peaks in its mass spectrum: the molecular ion peak (M<sup>+</sup>) and an "M+2" peak that is about one-third the intensity of the M<sup>+</sup> peak.<sup>[4]</sup> This provides definitive evidence for the presence of a single chlorine atom.

Table 2: Comparative Mass Spectrometry Data

Parameter	Expected Data for C <sub>7</sub> H <sub>6</sub> ClI	Rationale
Molecular Formula	C <sub>7</sub> H <sub>6</sub> ClI	-
Molecular Weight	252.48 g/mol [5]	-
Nominal Mass (M <sup>+</sup> )	252 (for <sup>35</sup> Cl)	The sum of the integer masses of the most abundant isotopes.
M+2 Peak	254 (for <sup>37</sup> Cl)	Presence confirms one chlorine atom.
M <sup>+</sup> / M+2 Ratio	~3:1	Characteristic isotopic abundance of chlorine.
Key Fragments	m/z 237 ([M-CH <sub>3</sub> ] <sup>+</sup> ), 125 ([M-I] <sup>+</sup> ), 111 ([M-Cl-CH <sub>3</sub> ] <sup>+</sup> )	Fragmentation provides clues to the molecular structure, though likely identical for both isomers.

## Fourier-Transform Infrared (FT-IR) Spectroscopy

FT-IR spectroscopy is used to identify functional groups and can provide strong evidence for the substitution pattern on an aromatic ring.

The Fingerprint of Substitution: While stretches for C-H and C=C bonds confirm the aromatic nature, the most diagnostic region for isomer differentiation is the C-H out-of-plane bending region (900-650 cm<sup>-1</sup>). The number and position of these bands are highly characteristic of the arrangement of substituents on the benzene ring.[6]

Table 3: Comparative FT-IR Data

Vibrational Mode	Expected Wavenumber (cm <sup>-1</sup> )	4-Chloro-3-iodotoluene (1,2,4-trisubstituted)	4-Chloro-2-iodotoluene (1,2,4-trisubstituted)	Rationale for Difference
Aromatic C-H Stretch	3100 - 3000	Present	Present	Confirms aromatic C-H bonds.
Aliphatic C-H Stretch	2950 - 2850	Present	Present	Confirms methyl group C-H bonds.
Aromatic C=C Stretch	1600 - 1450	Multiple bands	Multiple bands	Confirms benzene ring structure.
C-H Out-of-Plane Bend	900 - 800	Strong band ~880-860 cm <sup>-1</sup> and ~820-800 cm <sup>-1</sup>	Strong band ~880-860 cm <sup>-1</sup> and ~820-800 cm <sup>-1</sup>	Both isomers are 1,2,4-trisubstituted, so patterns will be very similar and not a primary differentiation tool in this specific case, but still crucial for confirming the general substitution class.
C-Cl Stretch	~800 - 600	Present	Present	Confirms presence of the C-Cl bond.

## Experimental Protocols

The following are generalized protocols. Specific parameters should be optimized based on the available instrumentation.<sup>[7][8]</sup>

## Protocol 1: Gas Chromatography-Mass Spectrometry (GC-MS)

This method is ideal for assessing purity and obtaining mass spectral data.

- Sample Preparation: Dissolve ~1 mg of the purified product in 1 mL of a suitable solvent (e.g., dichloromethane or ethyl acetate).
- GC Instrumentation:
  - Column: DB-5ms (or equivalent), 30 m x 0.25 mm ID x 0.25  $\mu$ m film.
  - Injector: Splitless, 250°C.
  - Carrier Gas: Helium, constant flow of 1.0 mL/min.
  - Oven Program: Start at 80°C, hold for 2 min, ramp to 280°C at 15°C/min, hold for 5 min.
- MS Instrumentation:
  - Ionization Mode: Electron Ionization (EI) at 70 eV.
  - Mass Range: Scan from m/z 40 to 350.
  - Data Analysis: Integrate peaks to determine purity. Analyze the mass spectrum of the main peak for molecular ion, isotopic pattern, and fragmentation.

## Protocol 2: $^1\text{H}$ and $^{13}\text{C}$ NMR Spectroscopy

- Sample Preparation: Dissolve 5-10 mg of the sample in ~0.7 mL of deuterated chloroform ( $\text{CDCl}_3$ ) or deuterated dimethyl sulfoxide ( $\text{DMSO-d}_6$ ). Add a small amount of tetramethylsilane (TMS) as an internal standard if not already present in the solvent.
- Instrumentation: 400 MHz (or higher) NMR spectrometer.



- $^1\text{H}$  NMR Acquisition:
  - Pulse Program: Standard single pulse (zg30).
  - Spectral Width: ~16 ppm.
  - Acquisition Time: ~4 seconds.
  - Relaxation Delay: 2 seconds.
  - Number of Scans: 16.
- $^{13}\text{C}$  NMR Acquisition:
  - Pulse Program: Proton-decoupled single pulse (zgpg30).
  - Spectral Width: ~240 ppm.
  - Number of Scans: 1024 or more, depending on sample concentration.
- Data Analysis: Process the spectra (Fourier transform, phase correction, baseline correction). Integrate  $^1\text{H}$  signals. Pick peaks and assign chemical shifts and coupling constants. Compare the aromatic region's splitting patterns to the expected patterns for the target and potential isomers.

## Conclusion

The structural validation of **4-chloro-3-iodotoluene** is a clear demonstration of the necessity for a multi-faceted, evidence-based approach in chemical analysis. While mass spectrometry confirms the elemental composition and FT-IR supports the general structure,  $^1\text{H}$  NMR spectroscopy stands as the definitive arbiter for distinguishing it from its primary positional isomer, 4-chloro-2-iodotoluene. The unique splitting pattern of the aromatic protons provides an unambiguous fingerprint of the substituent arrangement. By integrating these orthogonal techniques into a logical workflow, researchers can ensure the structural integrity of their intermediates, thereby safeguarding the foundation of their drug development programs.

## References

- PubChem. 4-Chloro-3-nitrotoluene. National Center for Biotechnology Information. [[Link](#)]
- Cheméo. Chemical Properties of 4-Chloro-3-iodobenzotrifluoride. [[Link](#)]
- 001CHEMICAL. **4-Chloro-3-iodotoluene**. [[Link](#)]
- Klopčič, I., & Dolenc, D. (2011). Regioselective Iodination of Chlorinated Aromatic Compounds Using Silver Salts. *Molecules*, 16(5), 4130–4140. [[Link](#)]
- Tianming Pharmaceuticals. (2026). Analytical Method Development for Intermediate Purity & Impurities. [[Link](#)]
- Tchodimo, F. C. M., & Ermler, W. C. (2023). Theoretical and computational study of benzenium and toluenium isomers. *Frontiers in Chemistry*, 11, 1253599. [[Link](#)]
- Khomenko, B. S., & Gorfinkel, M. I. (1982). Mass spectrometry of halogen-containing organic compounds. *Russian Chemical Reviews*, 51(6), 546-560. [[Link](#)]
- Govindarajan, M., et al. (2011). FT-IR and FT-Raman spectra and vibrational investigation of 4-chloro-2-fluoro toluene using ab initio HF and DFT (B3LYP/B3PW91) calculations. *Spectrochimica Acta Part A: Molecular and Biomolecular Spectroscopy*, 79(5), 1018-1028. [[Link](#)]
- Allied Academies. Analytical method validation: Comprehensive lifecycle approach. *Journal of Pharmaceutical Chemistry & Chemical Science*. [[Link](#)]
- Wang, L., et al. (2016). Chlorination of Toluene to o-Chlorotoluene Catalyzed by Ionic Liquids. *Catalysts*, 6(11), 173. [[Link](#)]
- ALWSCI. (2024). Drug Purity Analysis: A Comprehensive Guide For Biopharmaceutical Professionals. [[Link](#)]
- Abdel-hafez, S. H., et al. (2016). Unexpected synthesis of three components from the reaction of 4-chloro-3-formylcoumarin with hydroxylamine hydrochloride. *Oriental Journal of Chemistry*, 32(1), 379-384. [[Link](#)]
- PrepChem.com. Synthesis of 4-chloro-3-amino-toluene. [[Link](#)]

- Wang, Y., et al. (2020). Development of a proton transfer reaction time-of-flight mass spectrometer with a gas dilution system for rapid analysis of volatile organic compounds. *Atmospheric Measurement Techniques*, 13(1), 1-13. [\[Link\]](#)
- Automated Topology Builder (ATB). 4-Chlorotoluene. [\[Link\]](#)
- Singh, A., et al. (2022). A Benchmark Study of Structural Isomers: Impact of Substitution Position on Acene Cores for Tunable Optoelectronic Properties. *ACS Omega*, 7(35), 31057-31068. [\[Link\]](#)
- BioSpectra, Inc. (2024). Analytical Method Validation Report: Tris Organic Impurities via Liquid Chromatography with UV Detection. [\[Link\]](#)
- NIST. Toluene. NIST Chemistry WebBook. [\[Link\]](#)
- Google Patents. Method of preparing para-chlorotoluene.
- Google Patents. Synthesis method of 4-chloro-3-cresol and system thereof.
- Klopčič, I., & Dolenc, D. (2011). Regioselective iodination of chlorinated aromatic compounds using silver salts. *Tetrahedron Letters*, 52(21), 2731-2734. [\[Link\]](#)
- Agilent Technologies. Purity and Impurity Analysis. [\[Link\]](#)
- PharmOut. Analytical method validation. [\[Link\]](#)
- Organic Chemistry Portal. Iodination. [\[Link\]](#)
- Chemistry LibreTexts. Organic Compounds Containing Halogen Atoms. [\[Link\]](#)
- Cormica. Understanding Impurity Analysis. [\[Link\]](#)
- IISTE. Analytical Purity Method Development and Validation by gas Chromatography of L-valine Methyl Ester Hydrochloride for Production. [\[Link\]](#)
- Fulmer, G. R., et al. (2010). NMR Chemical Shifts of Trace Impurities: Common Laboratory Solvents, Organics, and Gases in Deuterated Solvents Relevant to the Organometallic Chemist. *Organometallics*, 29(9), 2176–2179. [\[Link\]](#)

- Organic Chemistry Portal. Synthesis of iodoarenes. [\[Link\]](#)
- Tchodimo, F. C. M., & Ermler, W. C. (2023). Theoretical and computational study of benzenium and toluenium isomers. *Frontiers in Chemistry*, 11, 1253599. [\[Link\]](#)
- Ramalingam, S., et al. (2009). Fourier transform infrared and FT-Raman spectral analysis and ab initio calculations for 4-chloro-2-methylaniline and 4-chloro-3-methylaniline. *Spectrochimica Acta Part A: Molecular and Biomolecular Spectroscopy*, 74(1), 160-167. [\[Link\]](#)
- Ramalingam, S., et al. (2010). FTIR and FTRaman spectra, assignments, ab initio HF and DFT analysis of 4-nitrotoluene. *Spectrochimica Acta Part A: Molecular and Biomolecular Spectroscopy*, 75(4), 1308-1314. [\[Link\]](#)
- United Nations Office on Drugs and Crime. (2009). Guidance for the Validation of Analytical Methodology and Calibration of Equipment used for Testing of Illicit Drugs in Seized Materials and Biological Specimens. [\[Link\]](#)
- Lucherelli, M. A. A., et al. (2021). Biobased Unsaturated Polyester Resins Modified with Thiophene-2,5-dicarboxylic Acid. *ACS Sustainable Chemistry & Engineering*, 9(1), 223–233. [\[Link\]](#)
- Wikipedia. Octane rating. [\[Link\]](#)
- Fulmer, G. R., et al. (2010). NMR Chemical Shifts of Trace Impurities: Common Laboratory Solvents, Organics, and Gases in Deuterated Solvents Relevant to the Organometallic Chemist. *Organometallics*, 29(9), 2176–2179. [\[Link\]](#)
- The Royal Society of Chemistry. [\[Supporting Information\]](#) L-Proline: an efficient N,O-bidentate ligand for copper-catalyzed aerobic oxidation of primary and secondary benzylic alcohols at room temperature. [\[Link\]](#)

### Need Custom Synthesis?

BenchChem offers custom synthesis for rare earth carbides and specific isotopic labeling.

Email: [info@benchchem.com](mailto:info@benchchem.com) or [Request Quote Online](#).

## Sources

- [1. tianmingpharm.com](https://tianmingpharm.com) [[tianmingpharm.com](https://tianmingpharm.com)]
- [2. Drug Purity Analysis: A Comprehensive Guide For Biopharmaceutical Professionals - Blogs - News](#) [[alwsci.com](https://alwsci.com)]
- [3. researchgate.net](https://researchgate.net) [[researchgate.net](https://researchgate.net)]
- [4. chem.libretexts.org](https://chem.libretexts.org) [[chem.libretexts.org](https://chem.libretexts.org)]
- [5. 001chemical.com](https://001chemical.com) [[001chemical.com](https://001chemical.com)]
- [6. pdf.benchchem.com](https://pdf.benchchem.com) [[pdf.benchchem.com](https://pdf.benchchem.com)]
- [7. pdf.benchchem.com](https://pdf.benchchem.com) [[pdf.benchchem.com](https://pdf.benchchem.com)]
- [8. pharmout.net](https://pharmout.net) [[pharmout.net](https://pharmout.net)]
- To cite this document: BenchChem. [A Comparative Guide to the Structural Validation of 4-Chloro-3-iodotoluene]. BenchChem, [2026]. [Online PDF]. Available at: [<https://www.benchchem.com/product/b1597332/docs#a-comparative-guide-to-the-structural-validation-of-4-chloro-3-iodotoluene>]

---

### Disclaimer & Data Validity:

The information provided in this document is for Research Use Only (RUO) and is strictly not intended for diagnostic or therapeutic procedures. While BenchChem strives to provide accurate protocols, we make no warranties, express or implied, regarding the fitness of this product for every specific experimental setup.

**Technical Support:** The protocols provided are for reference purposes. Unsure if this reagent suits your experiment?

**Need Industrial/Bulk Grade?** [Request Custom Synthesis Quote](#)

# BenchChem

Our mission is to be the trusted global source of essential and advanced chemicals, empowering scientists and researchers to drive progress in science and industry.

## Contact

Address: 3281 E Guasti Rd

Ontario, CA 91761, United States

Phone: (601) 213-4426

Email: [info@benchchem.com](mailto:info@benchchem.com)

[Contact our Ph.D. Support Team for a compatibility check](#)