

Introduction: The Structural Significance of N-Tosylbenzamide

Author: BenchChem Technical Support Team. **Date:** May 2026

Compound of Interest

Compound Name: *N-Tosylbenzamide*

CAS No.: 6971-74-0

Cat. No.: B1596202

[Get Quote](#)

N-Tosylbenzamide is a compound of significant interest in organic synthesis and medicinal chemistry, often serving as a key intermediate or a structural motif in pharmacologically active molecules. Its structure, incorporating a benzamide core and a tosyl group, presents a rich landscape for spectroscopic analysis. Nuclear Magnetic Resonance (NMR) spectroscopy stands as the most powerful technique for the unambiguous structural elucidation and purity assessment of such molecules. An in-depth understanding of its ^1H and ^{13}C NMR spectra is not merely an academic exercise; it is a prerequisite for quality control, reaction monitoring, and the rational design of new chemical entities. This guide provides a comprehensive analysis of the ^1H and ^{13}C NMR spectral data of **N-Tosylbenzamide**, grounded in fundamental principles and supported by field-proven experimental protocols.

Molecular Structure and Atom Numbering for NMR Assignment

To facilitate a clear and unambiguous discussion of the NMR spectral data, a systematic atom numbering scheme for **N-Tosylbenzamide** is essential. The structure consists of a benzoyl group and a tosyl group attached to a central amide nitrogen.

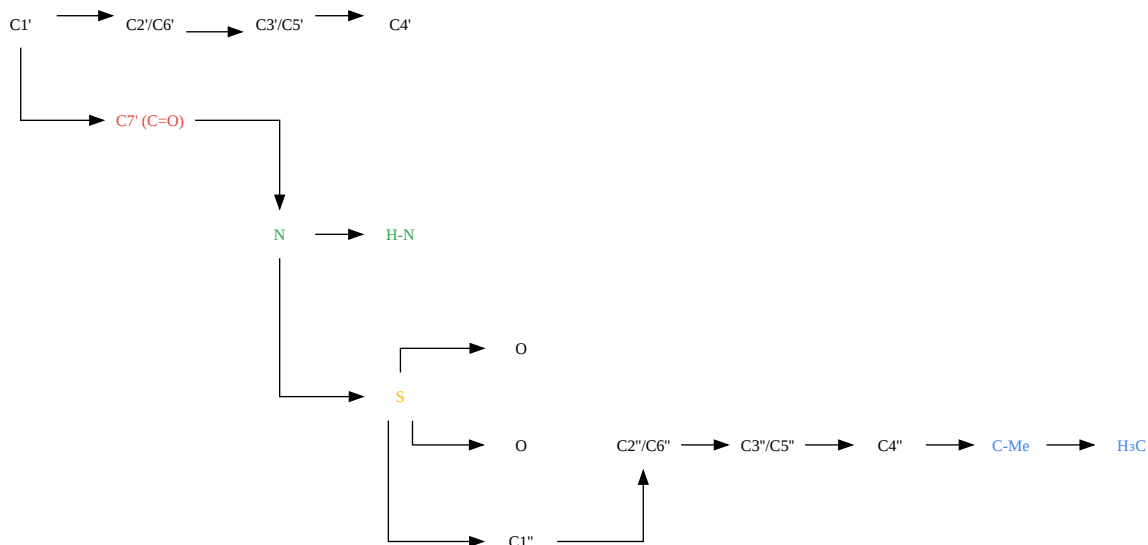

[Click to download full resolution via product page](#)

Figure 1: Molecular structure of **N-Tosylbenzamide** with atom numbering for NMR assignments.

¹H NMR Spectral Analysis

The ¹H NMR spectrum of **N-Tosylbenzamide** provides a wealth of information regarding its proton environment. The chemical shifts are influenced by the electronic effects of the carbonyl and sulfonyl groups, and the coupling patterns reveal the connectivity of the protons. The

spectrum is typically recorded in deuterated chloroform (CDCl_3) or dimethyl sulfoxide (DMSO-d_6). The choice of solvent can significantly impact the chemical shift of the amide proton (N-H) due to differences in hydrogen bonding capabilities.[1][2]

Table 1: Predicted ^1H NMR Spectral Data for **N-Tosylbenzamide** (in DMSO-d_6 , 400 MHz)

Chemical Shift (δ , ppm)	Multiplicity	Integration	Coupling Constant (J, Hz)	Assignment	Rationale
~11.0 - 12.0	Singlet (broad)	1H	-	N-H	The amide proton is highly deshielded due to the electron-withdrawing nature of the adjacent C=O and SO ₂ groups. Its chemical shift is highly dependent on solvent, concentration, and temperature. In DMSO, it forms a strong hydrogen bond, shifting it significantly downfield. ^[1] ^[2]
~7.90	Doublet	2H	~8.0	H-2'/6' (Benzoyl)	These protons are ortho to the electron-withdrawing carbonyl group,

					resulting in significant deshielding.
~7.80	Doublet	2H	~8.2	H-2''/6'' (Tosyl)	Protons ortho to the strongly electron-withdrawing sulfonyl group are deshielded.
~7.65	Triplet	1H	~7.5	H-4' (Benzoyl)	This proton is para to the carbonyl group and appears as a triplet due to coupling with the two H-3'/5' protons.
~7.55	Triplet	2H	~7.8	H-3'/5' (Benzoyl)	These protons are meta to the carbonyl group and are coupled to both H-2'/6' and H-4'.
~7.40	Doublet	2H	~8.0	H-3''/5'' (Tosyl)	Protons meta to the sulfonyl group but ortho to the electron-donating methyl group,

appearing
upfield
relative to H-
2"/6".

~2.40	Singlet	3H	-	CH ₃ (Tosyl)
-------	---------	----	---	-------------------------

The methyl
protons are
attached to
the aromatic
ring and
appear as a
characteristic
singlet in the
aliphatic
region.

¹³C NMR Spectral Analysis

The proton-decoupled ¹³C NMR spectrum complements the ¹H NMR data by providing information on the carbon skeleton of the molecule. The chemical shifts are primarily dictated by the hybridization of the carbon atoms and the electronic effects of neighboring substituents.

Table 2: Predicted ¹³C NMR Spectral Data for **N-Tosylbenzamide** (in DMSO-d₆, 100 MHz)

Chemical Shift (δ , ppm)	Assignment	Rationale
~166.0	C=O (C7')	The carbonyl carbon is highly deshielded and appears at the low-field end of the spectrum, which is characteristic for amide carbonyls.[3]
~144.0	C-4" (Tosyl)	Aromatic quaternary carbon attached to the methyl group.
~138.0	C-1" (Tosyl)	Aromatic quaternary carbon directly attached to the electron-withdrawing sulfonyl group.
~135.0	C-1' (Benzoyl)	Aromatic quaternary carbon attached to the carbonyl group.
~133.0	C-4' (Benzoyl)	Aromatic CH carbon para to the carbonyl group.
~129.5	C-3"/5" (Tosyl)	Aromatic CH carbons on the tosyl ring.
~129.0	C-3'/5' (Benzoyl)	Aromatic CH carbons meta to the carbonyl group.
~128.5	C-2'/6' (Benzoyl)	Aromatic CH carbons ortho to the carbonyl group.
~127.5	C-2"/6" (Tosyl)	Aromatic CH carbons ortho to the sulfonyl group.
~21.0	CH ₃ (Tosyl)	The methyl carbon of the tosyl group appears in the high-field aliphatic region.

Experimental Protocol for High-Quality NMR Data Acquisition

The acquisition of reliable and reproducible NMR data requires a meticulously planned experimental approach. The following protocol is designed to yield high-quality ^1H and ^{13}C NMR spectra for **N-Tosylbenzamide**, ensuring both accuracy and efficiency.

Part 1: Sample Preparation

The quality of the NMR spectrum is fundamentally dependent on the quality of the sample.

- **Compound Purity:** Ensure the **N-Tosylbenzamide** sample is of high purity (>95%), as impurities will introduce extraneous signals that complicate spectral interpretation.
- **Solvent Selection:**
 - **Primary Choice (DMSO- d_6):** Dimethyl sulfoxide- d_6 is an excellent choice due to its high solubilizing power for a wide range of organic compounds and its ability to form strong hydrogen bonds. This results in a sharp, well-resolved signal for the N-H proton, which is often broad or difficult to observe in other solvents.^[4] The residual solvent peak appears at ~2.50 ppm in ^1H NMR and ~39.5 ppm in ^{13}C NMR.
 - **Alternative (CDCl_3):** Deuterated chloroform is another common choice. However, the N-H proton signal may be broader and its chemical shift more concentration-dependent compared to in DMSO- d_6 . The residual solvent peak is at ~7.26 ppm (^1H) and ~77.16 ppm (^{13}C).
- **Procedure:**
 - Accurately weigh 5-10 mg of **N-Tosylbenzamide**.
 - Dissolve the sample in 0.6 - 0.7 mL of the chosen deuterated solvent in a clean, dry vial.
 - For precise chemical shift referencing, add a minimal amount of tetramethylsilane (TMS) as an internal standard (0.00 ppm).
 - Transfer the solution to a 5 mm NMR tube, ensuring the filling height is adequate for the spectrometer's detection coil (typically ~4-5 cm).

Part 2: NMR Spectrometer Setup and Data Acquisition

The following parameters are recommended for a 400 MHz or 500 MHz NMR spectrometer.^[5]
^[6]

¹H NMR Acquisition:

- Pulse Program: Standard single-pulse experiment (e.g., Bruker 'zg30').
- Spectral Width: 0 - 13 ppm.
- Acquisition Time (AQ): 3 - 4 seconds. This ensures sufficient data points across each peak for good resolution.
- Relaxation Delay (D1): 2 - 5 seconds. A longer delay allows for full relaxation of protons, which is crucial for accurate signal integration.
- Number of Scans (NS): 8 - 16 scans for a sample of this concentration.
- Temperature: 298 K (25 °C).

¹³C NMR Acquisition:

- Pulse Program: Proton-decoupled single-pulse experiment (e.g., Bruker 'zgpg30').
- Spectral Width: 0 - 200 ppm.
- Acquisition Time (AQ): 1 - 2 seconds.
- Relaxation Delay (D1): 5 - 10 seconds. Quaternary carbons and other carbons with long relaxation times require a longer delay to be accurately represented. For truly quantitative results, this delay should be at least 5 times the longest T₁ relaxation time.
- Number of Scans (NS): 1024 - 4096 scans, depending on sample concentration and desired signal-to-noise ratio.
- Temperature: 298 K (25 °C).

Part 3: Data Processing

- **Fourier Transformation:** Apply an exponential window function (line broadening of 0.3 Hz for ^1H , 1-2 Hz for ^{13}C) to improve the signal-to-noise ratio, followed by Fourier transformation.
- **Phasing:** Manually phase the spectrum (zero- and first-order corrections) to ensure all peaks have a pure absorption lineshape.
- **Baseline Correction:** Apply a polynomial baseline correction to achieve a flat baseline across the entire spectrum.
- **Referencing:** Calibrate the spectrum by setting the TMS signal to 0.00 ppm. If TMS is not used, reference the residual solvent peak.
- **Peak Picking and Integration:** Identify and label the chemical shifts of all significant peaks. For the ^1H spectrum, integrate the signals to determine the relative number of protons for each resonance.

Workflow for NMR Structural Elucidation

The process from sample to final interpreted spectrum follows a logical and systematic workflow. This self-validating system ensures that the data is reliable and the structural assignment is robust.

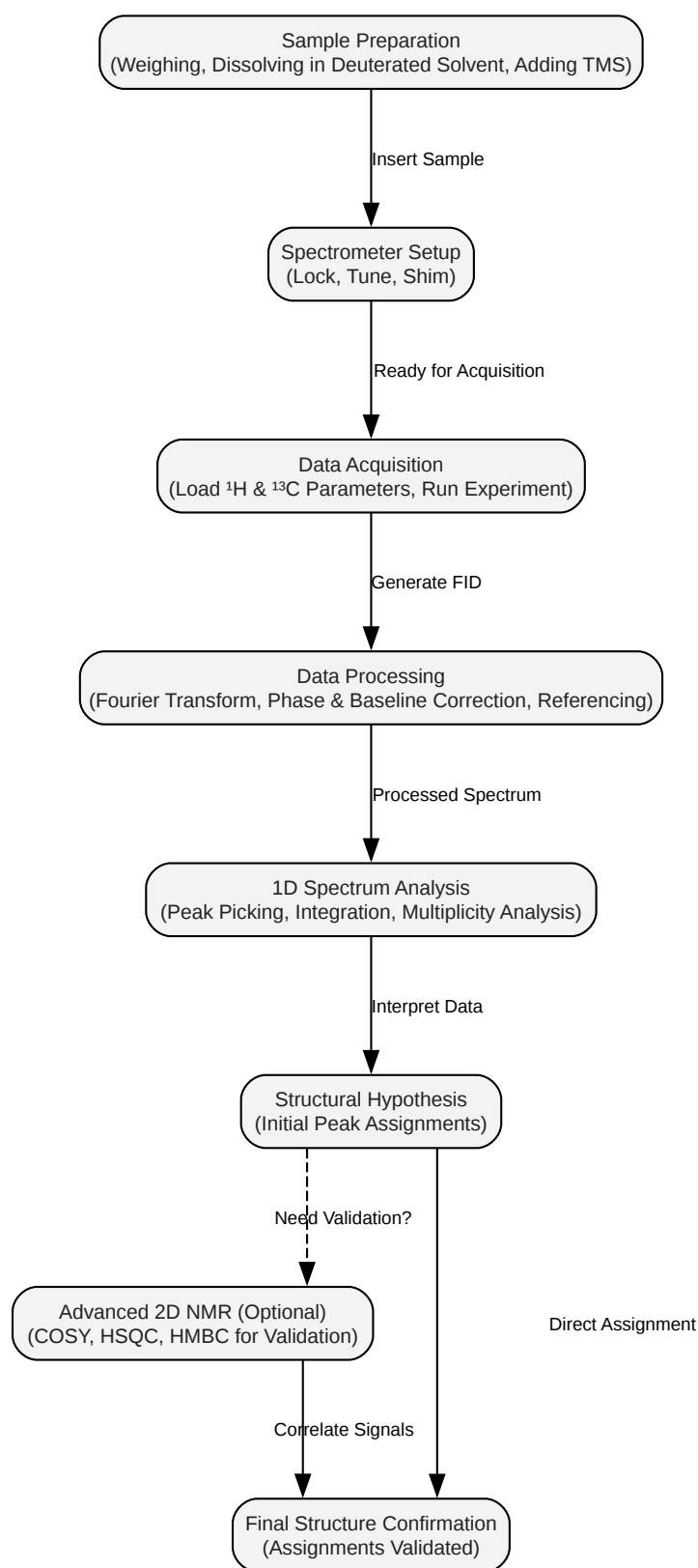

[Click to download full resolution via product page](#)

Need Custom Synthesis?

BenchChem offers custom synthesis for rare earth carbides and specific isotopic labeling.

Email: info@benchchem.com or [Request Quote Online](#).

Sources

- 1. 1H NMR spectra part 31: 1H chemical shifts of amides in DMSO solvent - PubMed [pubmed.ncbi.nlm.nih.gov]
- 2. [researchgate.net](https://www.researchgate.net) [[researchgate.net](https://www.researchgate.net)]
- 3. [rsc.org](https://www.rsc.org) [[rsc.org](https://www.rsc.org)]
- 4. pubs.acs.org [pubs.acs.org]
- 5. [benchchem.com](https://www.benchchem.com) [[benchchem.com](https://www.benchchem.com)]
- 6. books.rsc.org [books.rsc.org]
- To cite this document: BenchChem. [Introduction: The Structural Significance of N-Tosylbenzamide]. BenchChem, [2026]. [Online PDF]. Available at: [<https://www.benchchem.com/product/b1596202/docs#introduction-the-structural-significance-of-n-tosylbenzamide>]

Disclaimer & Data Validity:

The information provided in this document is for Research Use Only (RUO) and is strictly not intended for diagnostic or therapeutic procedures. While BenchChem strives to provide accurate protocols, we make no warranties, express or implied, regarding the fitness of this product for every specific experimental setup.

Technical Support: The protocols provided are for reference purposes. Unsure if this reagent suits your experiment?

Need Industrial/Bulk Grade? [Request Custom Synthesis Quote](#)

BenchChem

Our mission is to be the trusted global source of essential and advanced chemicals, empowering scientists and researchers to drive progress in science and industry.

Contact

Address: 3281 E Guasti Rd

Ontario, CA 91761, United States

Phone: (601) 213-4426

Email: info@benchchem.com

[Contact our Ph.D. Support Team for a compatibility check](#)