

# Introduction: The Significance of Thermochemical Data in Pharmaceutical Development

**Author:** BenchChem Technical Support Team. **Date:** May 2026

## Compound of Interest

Compound Name:	3-Amino-4-methylpicolinic acid
CAS No.:	53636-30-9
Cat. No.:	B1596556

[Get Quote](#)

**3-Amino-4-methylpicolinic acid** (C<sub>7</sub>H<sub>8</sub>N<sub>2</sub>O<sub>2</sub>) belongs to the family of picolinic acid derivatives, which are noted for their roles as ligands and in exhibiting various physiological activities.<sup>[1]</sup> In the context of drug development, the thermochemical profile of an active pharmaceutical ingredient (API) or its intermediates is not merely academic; it is a cornerstone of process safety, formulation stability, and regulatory compliance. Properties such as the enthalpy of formation ( $\Delta_f H^\circ$ ) provide critical insights into the molecule's energetic state, which is essential for assessing thermal hazards and reaction energetics. Heat capacity ( $C_p$ ), entropy ( $S^\circ$ ), and Gibbs free energy ( $\Delta_f G^\circ$ ) are fundamental to predicting reaction spontaneity, equilibrium positions, and the overall stability of the compound under various conditions.<sup>[2][3]</sup>

This guide will first explore the computational methods that provide a powerful, predictive framework for estimating these properties. Subsequently, it will detail the definitive experimental protocols for their empirical measurement, ensuring a self-validating system of characterization.

# Computational Prediction of Thermochemical Properties

In the absence of extensive experimental data, computational chemistry offers a robust and reliable avenue for predicting thermochemical properties. Quantum chemical calculations, particularly methods like the Complete Basis Set (CBS) approaches (e.g., CBS-QB3), have demonstrated high accuracy in estimating enthalpies of formation for organic molecules, often within chemical accuracy ( $\approx 5.0$  kJ/mol).<sup>[4]</sup> These methods provide a critical first look at the molecule's energetic landscape before proceeding with potentially hazardous experimental work.

## Theoretical Workflow for Thermochemical Prediction

The computational determination of thermochemical properties follows a structured, multi-step process. This workflow begins with defining the molecular geometry and proceeds through rigorous calculations to arrive at the final thermodynamic values.

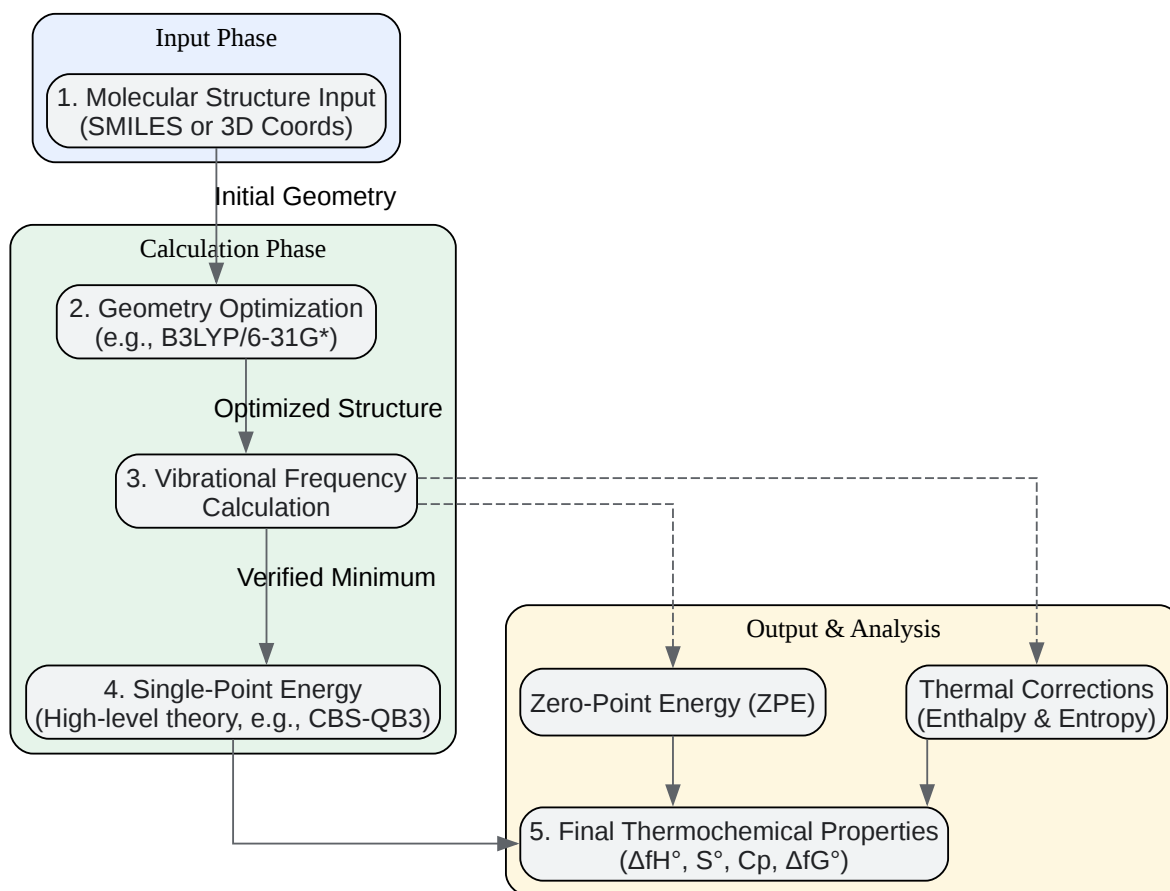

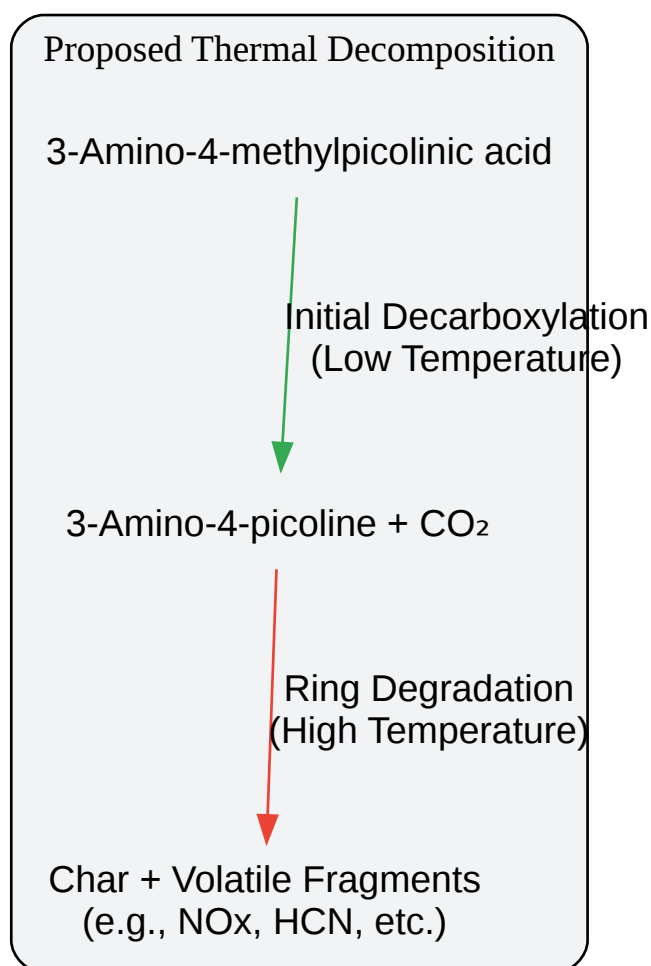

[Click to download full resolution via product page](#)

Caption: A simplified proposed thermal decomposition pathway.

## Conclusion

The thermochemical properties of **3-Amino-4-methylpicolinic acid** are essential for its safe and effective application in research and development. This guide has outlined the standard computational and experimental methodologies necessary for a comprehensive characterization. The predictive power of quantum chemical calculations provides an invaluable initial assessment of the molecule's energetic landscape, guiding subsequent experimental work. Definitive empirical data obtained through techniques like bomb calorimetry, DSC, and TGA provides the ground truth for process modeling, safety analysis, and stability prediction. By integrating these theoretical and experimental approaches, researchers can build a robust

and reliable thermochemical profile for **3-Amino-4-methylpicolinic acid**, enabling its confident use in pharmaceutical and chemical synthesis.

## References

- Rouquerol, J. et al. (n.d.). Thermodynamic Properties of Organic Substances: Experiment, Modeling, and Technological Applications.
- Scirp.org. (n.d.). Experimental Enthalpies of Combustion of Organic Materials and The Correlation with Total Number of Bonds, Their Molecular Surface and Volume Properties.
- National Center for Biotechnology Information. (n.d.). Thermodynamic Properties of Organic Substances: Experiment, Modeling, and Technological Applications - PMC.
- PubMed. (2000). [Structure-physiological activity correlation for picolinic acid derivatives based on quantum chemical data].
- Pedley, J. B., Naylor, R. D., & Kirby, S. P. (1986). Thermochemical data of organic compounds. Second edition. ETDEWEB.
- ResearchGate. (n.d.). Organic Compounds – Physical and Thermochemical Data.
- Asian Journal of Chemistry. (n.d.). Low-Temperature Heat Capacities and Thermal Stability of New Antidepressant [5-Amino-4-(3-indoly)-3-methyl Pyrazole].
- MDPI. (n.d.). Computational Models for Analyzing the Thermodynamic Properties of Linear Triatomic Molecules.
- ResearchGate. (2019). A Thermochemical Computational Study on Hydroxyquinolines and their Azulene Analogues.
- RSC Publishing. (n.d.). Influence of the terminal group on the thermal decomposition reactions of carboxylic acids on copper: nature of the carbonaceous film.
- Revue Roumaine de Chimie. (n.d.). ENTHALPIES OF COMBUSTION AND FORMATION OF ISOMERS OF THE AMINO-BENZOIC ACID.
- ResearchGate. (n.d.). Pyrolysis of Carboxylic Acids.

### Need Custom Synthesis?

BenchChem offers custom synthesis for rare earth carbides and specific isotopic labeling.

Email: [info@benchchem.com](mailto:info@benchchem.com) or [Request Quote Online](#).

## Sources

- [1. \[Structure-physiological activity correlation for picolinic acid derivatives based on quantum chemical data\] - PubMed \[pubmed.ncbi.nlm.nih.gov\]](#)

- [2. tsapps.nist.gov \[tsapps.nist.gov\]](https://tsapps.nist.gov)
- [3. Thermodynamic Properties of Organic Substances: Experiment, Modeling, and Technological Applications - PMC \[pmc.ncbi.nlm.nih.gov\]](https://pubmed.ncbi.nlm.nih.gov/)
- [4. researchgate.net \[researchgate.net\]](https://www.researchgate.net)
- To cite this document: BenchChem. [Introduction: The Significance of Thermochemical Data in Pharmaceutical Development]. BenchChem, [2026]. [Online PDF]. Available at: [\[https://www.benchchem.com/product/b1596556/docs#introduction-the-significance-of-thermochemical-data-in-pharmaceutical-development\]](https://www.benchchem.com/product/b1596556/docs#introduction-the-significance-of-thermochemical-data-in-pharmaceutical-development)

---

### Disclaimer & Data Validity:

The information provided in this document is for Research Use Only (RUO) and is strictly not intended for diagnostic or therapeutic procedures. While BenchChem strives to provide accurate protocols, we make no warranties, express or implied, regarding the fitness of this product for every specific experimental setup.

**Technical Support:** The protocols provided are for reference purposes. Unsure if this reagent suits your experiment?

**Need Industrial/Bulk Grade?** [Request Custom Synthesis Quote](#)

## BenchChem

Our mission is to be the trusted global source of essential and advanced chemicals, empowering scientists and researchers to drive progress in science and industry.

### Contact

Address: 3281 E Guasti Rd  
Ontario, CA 91761, United States  
Phone: (601) 213-4426  
Email: [info@benchchem.com](mailto:info@benchchem.com)

[Contact our Ph.D. Support Team for a compatibility check](#)

