

# An In-depth Technical Guide to the 4-Methoxybenzyl (PMB) Protecting Group

**Author:** BenchChem Technical Support Team. **Date:** May 2026

## Compound of Interest

Compound Name: *N*-(4-Methoxybenzyl)glycine

CAS No.: 20839-78-5

Cat. No.: B1596359

[Get Quote](#)

A Whitepaper for Researchers, Scientists, and Drug Development Professionals

## Core Principles of the 4-Methoxybenzyl Group

The 4-methoxybenzyl (PMB) group, also referred to as the p-methoxybenzyl (MPM) group, is a widely utilized protecting group for hydroxyl, amino, and other nucleophilic functionalities.<sup>[1]</sup> Its prevalence in multi-step synthesis is attributable to a finely tuned balance of stability and selective lability.

The defining feature of the PMB group is the electron-donating methoxy substituent at the para position of the benzyl ring. This electronic perturbation renders the PMB group more susceptible to cleavage under milder oxidative and acidic conditions compared to the unsubstituted benzyl (Bn) group.<sup>[2][3]</sup> This nuanced reactivity allows for its strategic deployment and selective removal in the presence of other protecting groups, a concept known as orthogonality.<sup>[1]</sup>

## Methodologies for Protection

The introduction of a PMB group onto a functional group, most commonly an alcohol, is typically achieved through a Williamson ether synthesis.[1][4] This involves the deprotonation of the alcohol to form a more nucleophilic alkoxide, which then undergoes an SN2 reaction with a 4-methoxybenzyl halide.

## Mechanism of Protection

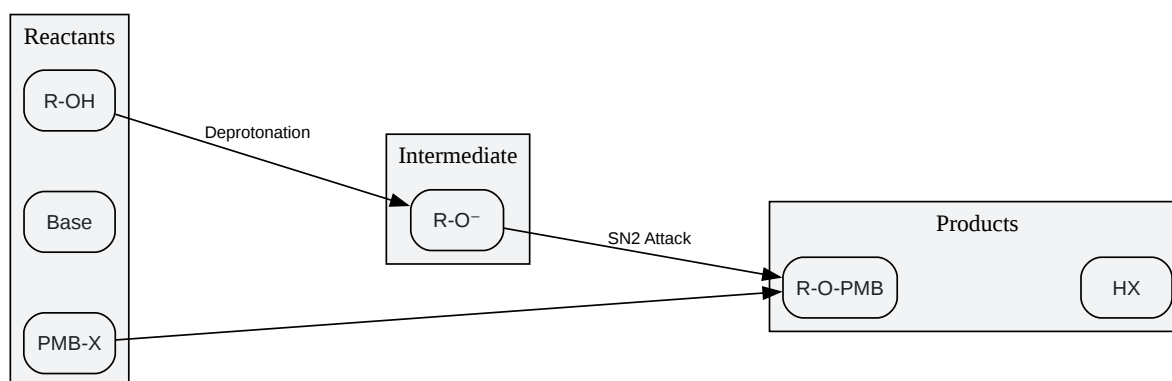

[Click to download full resolution via product page](#)

Caption: Williamson ether synthesis for PMB protection of an alcohol.

## Standard Experimental Protocol: PMB Protection of an Alcohol

- Preparation: To a solution of the alcohol in an anhydrous aprotic solvent (e.g., THF, DMF), add a suitable base (e.g., NaH) at 0 °C.[1]
- Alkoxide Formation: Stir the mixture for 30-60 minutes at 0 °C to facilitate the complete formation of the alkoxide.
- Addition of PMB Halide: Slowly add 4-methoxybenzyl chloride (PMB-Cl) or bromide (PMB-Br) to the reaction mixture.

- Reaction: Allow the reaction to warm to room temperature and stir until completion, as monitored by thin-layer chromatography (TLC).
- Workup and Purification: Quench the reaction with water, extract the product with an organic solvent, wash, dry, and concentrate. Purify the crude product by column chromatography.

Alternative methods for introducing the PMB group, particularly for base-sensitive substrates, involve the use of PMB trichloroacetimidate under acidic conditions.<sup>[1][4]</sup>

## Strategies for Deprotection

The strategic value of the PMB group is most evident in the diverse methods available for its removal, which underpins its orthogonality to other protecting groups.

### Oxidative Cleavage

The most selective and widely used method for PMB ether deprotection is oxidative cleavage.<sup>[1]</sup> Reagents such as 2,3-dichloro-5,6-dicyano-1,4-benzoquinone (DDQ) and ceric ammonium nitrate (CAN) are highly effective.<sup>[5][6][7]</sup> The electron-rich nature of the PMB group facilitates the formation of a charge-transfer complex with the oxidant, initiating the cleavage process.<sup>[2][4]</sup>

#### 3.1.1. Mechanism of DDQ-Mediated Deprotection

The deprotection with DDQ proceeds through a single electron transfer (SET) mechanism.<sup>[1]</sup> This generates a resonance-stabilized radical cation, which is then trapped by water to form a hemiacetal. This intermediate subsequently collapses to yield the deprotected alcohol, 4-methoxybenzaldehyde, and the reduced hydroquinone.<sup>[1][4]</sup>

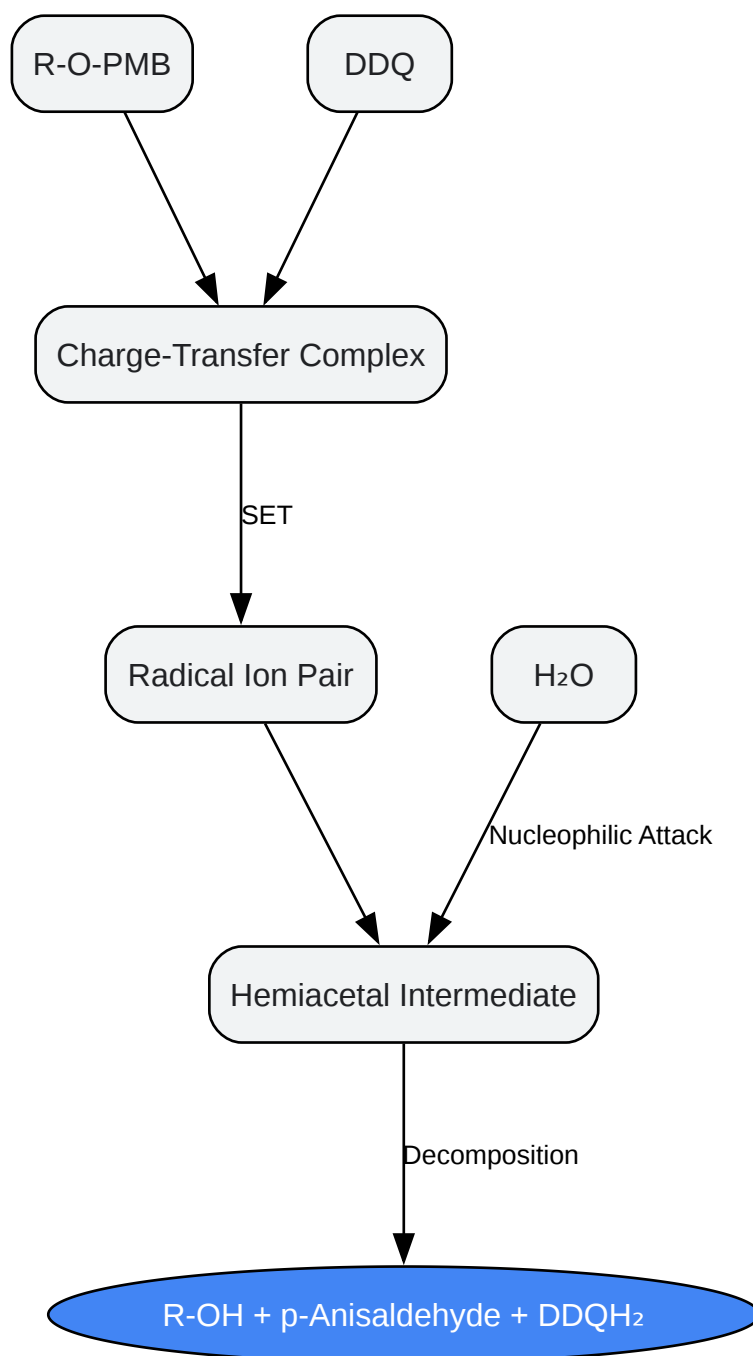

[Click to download full resolution via product page](#)

Caption: Mechanism of oxidative deprotection of a PMB ether using DDQ.

### 3.1.2. Standard Experimental Protocol: DDQ Deprotection

- Setup: Dissolve the PMB-protected substrate in a mixture of CH<sub>2</sub>Cl<sub>2</sub> and water (typically 18:1).[1]

- Reagent Addition: Cool the solution to 0 °C and add DDQ (1.1-1.5 equivalents).[1]
- Reaction: Warm the reaction to room temperature and stir for 1-4 hours, monitoring by TLC. [8]
- Quenching and Extraction: Quench the reaction with a saturated aqueous solution of NaHCO<sub>3</sub>. Extract the aqueous layer with CH<sub>2</sub>Cl<sub>2</sub>.
- Purification: Combine the organic layers, wash with brine, dry over Na<sub>2</sub>SO<sub>4</sub>, filter, and concentrate. Purify the product by column chromatography.

## Acidic Cleavage

The PMB group can also be removed under acidic conditions, although this method is less selective than oxidative cleavage.[9] Trifluoroacetic acid (TFA) is commonly employed for this purpose.[10][11][12] The stability of PMB esters to DDQ allows for orthogonal deprotection strategies.[13]

## Orthogonality and Strategic Implementation

The PMB group's utility is significantly enhanced by its orthogonality with other common protecting groups. This allows for the selective deprotection of the PMB group while leaving others intact, a critical consideration in the synthesis of complex molecules.

Protecting Group	Abbreviation	Stability to DDQ	Stability to Hydrogenolyses	Stability to Strong Acid
Benzyl	Bn	Stable	Labile	Labile
tert-Butyldimethylsilyl	TBDMS	Stable	Stable	Labile
Acetyl	Ac	Stable	Stable	Labile
Methoxymethyl	MOM	Stable	Stable	Labile
Tetrahydropyranyl	THP	Stable	Stable	Labile

This table provides a general overview; specific substrate and reaction conditions may influence stability.

## Comparative Analysis with Other Benzyl-Type Protecting Groups

The reactivity of benzyl-type protecting groups is directly influenced by the electronic nature of the aromatic ring. The presence of electron-donating groups increases their lability towards oxidative and acidic cleavage.

Protecting Group	Relative Rate of Oxidative Cleavage (DDQ)	Relative Rate of Acidic Cleavage (TFA)
2,4-Dimethoxybenzyl (DMB)	Fastest	Fastest
4-Methoxybenzyl (PMB)	Intermediate	Intermediate
Benzyl (Bn)	Slowest (often requires activation)	Slowest

This differential reactivity allows for the sequential deprotection of these groups. For instance, a DMB group can be cleaved in the presence of a PMB group, and a PMB group can be removed while a Bn group remains.<sup>[2]</sup>

## Conclusion

The 4-methoxybenzyl protecting group is a robust and versatile tool in the arsenal of the synthetic organic chemist. Its well-defined reactivity, coupled with a range of selective deprotection methods, provides a high degree of control in complex synthetic sequences. A thorough understanding of its mechanistic nuances and its relationship with other protecting groups is paramount for its effective and strategic implementation in research and development.

## References

- Total Synthesis. (n.d.). PMB Protecting Group: PMB Protection & Deprotection Mechanism. Retrieved from [\[Link\]](#)

- Vanga, R. R., & Fodran, P. (2015). Preparation and Applications of 4-Methoxybenzyl Esters in Organic Synthesis. PMC, 2015, 1-17.
- Garegg, P. J., & Oscarson, S. (1985). Facile Oxidative Cleavage of 4-O-Benzyl Ethers with Dichlorodicyanoquinone in Rhamno and Mannopyranosides.
- Chem-Station. (2014, March 10). p-Methoxybenzyl (PMB) Protective Group. Retrieved from [\[Link\]](#)
- Organic Chemistry. (2021, August 30). DDQ Deprotection Mechanism. YouTube. Retrieved from [\[Link\]](#)
- Reddy, K. K., & Kumar, V. (2011). Mild, selective deprotection of PMB ethers with triflic acid/1,3-dimethoxybenzene. Tetrahedron Letters, 52(41), 5267-5269.
- Chavan, S. P., et al. (2012). A very practical and selective method for PMB protection of alcohols. Tetrahedron Letters, 53(37), 4993-4995.
- Organic Chemistry Portal. (n.d.). Benzyl Ethers - Protecting Groups. Retrieved from [\[Link\]](#)
- Eller, G. A., & Holzer, W. (2004). The 4-Methoxybenzyl (PMB) Function as a Versatile Protecting Group in the Synthesis of N-Unsubstituted Pyrazolones. Heterocycles, 63(11), 2537-2555.
- Organic-Reaction.com. (n.d.). PMB Protection - Common Conditions. Retrieved from [\[Link\]](#)
- Organic Chemistry Portal. (2006, June 12). Protection of N- and O-Functional Groups. Retrieved from [\[Link\]](#)
- Li, X., et al. (2015). Selective Deprotection of Benzyl (Bn) Ethers in the Presence of para-Methoxybenzyl (PMB) Ethers. Organic Letters, 17(21), 5348-5351.
- Reddy, B. V. S., et al. (2019). A Facile, Efficient and Selective Deprotection of P - Methoxy Benzyl Ethers Using Zinc (II) Trifluoromethanesulfonate. Letters in Organic Chemistry, 16(12), 955-958.
- Chavan, S. P., et al. (2012). A Very Practical and Selective Method For PMB Protection of Alcohols. Scribd. Retrieved from [\[Link\]](#)
- Rankin, G. M., et al. (2013). The dimethoxyphenylbenzyl protecting group: an alternative to the p-methoxybenzyl group for protection of carbohydrates. The Journal of Organic Chemistry, 78(13), 6575-6588.

- Sabitha, G., et al. (2000). A Mild and Selective Cleavage of p-Methoxybenzyl Ethers by CBr<sub>4</sub>-MeOH. *Chemistry Letters*, 29(4), 342-343.
- Wright, J. A., & Spencer, N. (2010). Sequential removal of the benzyl-type protecting groups PMB and NAP by oxidative cleavage using CAN and DDQ. *Tetrahedron Letters*, 51(27), 3560-3563.
- ResearchGate. (n.d.). p-Methoxybenzyl ether deprotection by DDQ. Retrieved from [[Link](#)]
- Eller, G. A., & Holzer, W. (2004). The 4-Methoxybenzyl (PMB) Function as a Versatile Protecting Group in the Synthesis of N-Unsubstituted Pyrazolones. u:cris-Portal - University of Vienna. Retrieved from [[Link](#)]
- Rankin, G. M., et al. (2013). The dimethoxyphenylbenzyl protecting group: an alternative to the p-methoxybenzyl group for protection of carbohydrates. SciSpace. Retrieved from [[Link](#)]
- Rankin, G. M., et al. (2013). The Dimethoxyphenylbenzyl Protecting Group: An Alternative to the p-Methoxybenzyl Group for Protection of Carbohydrates. ACS Publications. Retrieved from [[Link](#)]
- Holzer Group. (n.d.). 4-METHOXYBENZYL (PMB) PROTECTED PYRAZOLONES. Retrieved from [[Link](#)]
- Ghorai, P., & Dembélé, Y. A. (2012). Silver(I)-Catalyzed Deprotection of p-Methoxybenzyl Ethers: A Mild and Chemoselective Method. *Organic Letters*, 14(19), 5022-5025.
- Peer-review. (n.d.). A p-methoxybenzyl (PMB) protection/deprotection approach toward the synthesis of 5-phenoxy-4-chloro-N-(aryl/alkyl) thiophene-2-sulfonamides. Pure Help Center. Retrieved from [[Link](#)]

### Need Custom Synthesis?

BenchChem offers custom synthesis for rare earth carbides and specific isotopic labeling.

Email: [info@benchchem.com](mailto:info@benchchem.com) or [Request Quote Online](#).

## Sources

- 1. [total-synthesis.com](https://www.total-synthesis.com) [[total-synthesis.com](https://www.total-synthesis.com)]

- [2. pdf.benchchem.com \[pdf.benchchem.com\]](https://pdf.benchchem.com)
- [3. Benzyl Ethers \[organic-chemistry.org\]](https://organic-chemistry.org)
- [4. p-Methoxybenzyl \(PMB\) Protective Group | Chem-Station Int. Ed. \[en.chem-station.com\]](https://en.chem-station.com)
- [5. Facile Oxidative Cleavage of 4-O-Benzyl Ethers with Dichlorodicyanoquinone in Rhamno and Mannopyranosides - PMC \[pmc.ncbi.nlm.nih.gov\]](https://pubmed.ncbi.nlm.nih.gov)
- [6. academic.oup.com \[academic.oup.com\]](https://academic.oup.com)
- [7. researchgate.net \[researchgate.net\]](https://researchgate.net)
- [8. pdf.benchchem.com \[pdf.benchchem.com\]](https://pdf.benchchem.com)
- [9. Protecting groups in organic synthesis - protection and deprotection of alcoholic hydroxyl groups \(I\) \[en.highfine.com\]](https://en.highfine.com)
- [10. researchgate.net \[researchgate.net\]](https://researchgate.net)
- [11. PMB Protection - Common Conditions \[commonorganicchemistry.com\]](https://commonorganicchemistry.com)
- [12. ucrisportal.univie.ac.at \[ucrisportal.univie.ac.at\]](https://ucrisportal.univie.ac.at)
- [13. Preparation and Applications of 4-Methoxybenzyl Esters in Organic Synthesis - PMC \[pmc.ncbi.nlm.nih.gov\]](https://pubmed.ncbi.nlm.nih.gov)
- To cite this document: BenchChem. [An In-depth Technical Guide to the 4-Methoxybenzyl (PMB) Protecting Group]. BenchChem, [2026]. [Online PDF]. Available at: [\[https://www.benchchem.com/product/b1596359/docs#an-in-depth-technical-guide-to-the-4-methoxybenzyl-pmb-protecting-group\]](https://www.benchchem.com/product/b1596359/docs#an-in-depth-technical-guide-to-the-4-methoxybenzyl-pmb-protecting-group)

---

### Disclaimer & Data Validity:

The information provided in this document is for Research Use Only (RUO) and is strictly not intended for diagnostic or therapeutic procedures. While BenchChem strives to provide accurate protocols, we make no warranties, express or implied, regarding the fitness of this product for every specific experimental setup.

**Technical Support:** The protocols provided are for reference purposes. Unsure if this reagent suits your experiment?

**Need Industrial/Bulk Grade?** [Request Custom Synthesis Quote](#)

# BenchChem

Our mission is to be the trusted global source of essential and advanced chemicals, empowering scientists and researchers to drive progress in science and industry.

## Contact

Address: 3281 E Guasti Rd

Ontario, CA 91761, United States

Phone: (601) 213-4426

Email: [info@benchchem.com](mailto:info@benchchem.com)

[Contact our Ph.D. Support Team for a compatibility check](#)