

# Technical Support Center: Scaling Up 6-Chloro-N-ethylnicotinamide Synthesis

**Author:** BenchChem Technical Support Team. **Date:** May 2026

## Compound of Interest

Compound Name: 6-Chloro-N-ethylnicotinamide

CAS No.: 54864-84-5

Cat. No.: B1595874

[Get Quote](#)

Department: Process Chemistry & Scale-Up Support Subject: Technical Guide for Transitioning from Milligram to Kilogram Scale Reference ID: TSC-6CNE-2024

## Introduction

Welcome to the Technical Support Center. This guide addresses the scale-up challenges of synthesizing **6-Chloro-N-ethylnicotinamide** (CAS: 54864-84-5). While the synthesis appears straightforward on paper, scaling this reaction introduces thermodynamic and kinetic risks that are often invisible on the milligram scale.

This guide focuses on the Acid Chloride Route (via Thionyl Chloride), as it is the most cost-effective method for multi-kilogram production compared to peptide coupling agents (EDC/HATU).

## Module 1: Reaction Kinetics & Critical Pathways

### The Core Challenge: Competitive Nucleophilic Attack

On a scale-up, heat transfer becomes rate-limiting. The primary failure mode in this synthesis is the loss of the chlorine atom at the C6 position.

- Desired Path: Ethylamine attacks the carbonyl carbon (Acyl Substitution).
- Undesired Path (SnAr): Ethylamine attacks the C6 carbon of the pyridine ring (Nucleophilic Aromatic Substitution), displacing the chlorine. This is driven by excess heat and high local concentration of the amine.

## Visualizing the Pathway

The following diagram illustrates the kinetic competition you must manage.

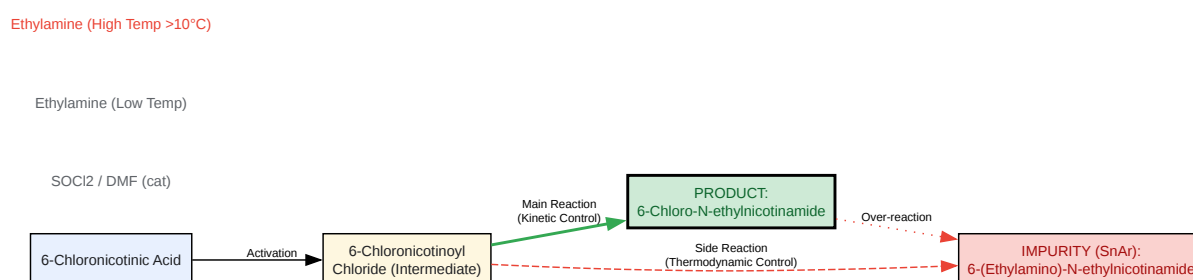

[Click to download full resolution via product page](#)

Figure 1: Reaction pathway showing the competition between the desired acylation and the undesired SnAr displacement of the chlorine atom.

## Module 2: 1.0 Mole Scale-Up Protocol

Scale: 1.0 Mol (~157g Starting Material) Objective: Produce >95% purity white solid without chromatography.

### Step 1: Activation (Acid Chloride Formation)

- Reagents: 6-Chloronicotinic acid (157.6 g, 1.0 mol), Thionyl Chloride (238 g, 2.0 mol), Toluene (800 mL), DMF (1 mL, catalyst).
- Protocol:
  - Suspend 6-Chloronicotinic acid in Toluene under .
  - Add DMF catalyst.
  - Heat to 50°C.
  - Add Thionyl Chloride dropwise over 1 hour. Note: Vigorous off-gassing of SO<sub>2</sub> and HCl will occur. Ensure scrubber is active.
  - Reflux at 80-90°C for 2-3 hours until solution is clear.
  - Critical Step: Distill off excess Thionyl Chloride and Toluene under reduced pressure to yield the crude acid chloride as a solid/oil. Re-dissolve in fresh dry THF (500 mL) or Toluene.

## Step 2: Amidation (The Danger Zone)

- Reagents: Crude Acid Chloride (from Step 1), Ethylamine (2.0M in THF or 70% aq, 1.1 eq), Triethylamine (1.2 eq) OR Excess Ethylamine (2.5 eq total).
- Protocol:
  - Cool the Acid Chloride solution to -10°C to 0°C.
  - Prepare a solution of Ethylamine and Base in THF.
  - Slow Addition: Add the amine solution to the acid chloride over 2 hours.
  - Monitor Internal Temp: Do NOT let the internal temperature rise above 5°C.
    - Why? Above 10°C, the S<sub>N</sub>Ar reaction rate increases significantly, leading to the yellow impurity.

- Stir at 0°C for 1 hour, then allow to warm to room temperature (20°C).

## Step 3: Work-up & Purification

- Quench: Add water (500 mL) to dissolve salts.
- Extraction: Extract with Ethyl Acetate (if Toluene was not used).
- Wash: Wash organic layer with 1M NaHCO<sub>3</sub> (removes unreacted acid) and Brine.
- Crystallization:
  - Concentrate organics.
  - Solvent System: Heat in Heptane/Ethyl Acetate (4:1) or Ethanol/Water.
  - Cool slowly to 4°C. Filter white needles.

## Module 3: Troubleshooting Guide (Q&A)

### Category A: Impurity Profile

Q1: My product has a persistent yellow color. What is it?

- Diagnosis: This is the tell-tale sign of the SnAr side product (6-(ethylamino)-N-ethylnicotinamide). The replacement of the Chlorine with an amine extends the conjugation of the pyridine ring, shifting absorption into the visible (yellow) spectrum.
- Root Cause: The amidation reaction temperature spiked >10°C, or local hot-spots occurred during amine addition.
- Fix: You cannot easily remove this by recrystallization as the solubility profile is similar. You must control the temperature strictly during addition (<5°C).

Q2: I see a peak at mass [M+1] = 158 in LCMS. What is this?

- Diagnosis: This is 6-Chloronicotinic acid (Starting Material).

- Root Cause: Incomplete conversion to acid chloride OR moisture ingress during the amidation step which hydrolyzed the acid chloride back to the acid.
- Fix: Ensure Thionyl Chloride step goes to completion (clear solution). Use anhydrous solvents for the amidation step.[1]

## Category B: Process Engineering

Q3: The reaction mixture solidified/turned into a thick paste during amine addition.

- Diagnosis: Precipitation of Triethylamine Hydrochloride (or Ethylamine Hydrochloride) salts.
- Risk: This stops stirring, ruins heat transfer, and creates "hot spots" where impurities form.
- Fix: Increase solvent volume (THF or Toluene). Use an overhead mechanical stirrer (not a magnetic stir bar) for any scale >50g.

Q4: Can I use aqueous Ethylamine (70%) instead of THF solution?

- Answer: Yes, but it is a biphasic reaction (Schotten-Baumann conditions).
- Adjustment: You must use a vigorous stir rate and keep the temperature even lower (-5°C) because the water competes with the amine for the acid chloride (hydrolysis risk). The amine is usually a better nucleophile than water, but temperature control is vital.

## Module 4: Safety & Engineering Controls

When scaling to >100g, the off-gassing of Thionyl Chloride is non-trivial.

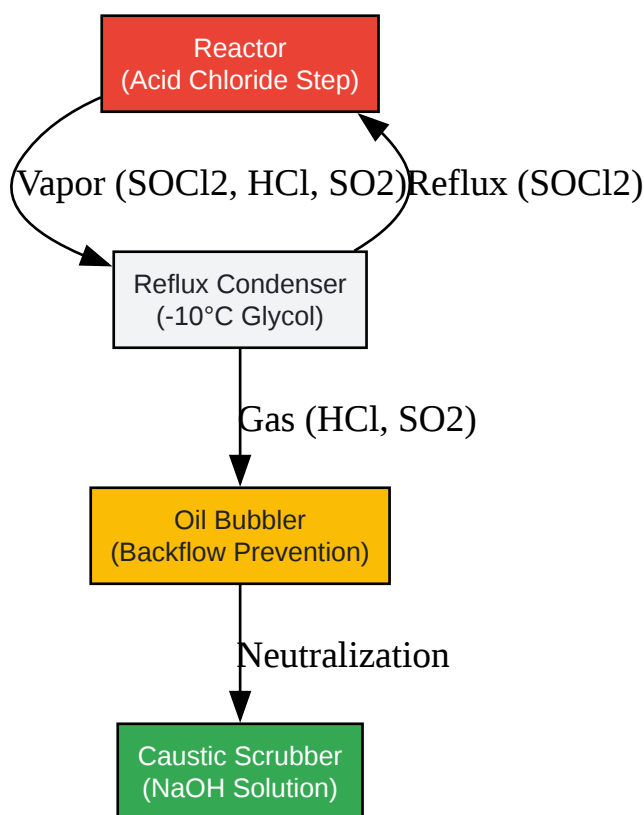

[Click to download full resolution via product page](#)

Figure 2: Mandatory scrubber setup for Thionyl Chloride activation step to prevent release of toxic HCl and SO<sub>2</sub> gas.

## Data Summary: Reagent Selection

Reagent	Cost	Atom Economy	Scale-Up Suitability	Risk Note
Thionyl Chloride	Low	High	Excellent	Corrosive gas evolution.
Oxalyl Chloride	Medium	Medium	Good	Generates CO (toxic).
HATU/EDC	High	Low	Poor	High cost; difficult byproduct removal.[2]

## References

- BenchChem.Application Notes and Protocols for the Synthesis of Amides using 5-Bromo-6-chloronicotinoyl chloride. (Protocol adapted for 6-Chloro analog).[3]
- PrepChem.Synthesis of 6-chloronicotinoyl chloride. (Standard Acid Chloride activation parameters).
- National Institutes of Health (NIH).Improved scale-up synthesis and purification of clinical asthma candidate MIDD0301. (Crystallization solvents for nicotinamides).[4]
- Master Organic Chemistry.Nucleophilic Aromatic Substitution (SnAr). (Mechanistic grounding for impurity formation).
- Fisher Scientific.Safety Data Sheet: Thionyl Chloride.

### Need Custom Synthesis?

BenchChem offers custom synthesis for rare earth carbides and specific isotopic labeling.

Email: [info@benchchem.com](mailto:info@benchchem.com) or [Request Quote Online](#).

## Sources

- [1. pdf.benchchem.com \[pdf.benchchem.com\]](https://pdf.benchchem.com)
- [2. CN101851194B - Preparation method of nicotinamide - Google Patents \[patents.google.com\]](https://patents.google.com/patents/CN101851194B)
- [3. pdf.benchchem.com \[pdf.benchchem.com\]](https://pdf.benchchem.com)
- [4. par.nsf.gov \[par.nsf.gov\]](https://par.nsf.gov)
- To cite this document: BenchChem. [Technical Support Center: Scaling Up 6-Chloro-N-ethylnicotinamide Synthesis]. BenchChem, [2026]. [Online PDF]. Available at: [\[https://www.benchchem.com/product/b1595874/docs#technical-support-center-scaling-up-6-chloro-n-ethylnicotinamide-synthesis\]](https://www.benchchem.com/product/b1595874/docs#technical-support-center-scaling-up-6-chloro-n-ethylnicotinamide-synthesis)

---

### Disclaimer & Data Validity:

The information provided in this document is for Research Use Only (RUO) and is strictly not intended for diagnostic or therapeutic procedures. While BenchChem strives to provide accurate protocols, we make no warranties, express or implied, regarding the fitness of this product for every specific experimental setup.

**Technical Support:** The protocols provided are for reference purposes. Unsure if this reagent suits your experiment?

**Need Industrial/Bulk Grade?** [Request Custom Synthesis Quote](#)

## BenchChem

Our mission is to be the trusted global source of essential and advanced chemicals, empowering scientists and researchers to drive progress in science and industry.

### Contact

Address: 3281 E Guasti Rd  
Ontario, CA 91761, United States  
Phone: (601) 213-4426  
Email: [info@benchchem.com](mailto:info@benchchem.com)

[Contact our Ph.D. Support Team for a compatibility check](#)