

# Technical Support Center: Purification of Z-Ala-Ala-NH<sub>2</sub>

**Author:** BenchChem Technical Support Team. **Date:** May 2026

## Compound of Interest

Compound Name: Z-ALA-ALA-NH<sub>2</sub>

CAS No.: 50444-54-7

Cat. No.: B1595228

[Get Quote](#)

Subject: Troubleshooting & Optimization Guide for the Purification of **Z-Ala-Ala-NH<sub>2</sub>** (Carbobenzoxy-L-alanyl-L-alanine amide) Ticket ID: TECH-ZAA-001 Support Level: Senior Application Scientist

## Introduction

Welcome to the Technical Support Center. You are likely synthesizing **Z-Ala-Ala-NH<sub>2</sub>**, a common substrate for elastase and a key intermediate in peptide chemistry. This molecule presents a specific purification profile: the Z-group (benzyloxycarbonyl) renders it lipophilic, while the C-terminal amide (-NH<sub>2</sub>) makes it neutral, distinguishing it from free-acid peptides.

This guide addresses the three most common failure points in its purification:

- Incomplete removal of coupling reagents (Urea contamination).
- Co-elution of starting materials (Z-Ala-OH or Ala-NH<sub>2</sub>).
- "Oiling out" during recrystallization.

## Module 1: The Standard Workup (The First Line of Defense)

Before attempting chromatography, you must maximize purity via Liquid-Liquid Extraction (LLE). Because **Z-Ala-Ala-NH<sub>2</sub>** is a neutral amide, we can aggressively wash away acidic and basic impurities.

### The Logic of Extraction

- Target (**Z-Ala-Ala-NH<sub>2</sub>**): Neutral. Stays in the Organic Phase (Ethyl Acetate or DCM).
- Impurity A (Ala-NH<sub>2</sub>): Basic. Moves to Aqueous Phase at low pH.
- Impurity B (Z-Ala-OH): Acidic. Moves to Aqueous Phase at high pH.

### Workflow Diagram

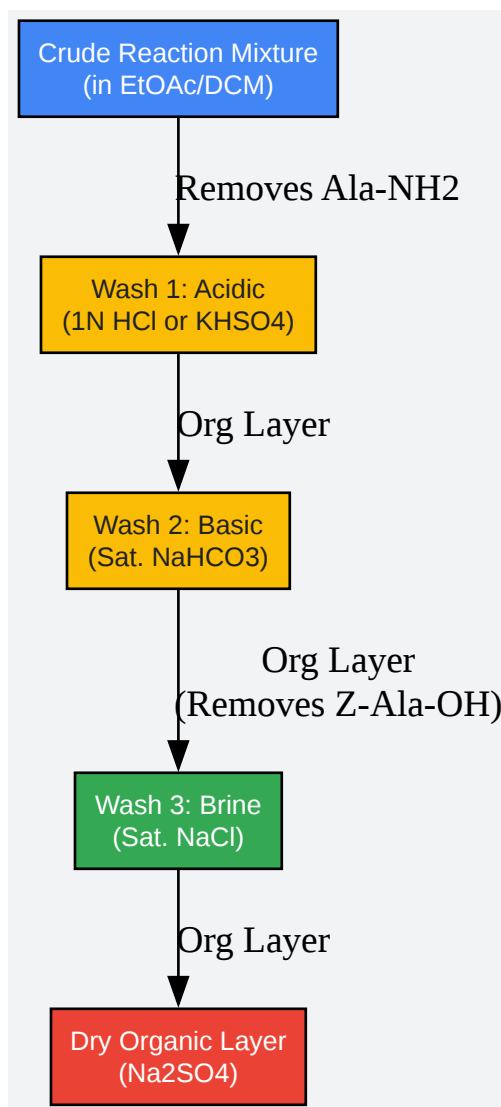

[Click to download full resolution via product page](#)

Figure 1: Liquid-Liquid Extraction logic for neutral peptide amides.

## Protocol: Optimized Wash Cycle

Solvent System: Ethyl Acetate (EtOAc) is preferred over Dichloromethane (DCM) as it separates better from water and is less likely to form emulsions with peptide amides.

- Dilution: Dilute the reaction mixture with EtOAc (approx. 10x volume of crude).
- Acid Wash (Removes Amine): Wash 2x with 1N HCl or 5% KHSO<sub>4</sub>.
  - Why? Protonates unreacted H-Ala-NH<sub>2</sub>, forcing it into the water layer.

- Base Wash (Removes Acid): Wash 2x with Saturated NaHCO<sub>3</sub>.
  - Why? Deprotonates unreacted Z-Ala-OH, forming the water-soluble sodium salt.
- Neutralization: Wash 1x with Brine (Saturated NaCl) to remove trapped water.
- Drying: Dry over anhydrous Na<sub>2</sub>SO<sub>4</sub> and concentrate in vacuo.

## Module 2: Troubleshooting Recrystallization

If your product is 85-90% pure after workup, recrystallization is superior to column chromatography for scalability.

### Common Issue: "Oiling Out"

Z-protected peptides often separate as an oil rather than a crystal. This happens when the compound precipitates too fast or the solvent polarity is slightly off.

### Recommended Solvent Systems

Solvent System	Ratio (v/v)	Procedure	Success Rate
EtOAc / Hexane	1:1 to 1:4	Dissolve in min. hot EtOAc. Add warm Hexane until cloudy. Cool slowly.	High (Standard)
Ethanol / Water	9:1 to 1:1	Dissolve in hot EtOH. Add water dropwise.	Medium (Risk of oiling)
MeOH / Ether	Solvent/Anti-solvent	Dissolve in MeOH. Vigorously stir while pouring into excess cold Ether.	High (For precipitation only)

### Protocol: The "Scratch and Seed" Technique

If you get an oil:

- Re-heat the mixture until the oil dissolves.

- Add a slightly smaller amount of the anti-solvent (e.g., Hexane) than before.[1]
- Let it cool to room temperature undisturbed.
- Crucial Step: If oil forms, scratch the inner wall of the glass flask with a metal spatula at the interface of the oil and solvent. The microscopic glass shards act as nucleation sites.

## Module 3: Chromatographic Separation

If high purity (>98%) is required for biological assays (e.g., Elastase kinetics), you must use chromatography to remove stereoisomers (LL vs. DL) and urea byproducts.

### Decision Matrix: Flash vs. HPLC

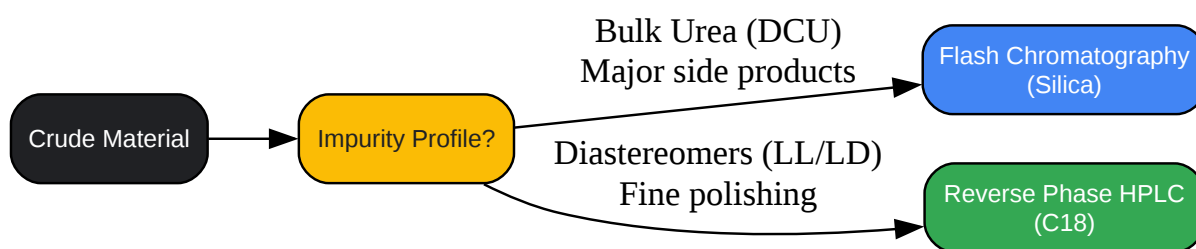

[Click to download full resolution via product page](#)

Figure 2: Choosing the right chromatographic tool.

### Method A: Flash Chromatography (Silica Gel)

- Stationary Phase: Silica Gel (40-63  $\mu\text{m}$ ).
- Mobile Phase: Chloroform ( $\text{CHCl}_3$ ) : Methanol (MeOH) (Gradient 98:2 to 90:10).
  - Technical Insight: Avoid Hexane/EtOAc if you have DCU (Dicyclohexylurea) contamination.[2] DCU is slightly soluble in EtOAc and will smear across your product fractions.  $\text{CHCl}_3$  dissolves DCU better, allowing it to elute, or separates it distinctly.[2]

### Method B: Reverse-Phase HPLC (C18)[3]

- Column: C18 (e.g., Agilent Zorbax or Phenomenex Jupiter).

- Buffer A: Water + 0.1% TFA.
- Buffer B: Acetonitrile (ACN) + 0.1% TFA.
- Gradient: 20% B to 80% B over 30 minutes.
  - Detection: 214 nm (Amide bond) and 254 nm (Z-group aromatic ring).

## Module 4: Frequently Asked Questions (FAQ)

### Q1: I used DCC as a coupling reagent, and I can't get rid of the white solid (DCU).

Answer: Dicyclohexylurea (DCU) is the bane of peptide synthesis.

- Filtration: Cool the reaction mixture to 0°C for 1 hour. DCU precipitates in the cold. Filter through Celite.
- Chemical Switch: In the future, use EDC.HCl (1-Ethyl-3-(3-dimethylaminopropyl)carbodiimide). The urea byproduct of EDC is water-soluble and is completely removed during the acid wash (Module 1).
- Trituration: If the solid persists in your final product, triturate (wash) the solid product with cold ether. **Z-Ala-Ala-NH<sub>2</sub>** is insoluble in ether, but residual urea/impurities may wash away.

### Q2: My product yield is good, but the optical rotation is off. Why?

Answer: You likely have Racemization.

- Cause: Activation of the carboxyl group (Z-Ala-OH) can lead to oxazolone formation, which racemizes the alpha-carbon.
- Solution: Always use an additive like HOBt (Hydroxybenzotriazole) or HOAt alongside your carbodiimide (DCC/EDC). These suppress racemization.
- Detection: Run C18 HPLC.<sup>[3]</sup> The DL-diastereomer usually elutes slightly earlier or later than the LL-isomer.

## Q3: Can I convert Z-Ala-Ala-OMe to Z-Ala-Ala-NH<sub>2</sub> directly?

Answer: Yes. If you synthesized the ester first, you can convert it to the amide using Methanolic Ammonia (saturated ammonia gas in methanol).

- Warning: This reaction is slow. Stir at room temperature for 1-2 days. Monitor by TLC.[4] This avoids the coupling of Ala-NH<sub>2</sub> entirely.[5]

## References

- BenchChem. (2025).[6] Navigating Byproduct Removal in Peptide Synthesis: A Comparative Guide to 1,3-Diisopropylurea (DIU) and Dicyclohexylurea (DCU). Retrieved from
- ResearchGate. (2013). How can I remove DCU (dicyclohexyl urea) byproduct formed during esterification reaction? Retrieved from
- University of Rochester. (n.d.). Purification: How To - Recrystallization Tips and Tricks.[1] Retrieved from
- Peptide.com. (n.d.). Practical Synthesis Guide to Solid Phase Peptide Chemistry. Retrieved from
- Asian Journal of Chemistry. (2013). Preparation and Characterization of a Novel Ala-Gln Dipeptide-Zn<sup>2+</sup> Complex. (Relevant for solubility/precipitation behavior of Ala-dipeptides). Retrieved from

### Need Custom Synthesis?

BenchChem offers custom synthesis for rare earth carbides and specific isotopic labeling.

Email: [info@benchchem.com](mailto:info@benchchem.com) or [Request Quote Online](#).

## Sources

- [1. Purification \[chem.rochester.edu\]](#)
- [2. researchgate.net \[researchgate.net\]](#)

- [3. researchgate.net \[researchgate.net\]](#)
- [4. researchgate.net \[researchgate.net\]](#)
- [5. researchgate.net \[researchgate.net\]](#)
- [6. pdf.benchchem.com \[pdf.benchchem.com\]](#)
- To cite this document: BenchChem. [Technical Support Center: Purification of Z-Ala-Ala-NH<sub>2</sub>]. BenchChem, [2026]. [Online PDF]. Available at: [\[https://www.benchchem.com/product/b1595228/docs#technical-support-center-purification-of-z-ala-ala-nh2\]](https://www.benchchem.com/product/b1595228/docs#technical-support-center-purification-of-z-ala-ala-nh2)

---

### Disclaimer & Data Validity:

The information provided in this document is for Research Use Only (RUO) and is strictly not intended for diagnostic or therapeutic procedures. While BenchChem strives to provide accurate protocols, we make no warranties, express or implied, regarding the fitness of this product for every specific experimental setup.

**Technical Support:** The protocols provided are for reference purposes. Unsure if this reagent suits your experiment?

**Need Industrial/Bulk Grade?** [Request Custom Synthesis Quote](#)

## BenchChem

Our mission is to be the trusted global source of essential and advanced chemicals, empowering scientists and researchers to drive progress in science and industry.

### Contact

Address: 3281 E Guasti Rd  
Ontario, CA 91761, United States  
Phone: (601) 213-4426  
Email: [info@benchchem.com](mailto:info@benchchem.com)

[Contact our Ph.D. Support Team for a compatibility check](#)

