

Foreword: Navigating the Complexities of PCB Congener-Specific Data

Author: BenchChem Technical Support Team. **Date:** April 2026

Compound of Interest

Compound Name: 2,2',3,4,4'-Pentachlorobiphenyl

CAS No.: 65510-45-4

Cat. No.: B1595222

[Get Quote](#)

Polychlorinated biphenyls (PCBs) represent a class of 209 distinct chemical congeners, each with unique structural and physicochemical properties that dictate its environmental behavior and toxicological profile.^[1] This guide focuses on **2,2',3,4,4'-Pentachlorobiphenyl**, designated as PCB-85 under the Ballschmiter and Zell numbering system. It is crucial to distinguish this congener from other similarly named pentachlorobiphenyls, such as 2,2',3,4,5'-Pentachlorobiphenyl (PCB-87), as data for one is often mistakenly attributed to the other. As a Senior Application Scientist, it is my experience that a significant challenge in the study of individual PCB congeners is the scarcity of experimentally-derived data for less common variants. This guide will synthesize the available information for PCB-85, provide authoritative context based on the known properties of PCBs as a class, and detail the established methodologies for their characterization. Where experimental data for PCB-85 is unavailable, this will be explicitly stated to maintain scientific integrity.

Molecular and Chemical Identity

A precise understanding of the molecular identity is the foundation for all physicochemical and toxicological assessments.

Table 1: Chemical Identity of **2,2',3,4,4'-Pentachlorobiphenyl** (PCB-85)

Identifier	Value	Source(s)
IUPAC Name	1,2,3-trichloro-4-(2,4-dichlorophenyl)benzene	[2]
Congener Number	PCB-85	[1]
CAS Number	65510-45-4	[2]
Molecular Formula	C ₁₂ H ₅ Cl ₅	[2]
Molecular Weight	326.4 g/mol	[2]
Canonical SMILES	<chem>C1=CC(=C(C(=C1C2=C(C=C(C=C2)Cl)Cl)Cl)Cl)Cl</chem>	[2]
InChI Key	LACXVZHAJMVESG-UHFFFAOYSA-N	[2]

The structure of PCB-85 features a biphenyl core with five chlorine substituents distributed across both phenyl rings. The substitution pattern—with two chlorine atoms in ortho positions (2 and 2')—forces a non-planar configuration, which significantly influences its biological and chemical properties.[1]

Physicochemical Properties: A Data-Driven Overview

The environmental fate, transport, and bioavailability of a PCB congener are governed by its core physicochemical properties. As noted, specific experimental data for PCB-85 is limited. The following table summarizes available computed data and expected properties based on established trends for pentachlorobiphenyls.[3][4]

Table 2: Physicochemical Properties of **2,2',3,4,4'-Pentachlorobiphenyl** (PCB-85)

Property	Value	Method	Source(s)
Physical State	Expected to be an oily liquid or waxy solid	General Observation	[5]
Melting Point	Data not available	Experimental	-
Boiling Point	Data not available	Experimental	-
Vapor Pressure	Expected to be low (<1 Pa at 25°C)	Trend Analysis	[3]
Water Solubility	Expected to be very low (<10 µg/L)	Trend Analysis	[1][6]
Octanol-Water Partition Coefficient (log K _{ow})	6.6	Computed (XLogP3)	[2]
Henry's Law Constant (H)	Data not available	Experimental	-

Causality Behind Physicochemical Trends

- **Low Water Solubility & High K_{ow}:** The high degree of chlorination and the non-polar nature of the biphenyl structure render PCB-85 highly hydrophobic (lipophilic).[7] Its calculated log K_{ow} of 6.6 indicates a strong tendency to partition from water into organic phases, such as lipids in organisms and organic matter in soil and sediment. This property is the primary driver of its bioaccumulation in food webs.[8]
- **Low Vapor Pressure:** Like other higher-chlorinated biphenyls, PCB-85 is a semi-volatile organic compound (SVOC). Its low vapor pressure means it will not readily evaporate at ambient temperatures but can be subject to long-range atmospheric transport, cycling between air, water, and soil over time.[3]

Synthesis of Individual PCB Congeners for Research

The industrial production of PCBs involved the direct chlorination of biphenyl, which resulted in complex mixtures (Aroclors).[9] For research and toxicological studies, pure, individual congeners are required. Unambiguous synthesis is typically achieved via organometallic cross-coupling reactions.

Synthetic Strategy: The Ullmann Condensation

The Ullmann condensation is a classical and effective method for synthesizing symmetrical and some unsymmetrical PCB congeners, particularly those with steric hindrance from multiple ortho-chlorine atoms.[10][11]

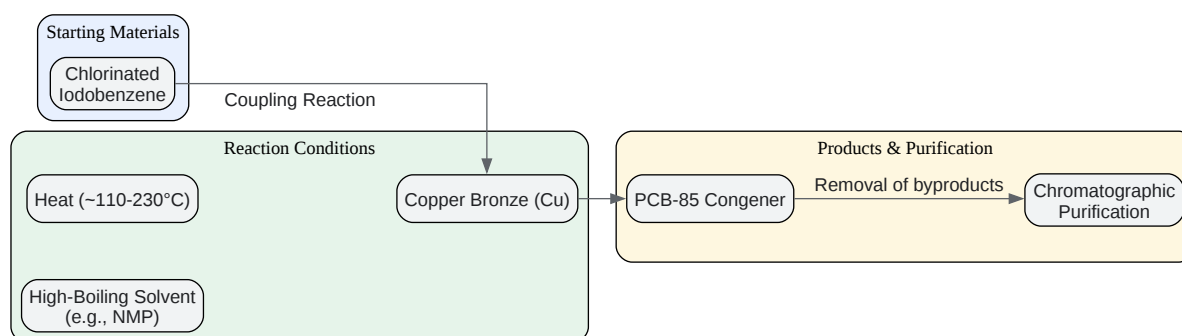

[Click to download full resolution via product page](#)

Caption: Generalized workflow for PCB-85 synthesis via Ullmann condensation.

A similar approach, the Gomberg-Bachmann reaction, involves the reaction of a diazonium salt with an arene and can also be employed for creating unsymmetrical biaryls.[12] These synthetic routes provide the high-purity standards essential for accurate analytical quantification and toxicological assessment.

Analytical Methodologies for Congener-Specific Quantification

The shift from analyzing PCBs as commercial mixtures (Aroclors) to a congener-specific approach is driven by the recognition that toxicity varies dramatically between congeners.[13] EPA Method 8082A provides a robust framework for the quantification of individual PCB congeners in environmental matrices.[9][14]

Standard Workflow for PCB-85 Analysis

The following diagram and protocol outline a self-validating system for the extraction, cleanup, and analysis of PCB-85 from a solid matrix like soil or sediment.

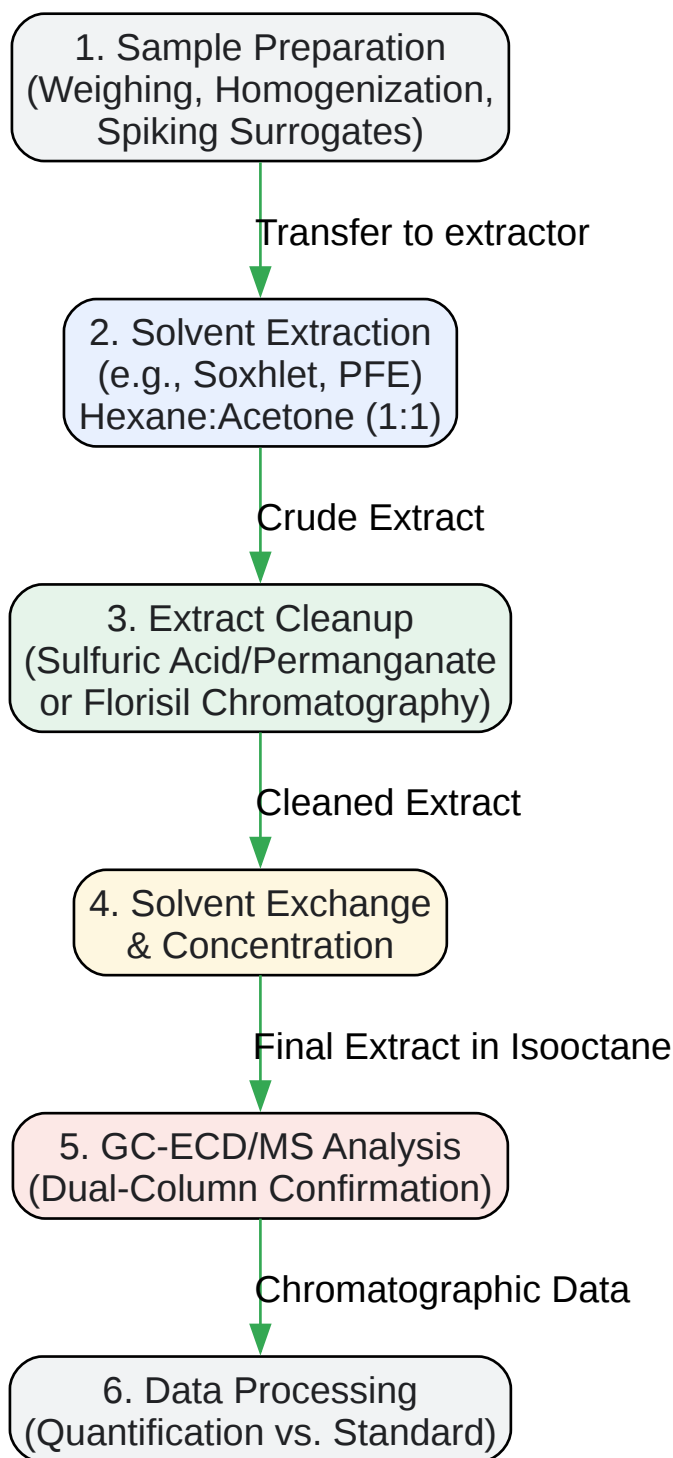

[Click to download full resolution via product page](#)

Caption: Standard analytical workflow for PCB-85 determination in solid samples.

Experimental Protocol: PCB-85 Analysis in Soil (Based on EPA Method 8082A)

This protocol explains the causality behind key steps, ensuring a self-validating and robust analytical process.

- Sample Preparation and Extraction:
 - Step 1.1: Weigh approximately 10-20 g of homogenized soil into an extraction thimble. The homogenization is critical to ensure the subsample is representative of the bulk material.
 - Step 1.2: Fortify the sample with a surrogate standard solution (e.g., tetrachloro-m-xylene, decachlorobiphenyl). Causality: Surrogates are compounds chemically similar to the analyte but not expected in the sample. Their recovery provides a quantitative measure of the efficiency of the entire extraction and cleanup process for each individual sample, acting as a crucial quality control check.[9]
 - Step 1.3: Extract the sample for 6-12 hours using a Soxhlet extractor with a 1:1 mixture of hexane and acetone. Causality: The hexane/acetone azeotrope is effective at penetrating the soil matrix and solubilizing non-polar compounds like PCBs. Soxhlet extraction ensures exhaustive removal of the analyte from the sample matrix.
- Extract Cleanup:
 - Step 2.1: Concentrate the raw extract to approximately 5 mL using a Kuderna-Danish (K-D) apparatus.
 - Step 2.2: Perform a cleanup using EPA Method 3665 (Sulfuric Acid/Permanganate). This involves partitioning the extract against concentrated sulfuric acid to remove oxidizable organic interferences, followed by a potassium permanganate step to remove remaining impurities. Causality: Environmental samples contain a complex mixture of organic compounds (e.g., lipids, humic acids) that can interfere with GC analysis. This aggressive cleanup is necessary to isolate the chemically stable PCBs, ensuring a clean chromatogram and accurate quantification.[9]

- Step 2.3 (Alternative): For less contaminated samples, cleanup can be achieved using solid-phase extraction (SPE) with Florisil. PCBs are eluted with hexane, while more polar interferences are retained.
- Final Concentration and Analysis:
 - Step 3.1: Exchange the solvent of the cleaned extract to isooctane and concentrate to a final volume of 1.0 mL. Causality: Isooctane is a suitable solvent for injection into a gas chromatograph and is compatible with the electron capture detector (ECD).
 - Step 3.2: Analyze a 1-2 μL aliquot by gas chromatography, typically using a dual-column setup with an ECD (GC-ECD).^{[15][16]} Causality: Using two columns of different polarity (e.g., a non-polar DB-5 and a mid-polarity DB-1701) provides confirmation of the analyte's identity. A peak co-eluting with the PCB-85 standard on one column is unlikely to co-elute on a second, different column, thus confirming its identity with high confidence. The ECD is highly sensitive to halogenated compounds like PCBs.

Protocol for Determination of Octanol-Water Partition Coefficient (K_{ow})

The K_{ow} is a critical parameter for environmental modeling. The Generator Column method is a reliable technique for determining K_{ow} for hydrophobic compounds like PCBs, as it avoids issues with emulsion formation common to the traditional shake-flask method.^{[17][18][19]}

Experimental Protocol: Generator Column Method (Based on OECD Guideline 123)

- Column Preparation:
 - Step 1.1: Pack a thermostated glass column with a solid support material (e.g., silanized silica).
 - Step 1.2: Prepare a solution of PCB-85 in n-octanol (pre-saturated with water).
 - Step 1.3: Coat the support material with the PCB-85/octanol solution and allow the solvent to evaporate, leaving a thin, stable film of the octanol phase on the support.

- Equilibration and Elution:
 - Step 2.1: Pump HPLC-grade water through the generator column at a slow, constant flow rate (e.g., 0.5-1.0 mL/min). Causality: As water passes over the large surface area of the coated support, it becomes saturated with PCB-85, achieving a true equilibrium between the octanol and water phases.
 - Step 2.2: Ensure the system reaches a steady state by monitoring the concentration of PCB-85 in the aqueous eluent over time until it becomes constant.
- Concentration and Analysis:
 - Step 3.1: Pass a precisely measured volume of the aqueous eluent through a solid-phase extraction (SPE) cartridge to trap the dissolved PCB-85.
 - Step 3.2: Elute the PCB-85 from the SPE cartridge with a small volume of an organic solvent (e.g., hexane).
 - Step 3.3: Analyze the resulting solution using GC-ECD, as described in Section 4.2, to determine the aqueous concentration (C_i).
- Calculation of K_{ow} :
 - Step 4.1: Accurately determine the concentration of PCB-85 in the initial n-octanol solution (C_o).
 - Step 4.2: Calculate the K_{ow} as the ratio of the concentration in octanol to the concentration in water: $K_{ow} = C_o / C_i$.

Conclusion: A Call for Further Empirical Research

2,2',3,4,4'-Pentachlorobiphenyl (PCB-85) is a member of a class of persistent and bioaccumulative environmental contaminants. While its molecular identity is well-defined and robust analytical methods exist for its quantification, a significant gap remains in the experimental determination of its fundamental physicochemical properties. The values for properties such as water solubility, vapor pressure, and Henry's Law constant are currently inferred from general trends rather than direct measurement. As risk assessment models

become increasingly sophisticated, the demand for high-quality, congener-specific experimental data will only grow. This guide provides the established frameworks for generating such data, underscoring the necessity for continued research to fully characterize the environmental behavior of this and other less-studied PCB congeners.

References

- National Center for Biotechnology Information (NCBI). (n.d.). Polychlorinated Biphenyls and Polybrominated Biphenyls - IARC Monographs on the Evaluation of Carcinogenic Risks to Humans - Volume 107. Retrieved from [\[Link\]](#)
- Agency for Toxic Substances and Disease Registry (ATSDR). (2000). Toxicological Profile for Polychlorinated Biphenyls (PCBs). Retrieved from [\[Link\]](#)
- Code of Federal Regulations. (n.d.). 40 CFR § 799.6756 - TSCA partition coefficient (n-octanol/water), generator column method. Retrieved from [\[Link\]](#)
- Australian and New Zealand Environment and Conservation Council (ANZECC). (2000). Polychlorinated biphenyls in freshwater and marine water. Retrieved from [\[Link\]](#)
- Telu, S., Parkin, S., Robertson, L. W., & Lehmler, H. J. (2010). Improved Syntheses of Non-dioxin-like Polychlorinated Biphenyls (PCBs) and Some of Their Sulfur-containing Metabolites. *Beilstein Journal of Organic Chemistry*, 6, 84. Retrieved from [\[Link\]](#)
- Wikipedia. (n.d.). Gomberg–Bachmann reaction. Retrieved from [\[Link\]](#)
- Shiu, W. Y., & Mackay, D. (1986). A Critical Review of Aqueous Solubilities, Vapor Pressures, Henry's Law Constants, and Octanol–Water Partition Coefficients of the Polychlorinated Biphenyls. *Journal of Physical and Chemical Reference Data*, 15(2), 911-929. Retrieved from [\[Link\]](#)
- U.S. Environmental Protection Agency (EPA). (2007). Method 8082A: Polychlorinated Biphenyls (PCBs) by Gas Chromatography. Retrieved from [\[Link\]](#)
- Bhangare, R. C., Ajmal, P. Y., Rathod, T. D., Tiwari, M., & Sahu, S. K. (2018). Experimental and Theoretical Determination of Henry's Law Constant for Polychlorinated Biphenyls: Its

Dependence on Solubility and Degree of Chlorination. Archives of Environmental Contamination and Toxicology, 76(1), 142-152. Retrieved from [[Link](#)]

- Lehmler, H. J., et al. (2010). Synthesis of Sterically Hindered Polychlorinated Biphenyl Derivatives. Molecules, 15(7), 5063-5076. Retrieved from [[Link](#)]
- Fang, F., Chu, S., & Hong, C. S. (2006). Air-water Henry's law constants for PCB congeners: Experimental determination and modeling of structure-property relationship. Analytical Chemistry, 78(15), 5412-5418. Retrieved from [[Link](#)]
- Restek Corporation. (2020). Method 8082A: Polychlorinated Biphenyls (PCBs) Analysis by GC. Retrieved from [[Link](#)]
- Agilent Technologies. (n.d.). Polychlorinated Biphenyls (PCB) Analysis in Environmental Samples by GC/MS. Retrieved from [[Link](#)]
- Stenutz, R. (n.d.). 2,2',4,5,5'-pentachlorobiphenyl. Retrieved from [[Link](#)]
- Scribd. (n.d.). PCB Analysis Method 8082A Guide. Retrieved from [[Link](#)]
- U.S. Environmental Protection Agency (EPA). (2007). Method 8082A: Polychlorinated Biphenyls (PCBs) by Gas Chromatography, part of Test Methods for Evaluating Solid Waste, Physical/. Retrieved from [[Link](#)]
- Wasik, S. P., Tewari, Y. B., Miller, M. M., & Martire, D. E. (1981). Generator Columns and High Pressure Liquid Chromatography for Determining Aqueous Solubilities and Octanol-Water Partition Coefficients of Hydrophobic Substances. Journal of Research of the National Bureau of Standards, 86(5), 583-588. Retrieved from [[Link](#)]
- SynArchive. (n.d.). Ullmann Condensation. Retrieved from [[Link](#)]
- Bamford, H. A., Poster, D. L., & Baker, J. E. (2006). Henry's Law Constants for Eleven Polychlorinated Biphenyls at 20 °C. Journal of Chemical & Engineering Data, 51(4), 1363-1367. Retrieved from [[Link](#)]
- Wikipedia. (n.d.). Polychlorinated biphenyl. Retrieved from [[Link](#)]
- Wikipedia. (n.d.). Ullmann condensation. Retrieved from [[Link](#)]

- Shiu, W. Y., & Mackay, D. (1986). A Critical Review of Aqueous Solubilities, Vapor Pressures, Henry's Law Constants, and Octanol–Water Partition Coefficients of the Polychlorinated. *Journal of Physical and Chemical Reference Data*, 15(2). Retrieved from [\[Link\]](#)
- University of California, Davis. (n.d.). The Octanol-Water Partition Constant: Using HPLC Retention Times to Estimate an Important Physicochemical Parameter. Retrieved from [\[Link\]](#)
- National Center for Biotechnology Information (NCBI). (n.d.). Toxicological Profile for Polychlorinated Biphenyls (PCBs) - Chemical and Physical Information. Retrieved from [\[Link\]](#)
- Fendinger, N. J., & Glotfelty, D. E. (1990). Henry's law constants for selected pesticides, PAHs and PCBs. *Environmental Toxicology and Chemistry*, 9(6), 731-735. Retrieved from [\[Link\]](#)
- PubChem. (n.d.). Polychlorinated Biphenyls. Retrieved from [\[Link\]](#)
- Max-Planck-Gesellschaft. (n.d.). Henry's Law Constants. Retrieved from [\[Link\]](#)
- PubChem. (n.d.). **2,2',3,4,4'-Pentachlorobiphenyl**. Retrieved from [\[Link\]](#)
- ECETOC. (n.d.). APPENDIX B: MEASUREMENT OF PARTITIONING (KOW). Retrieved from [\[Link\]](#)
- Exposome-Explorer. (n.d.). PCB-87 (Compound). Retrieved from [\[Link\]](#)
- PubChem. (n.d.). 2,2',3,4',5'-Pentachlorobiphenyl. Retrieved from [\[Link\]](#)
- Gomberg-Bachmann Reaction: Synthesis of Biaryls. (2019). *Organic Syntheses*, 96, 254-268. Retrieved from [\[Link\]](#)
- ECETOC. (n.d.). APPENDIX B: MEASUREMENT OF PARTITIONING (KOW). Retrieved from [\[Link\]](#)
- McFarland, V. A., & Clarke, J. U. (1989). Environmental occurrence, abundance, and potential toxicity of polychlorinated biphenyl congeners: considerations for a congener-specific analysis. *Environmental Health Perspectives*, 81, 225-239. Retrieved from [\[Link\]](#)

- ResearchGate. (n.d.). Recent advances in Gomberg-Backmann biaryl synthesis. Retrieved from [[Link](#)]
- Bidleman, T. F. (1984). Retention-index based vapor pressure estimation for polychlorobiphenyl (PCB) by gas chromatography. *Analytical Chemistry*, 56(13), 2490-2496. Retrieved from [[Link](#)]
- PubChem. (n.d.). 2,2',3,4,5-Pentachlorobiphenyl. Retrieved from [[Link](#)]

Need Custom Synthesis?

BenchChem offers custom synthesis for rare earth carbides and specific isotopic labeling.

Email: info@benchchem.com or [Request Quote Online](#).

Sources

- 1. atsdr.cdc.gov [atsdr.cdc.gov]
- 2. Amanote [app.amanote.com]
- 3. Polychlorinated biphenyl - Wikipedia [en.wikipedia.org]
- 4. researchgate.net [researchgate.net]
- 5. rsc.org [rsc.org]
- 6. 1. EXPOSURE DATA - Polychlorinated Biphenyls and Polybrominated Biphenyls - NCBI Bookshelf [ncbi.nlm.nih.gov]
- 7. CAS 38380-02-8: PCB 87 | CymitQuimica [cymitquimica.com]
- 8. Polychlorinated biphenyls in freshwater and marine water [waterquality.gov.au]
- 9. NEMI Method Summary - 8082A [nemi.gov]
- 10. Improved Syntheses of Non-dioxin-like Polychlorinated Biphenyls (PCBs) and Some of Their Sulfur-containing Metabolites - PMC [pmc.ncbi.nlm.nih.gov]
- 11. Synthesis of Sterically Hindered Polychlorinated Biphenyl Derivatives - PMC [pmc.ncbi.nlm.nih.gov]
- 12. Gomberg–Bachmann reaction - Wikipedia [en.wikipedia.org]
- 13. 2,2',3,4,5'-Pentachlorobiphenyl | C₁₂H₅Cl₅ | CID 38014 - PubChem [pubchem.ncbi.nlm.nih.gov]

- [14. epa.gov \[epa.gov\]](#)
- [15. Method 8082A: Polychlorinated Biphenyls \(PCBs\) Analysis by GC \[discover.restek.com\]](#)
- [16. agilent.com \[agilent.com\]](#)
- [17. 40 CFR § 799.6756 - TSCA partition coefficient \(n-octanol/water\), generator column method. | Electronic Code of Federal Regulations \(e-CFR\) | US Law | LII / Legal Information Institute \[law.cornell.edu\]](#)
- [18. nvlpubs.nist.gov \[nvlpubs.nist.gov\]](#)
- [19. web.viu.ca \[web.viu.ca\]](#)
- To cite this document: BenchChem. [Foreword: Navigating the Complexities of PCB Congener-Specific Data]. BenchChem, [2026]. [Online PDF]. Available at: [\[https://www.benchchem.com/product/b1595222/docs#foreword-navigating-the-complexities-of-pcb-congener-specific-data\]](https://www.benchchem.com/product/b1595222/docs#foreword-navigating-the-complexities-of-pcb-congener-specific-data)

Disclaimer & Data Validity:

The information provided in this document is for Research Use Only (RUO) and is strictly not intended for diagnostic or therapeutic procedures. While BenchChem strives to provide accurate protocols, we make no warranties, express or implied, regarding the fitness of this product for every specific experimental setup.

Technical Support: The protocols provided are for reference purposes. Unsure if this reagent suits your experiment?

Need Industrial/Bulk Grade? [Request Custom Synthesis Quote](#)

BenchChem

Our mission is to be the trusted global source of essential and advanced chemicals, empowering scientists and researchers to drive progress in science and industry.

Contact

Address: 3281 E Guasti Rd
Ontario, CA 91761, United States
Phone: (601) 213-4426
Email: info@benchchem.com

Contact our Ph.D. Support Team for a compatibility check