

Technical Support Center: 2-Phenylpropyl Butyrate Synthesis

Author: BenchChem Technical Support Team. **Date:** May 2026

Compound of Interest

Compound Name: 2-Phenylpropyl butyrate

CAS No.: 80866-83-7

Cat. No.: B1594372

[Get Quote](#)

Topic: Optimization of Esterification Yield for **2-Phenylpropyl Butyrate** Ticket ID: #EST-2PPB-OPT Assigned Specialist: Senior Application Scientist, Process Chemistry Division Status: Open

Executive Summary & Chemical Context

Target Molecule: **2-Phenylpropyl butyrate** (CAS: 80866-83-7) Substrates: 2-Phenyl-1-propanol (Hydratropic alcohol) + Butyric Acid Primary Challenge: The substrate, 2-phenyl-1-propanol, is a primary alcohol with significant

-branching (a phenyl and a methyl group at the

-position). While less sterically hindered than secondary alcohols, this branching creates a "neopentyl-like" steric environment that retards nucleophilic attack, making standard Fischer esterification sluggish and prone to equilibrium stalls [1].

This guide addresses the specific kinetic and thermodynamic barriers preventing high yields (>90%) and provides validated protocols to overcome them.

Troubleshooting Guide (Q&A)

Q1: My reaction conversion plateaus at 60-65% regardless of reaction time. Why?

Diagnosis: Thermodynamic Equilibrium Limitation. Technical Explanation: Esterification is a reversible reaction with an equilibrium constant (

) typically near 4. The accumulation of water (a byproduct) drives the reverse hydrolysis reaction. Solution: You must break the equilibrium by removing one product (water) or using a large excess of one reagent.

- Chemical Method: Use a Dean-Stark trap with an azeotropic solvent (Toluene or Cyclohexane) to continuously remove water.
- Enzymatic Method: Add activated Molecular Sieves (3Å or 4Å) directly to the reaction media. This is often more effective for high-boiling substrates where azeotropic distillation is energy-intensive [2].

Q2: I am using sulfuric acid (H₂SO₄), but the product is dark, and yield is low due to "tar" formation.

Diagnosis: Acid-Catalyzed Side Reactions. Technical Explanation: Strong mineral acids at high temperatures can cause:

- Dehydration: The
 - phenyl group stabilizes carbocation intermediates, increasing the risk of dehydration to
 - methylstyrene derivatives.
- Oxidation/Polymerization: Phenolic impurities or the aromatic ring itself can undergo oxidative coupling under harsh acidic conditions. Solution: Switch to
 - Toluenesulfonic acid (pTSA) (milder) or, preferably, an Immobilized Lipase (e.g., Novozym 435). Enzymatic synthesis operates at neutral pH and 40-60°C, eliminating charring and side reactions [3].

Q3: The reaction is extremely slow (taking >24 hours).

Diagnosis: Steric Hindrance (

-branching). Technical Explanation: The bulky phenyl group at the C2 position shields the C1 hydroxyl group. In a standard tetrahedral intermediate, this bulk creates significant torsional strain. Solution:

- Increase Temperature: If using chemical catalysis, ensure vigorous reflux.
- Catalyst Loading: For enzymatic routes, increase lipase loading to 10-15% w/w relative to the substrate.
- Acyl Donor Modification: Switch from Butyric Acid to Butyric Anhydride. The reaction becomes irreversible and thermodynamically favorable, though it generates butyric acid as a byproduct (which must be scavenged or recycled) [4].

Q4: I have a persistent emulsion during the workup.

Diagnosis: Surfactant Effect. Technical Explanation: **2-Phenylpropyl butyrate** has a lipophilic tail (phenylpropyl) and a polar ester head, acting as a weak surfactant. Solution:

- Wash Protocol: Do not use pure water. Use saturated NaCl (brine) for all aqueous washes to increase ionic strength and force phase separation.
- Drying: Filter the organic phase through a pad of Celite/MgSO₄ before solvent evaporation to break micro-emulsions.

Validated Experimental Protocols

Method A: Green Enzymatic Synthesis (Recommended for Purity)

Best for: High purity requirements, fragrance/flavor applications, avoiding thermal degradation.

Reagents:

- 2-Phenyl-1-propanol (1.0 eq)

- Butyric Acid (1.2 eq)
- Catalyst: Novozym 435 (Immobilized *Candida antarctica* Lipase B) - 10% w/w of alcohol.
- Solvent:
-Heptane (or solvent-free).
- Water Scavenger: Molecular Sieves 4Å (Activated).

Step-by-Step:

- Activation: Dry Molecular Sieves at 250°C for 3 hours prior to use.
- Setup: In a glass vial or reactor, combine 2-Phenyl-1-propanol (e.g., 10 mmol) and Butyric Acid (12 mmol) in
-Heptane (20 mL).
- Initiation: Add Novozym 435 (approx. 200 mg) and Molecular Sieves (1.0 g).
- Incubation: Shake or stir gently (150-200 rpm) at 50°C. Note: Vigorous stirring can grind the immobilized enzyme support, reducing recyclability.
- Monitoring: Monitor by GC-FID or TLC (Hexane:EtOAc 9:1). Conversion should reach >95% within 6-8 hours.
- Workup: Filter off the enzyme and sieves. (Save enzyme for washing/reuse). Wash filtrate with sat. NaHCO₃ (to remove excess acid) and Brine.
- Purification: Concentrate in vacuo. Distillation is rarely needed due to high specificity.

Method B: Scalable Azeotropic Esterification

Best for: Large-scale production, lower cost sensitivity.

Reagents:

- 2-Phenyl-1-propanol (1.0 eq)

- Butyric Acid (1.5 eq)
- Catalyst:
 - Toluenesulfonic acid monohydrate (pTSA) (1-2 mol%)
- Solvent: Toluene (Reaction conc.[1] ~0.5 M)[2][3]

Step-by-Step:

- Setup: Equip a round-bottom flask with a Dean-Stark trap and reflux condenser.
- Charging: Add alcohol, butyric acid, pTSA, and Toluene.
- Reflux: Heat to vigorous reflux (approx. 115-120°C bath temp). Ensure toluene is condensing and water is separating in the trap.
- Reaction Time: Run for 12-16 hours. Drain water from the trap periodically.
- Quench: Cool to room temperature.
- Wash: Wash organic layer with 10% Na₂CO₃ (2x) to remove pTSA and excess butyric acid. Wash with Brine (1x).
- Isolation: Dry over Na₂SO₄, filter, and concentrate. Vacuum distillation is required to remove trace high-boiling impurities.

Data Comparison

Metric	Method A: Enzymatic (Lipase)	Method B: Chemical (pTSA)
Yield (Isolated)	92 - 96%	80 - 85%
Reaction Temp	50°C	115°C (Reflux)
Reaction Time	6 - 8 Hours	12 - 16 Hours
Purity (Crude)	High (>98%)	Moderate (Requires Distillation)
E-Factor (Waste)	Low (Recyclable Catalyst)	High (Solvent/Wash waste)
Color	Colorless	Often Light Yellow/Amber

Visualizations

Figure 1: Mechanistic Pathway & Steric Challenge

This diagram illustrates why the enzymatic route bypasses the steric issues of the chemical route via the Acyl-Enzyme intermediate.

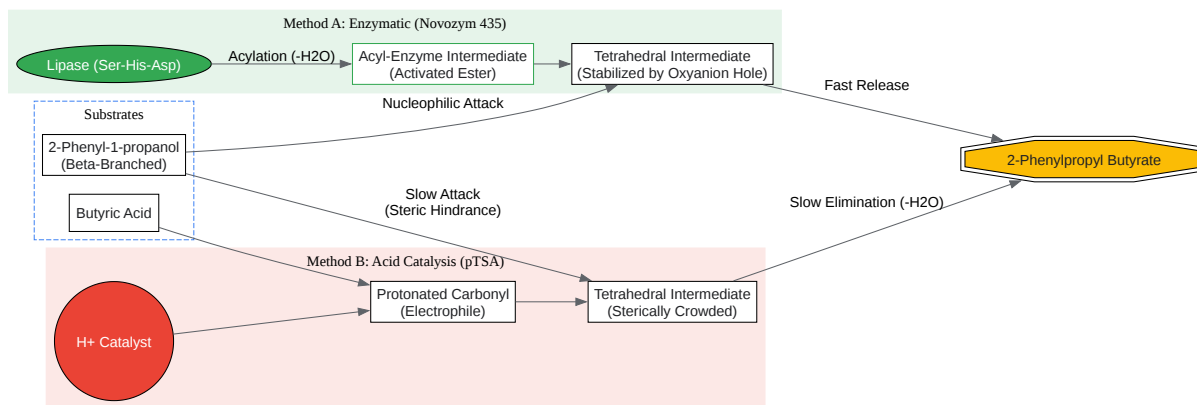

[Click to download full resolution via product page](#)

Caption: Comparison of Enzyme-stabilized transition state vs. Sterically hindered acid-catalyzed pathway.

Figure 2: Troubleshooting Decision Tree

Follow this logic flow to resolve low yield issues.

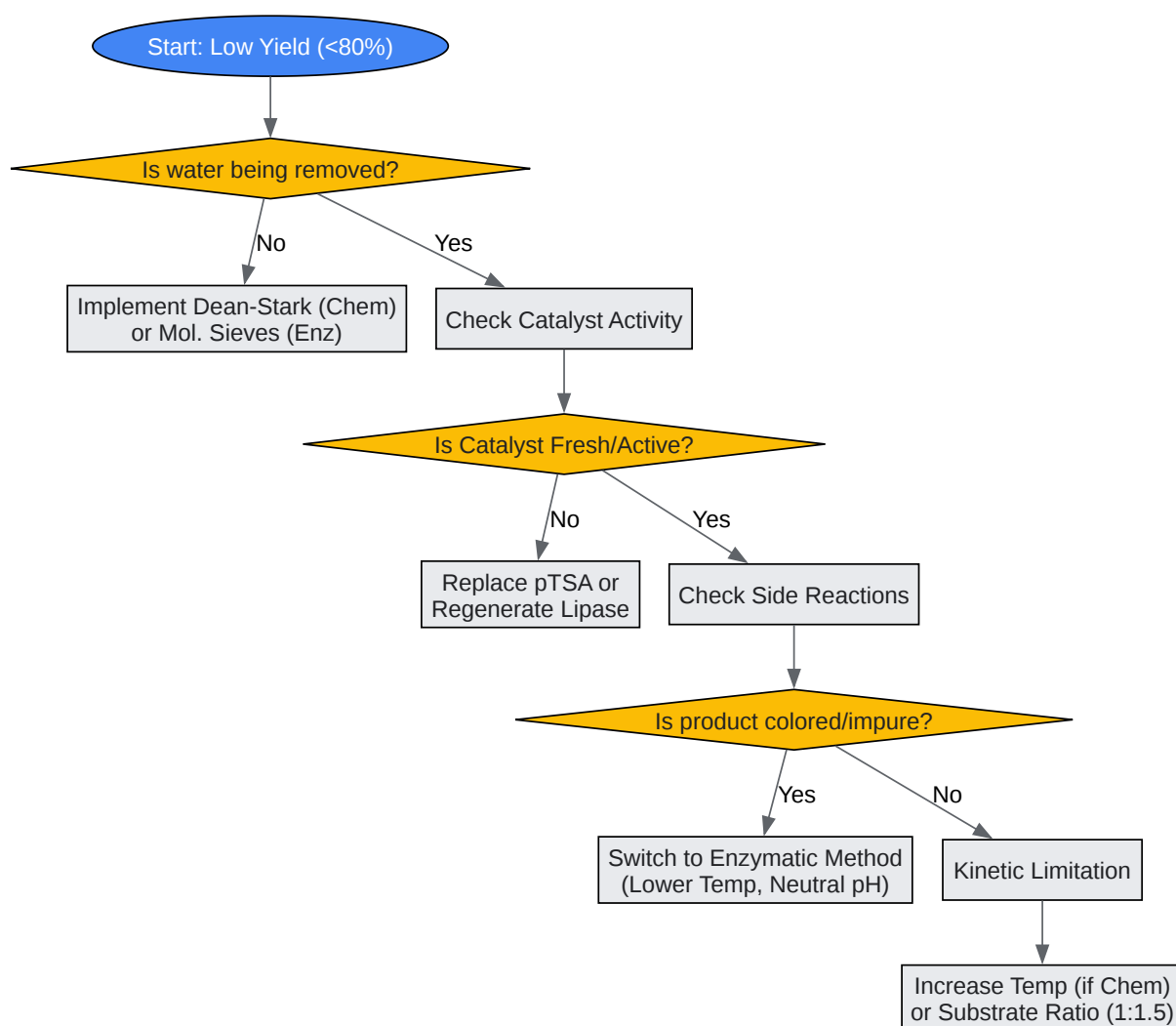

[Click to download full resolution via product page](#)

Caption: Diagnostic workflow for identifying the root cause of yield loss in esterification.

References

- Steric Effects in Esterification: Smith, M. B., & March, J. (2007). March's Advanced Organic Chemistry: Reactions, Mechanisms, and Structure. Wiley-Interscience.
- Enzymatic Esterification Optimization: Veríssimo, L. A. A., et al. (2015). "Esterification yield (%) as a function of time for butyl butyrate synthesis catalyzed by *Aspergillus niger* lipase." ResearchGate.[4] Available at: [\[Link\]](#)[4]
- Lipase Catalysis for Phenolic Esters: MDPI. (2020). "Synthesis of Industrially Useful Phenolic Compounds Esters by Means of Biocatalysts." Microorganisms. Available at: [\[Link\]](#)[5][6]
- Kinetic Resolution & Esterification: Karadeniz, F., et al. (2010).[5] "Kinetic resolution of racemic 1-phenyl 1-propanol by lipase catalyzed enantioselective esterification reaction." Artificial Cells, Blood Substitutes, and Biotechnology.[5] Available at: [\[Link\]](#) (Demonstrates the efficacy of Novozym 435 for phenyl-substituted alcohols).
- **2-Phenylpropyl Butyrate** Properties: PubChem Database. "**2-Phenylpropyl butyrate** | C₁₃H₁₈O₂". Available at: [\[Link\]](#)

Need Custom Synthesis?

BenchChem offers custom synthesis for rare earth carbides and specific isotopic labeling.

Email: info@benchchem.com or [Request Quote Online](#).

Sources

1. Lipase Immobilized on MCFs as Biocatalysts for Kinetic and Dynamic Kinetic Resolution of sec-Alcohols [mdpi.com]
2. Reductive enzymatic dynamic kinetic resolution affording 115 g/L (S)-2-phenylpropanol - PMC [pmc.ncbi.nlm.nih.gov]
3. 2-Phenylpropyl butyrate | C₁₃H₁₈O₂ | CID 576263 - PubChem [pubchem.ncbi.nlm.nih.gov]
4. researchgate.net [researchgate.net]
5. Kinetic resolution of racemic 1-phenyl 1-propanol by lipase catalyzed enantioselective esterification reaction - PubMed [pubmed.ncbi.nlm.nih.gov]

- [6. jocpr.com \[jocpr.com\]](#)
- To cite this document: BenchChem. [Technical Support Center: 2-Phenylpropyl Butyrate Synthesis]. BenchChem, [2026]. [Online PDF]. Available at: [<https://www.benchchem.com/product/b1594372/docs#technical-support-center-2-phenylpropyl-butyrate-synthesis>]

Disclaimer & Data Validity:

The information provided in this document is for Research Use Only (RUO) and is strictly not intended for diagnostic or therapeutic procedures. While BenchChem strives to provide accurate protocols, we make no warranties, express or implied, regarding the fitness of this product for every specific experimental setup.

Technical Support: The protocols provided are for reference purposes. Unsure if this reagent suits your experiment?

Need Industrial/Bulk Grade? [Request Custom Synthesis Quote](#)

BenchChem

Our mission is to be the trusted global source of essential and advanced chemicals, empowering scientists and researchers to drive progress in science and industry.

Contact

Address: 3281 E Guasti Rd
Ontario, CA 91761, United States
Phone: (601) 213-4426
Email: info@benchchem.com

[Contact our Ph.D. Support Team for a compatibility check](#)