

# Technical Guide: Optimizing Sintering Temperatures for Silver Perfluorooctanoate Inks

**Author:** BenchChem Technical Support Team. **Date:** May 2026

## Compound of Interest

Compound Name: Silver perfluorooctanoate

CAS No.: 335-93-3

Cat. No.: B1594822

[Get Quote](#)

## Core Chemistry & Mechanism

### Silver Perfluorooctanoate (

) functions as a MOD precursor. Upon heating, it does not merely "dry"; it undergoes a chemical reduction reaction where the organic ligand acts as the reducing agent or leaves as a volatile byproduct, leaving behind metallic silver.[1]

The Decomposition Pathway:

- Solvent Evaporation (< 100°C): Removal of carrier solvents (often alcohols or ketones).
- Ligand Decarboxylation (~140°C - 190°C): The bond cleaves. The perfluorinated chain ( ) detaches, often releasing and fluorinated volatiles.

- Nucleation & Sintering (> 200°C): Silver atoms nucleate into nanoparticles, which then sinter (necking and grain growth) to form a conductive percolation network.

## Experimental Protocol: The Sintering Profile

Do not use a simple "ramp-to-peak" profile. AgPFO requires a stepped profile to prevent defects caused by rapid gas evolution (fluorinated volatiles).

### Recommended Thermal Profile

Phase	Temperature Range	Duration	Purpose	Critical Control
1. Drying	60°C – 80°C	10–15 min	Remove carrier solvent.	Prevent "skinning" (trapping solvent inside).
2. Decomposition	140°C – 160°C	20 min	Initiate decarboxylation of AgPFO.	Ventilation Required. Fluorinated byproducts release here.
3. Sintering	200°C – 250°C	30–60 min	Grain growth and densification.	Higher temp = lower resistivity but higher substrate stress.
4. Annealing	Cool to RT	Slow Ramp	Prevent thermal shock/cracking.	Avoid rapid quenching.

“

*Safety Warning: The thermal decomposition of perfluorooctanoate can release perfluorinated volatiles and trace hydrogen fluoride (HF). Always operate in a fume hood with appropriate filtration.*

## Process Visualization

The following diagram illustrates the transformation from molecular ink to conductive trace, highlighting failure modes at each stage.

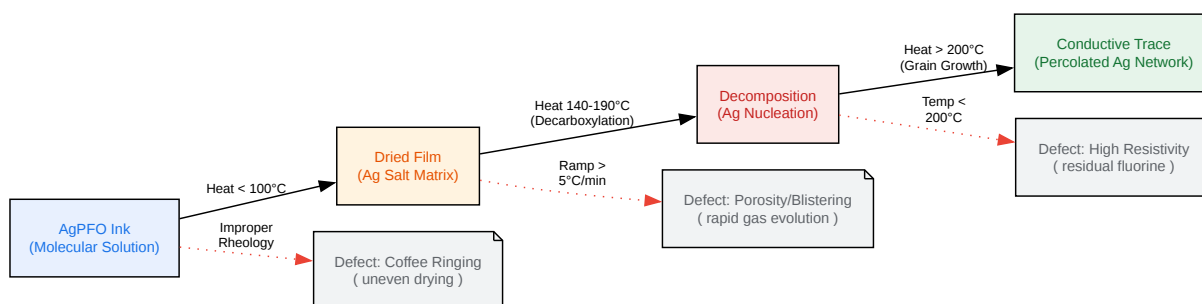

[Click to download full resolution via product page](#)

Figure 1: Transformation pathway of AgPFO ink showing critical transition states and associated failure modes.

## Troubleshooting & FAQs

### Category: Conductivity & Resistivity

Q: My sintered traces are dark/black and non-conductive. What went wrong?

- **Diagnosis:** Incomplete decomposition. The black color indicates the formation of small silver nanoparticles that have not yet sintered into a connected network, or the presence of residual carbon/fluorine insulating layers.
- **Solution:** Increase the Sintering Phase temperature by 20°C or extend the dwell time. Ensure you have reached at least 200°C, as the fluorinated ligand is thermally stable and requires higher energy to fully detach compared to non-fluorinated analogues like silver neodecanoate [1].

Q: I achieved conductivity, but it drifts over time. Why?

- **Diagnosis:** Micro-cracking or oxidation. If the substrate is flexible (e.g., PET/Kapton), mechanical mismatch during cooling can cause micro-cracks.
- **Solution:** Implement a slower cooling ramp (annealing). Alternatively, verify if the fluorine residues are reacting with environmental moisture; ensure the decomposition step (Phase 2) is complete to remove all reactive species.

## Category: Adhesion & Wetting

Q: The ink beads up or dewets from the substrate before drying.

- **Diagnosis:** Surface energy mismatch. AgPFO contains a perfluorinated chain, which is inherently low-surface-energy (hydrophobic/oleophobic). However, the solvent system dictates wetting.
- **Solution:**
  - **Substrate Treatment:** Plasma treat (O<sub>2</sub> or Argon) the substrate to increase its surface energy.
  - **Solvent Modification:** If you formulated the ink yourself, add a wetting agent or switch to a solvent with lower surface tension compatible with the fluorinated complex.

## Category: Morphology (Bubbles/Pinholes)

Q: The final film has "blisters" or pinholes.

- **Diagnosis:** Solvent boiling or rapid outgassing. If you ramp temperature too quickly, the and fluorinated gases generated during decomposition become trapped under a solidified surface "skin," eventually bursting out.
- **Solution:** Reduce the ramp rate between Phase 1 and Phase 2. Use a "step" profile (hold at 140°C for 10 mins) to allow gases to escape slowly before the metal network densifies.

## References

- **Decomposition Mechanisms of Fluorinated Carboxylates**
  - Title: Thermal decomposition behavior of perfluorooctanoic acid and its salts.[2]
  - Context: Establishes that perfluorinated carboxylates generally require temperatures >150°C for significant decarboxylation and that silver salts catalyze this process rel
  - Source:
- **General MOD Ink Sintering Principles**
  - Title: Silver nanoparticle ink technology: st
  - Context: Defines the sintering mechanism (neck formation vs. grain growth) and the impact of organic ligands on resistivity.
  - Source:
- **Silver Carboxylate Precursors**
  - Title: Method of making silver carboxylates for conductive ink (P
  - Context: Describes the self-reduction mechanism of silver carboxylates and the typical temperature windows (130°C–250°C) required for conductivity.
  - Source:

### **Need Custom Synthesis?**

BenchChem offers custom synthesis for rare earth carbides and specific isotopic labeling.

Email: [info@benchchem.com](mailto:info@benchchem.com) or [Request Quote Online](#).

## Sources

- [1. US9198288B2 - Method of making silver carboxylates for conductive ink - Google Patents \[patents.google.com\]](#)
- [2. researchgate.net \[researchgate.net\]](#)
- To cite this document: BenchChem. [Technical Guide: Optimizing Sintering Temperatures for Silver Perfluorooctanoate Inks]. BenchChem, [2026]. [Online PDF]. Available at: [\[https://www.benchchem.com/product/b1594822/docs#technical-guide-optimizing-sintering-temperatures-for-silver-perfluorooctanoate-inks\]](https://www.benchchem.com/product/b1594822/docs#technical-guide-optimizing-sintering-temperatures-for-silver-perfluorooctanoate-inks)

---

### Disclaimer & Data Validity:

The information provided in this document is for Research Use Only (RUO) and is strictly not intended for diagnostic or therapeutic procedures. While BenchChem strives to provide accurate protocols, we make no warranties, express or implied, regarding the fitness of this product for every specific experimental setup.

**Technical Support:** The protocols provided are for reference purposes. Unsure if this reagent suits your experiment?

**Need Industrial/Bulk Grade?** [Request Custom Synthesis Quote](#)

## BenchChem

Our mission is to be the trusted global source of essential and advanced chemicals, empowering scientists and researchers to drive progress in science and industry.

### Contact

Address: 3281 E Guasti Rd

Ontario, CA 91761, United States

Phone: (601) 213-4426

Email: [info@benchchem.com](mailto:info@benchchem.com)

Contact our Ph.D. Support Team for a compatibility check