

Reproducibility of results using 5-Methylorotic acid selection

Author: BenchChem Technical Support Team. **Date:** May 2026

Compound of Interest

Compound Name: 5-Methylorotic acid

CAS No.: 3993-73-5

Cat. No.: B1594833

[Get Quote](#)

Technical Guide: Reproducibility in URA3 Counter-Selection (5-FOA vs. 5-MOA)

Executive Summary

This guide addresses the critical parameters required to achieve reproducible negative selection in yeast genetics (*Saccharomyces cerevisiae* and *Candida* spp.). While 5-Fluoroorotic Acid (5-FOA) is the gold standard for URA3 counter-selection, confusion with its analog **5-Methylorotic Acid** (5-MOA) is a frequent source of experimental failure. This document compares the mechanistic action of both compounds, provides a self-validating protocol for 5-FOA selection, and analyzes the specific causes of background growth ("breakthrough") that compromise data integrity.

Mechanistic Distinction: 5-FOA vs. 5-MOA

To ensure reproducibility, researchers must understand that 5-FOA and 5-MOA are not interchangeable. They interact with the pyrimidine biosynthesis pathway differently.

- 5-Fluoroorotic Acid (5-FOA): A "suicide substrate." The enzyme Orotidine-5'-phosphate decarboxylase (encoded by URA3) converts 5-FOA into 5-Fluorouracil (5-FU), a highly toxic

compound that incorporates into RNA and inhibits thymidylate synthase, causing cell death. This allows for the selection of ura3⁻ cells (which cannot perform this conversion and survive).

- **5-Methylorotic Acid (5-MOA):** A structural analog often used in crystallographic studies or as a competitive inhibitor. Unlike 5-FOA, the metabolic product of 5-MOA is generally non-toxic or significantly less toxic to wild-type yeast. Consequently, using 5-MOA for counter-selection results in massive "false positive" background growth, as URA3⁺ cells are not effectively killed.

Pathway Visualization

The following diagram illustrates the lethal conversion pathway of 5-FOA compared to the non-lethal processing of 5-MOA.

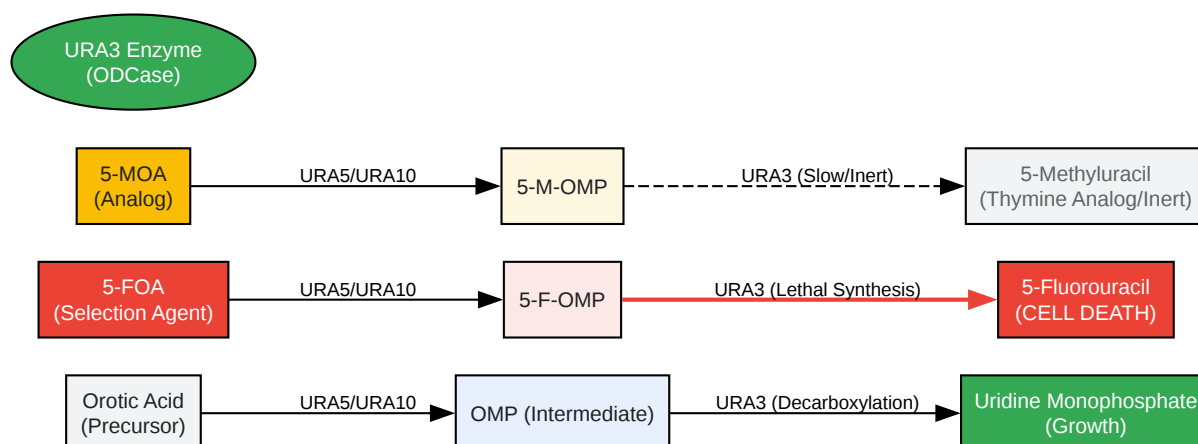

[Click to download full resolution via product page](#)

Caption: The URA3-mediated decarboxylation of 5-FOA yields toxic 5-FU, whereas 5-MOA yields non-toxic products, failing selection.

Comparative Performance Analysis

The table below summarizes why 5-FOA is the requisite agent for reproducibility and where 5-MOA fails.

Feature	5-Fluoroorotic Acid (5-FOA)	5-Methylorotic Acid (5-MOA)	5-Fluorouracil (5-FU)
Primary Application	Negative selection for URA3 loss (plasmid shuffling, gene deletion).	Crystallography; Competitive inhibition studies; Not for selection.	General cytotoxicity; Counter-selection in upp strains (bacteria).
Mechanism of Action	Converted by ODCase (URA3) to toxic 5-FU intracellularly.	Substrate analog; acts as a weak inhibitor or inert metabolite.	Directly toxic; does not require URA3 for activation (less specific).
Selection Stringency	High. Kills >99% of URA3+ cells.	None/Low. URA3+ cells survive and grow.	Variable. High background due to transport efficiency differences.
Solubility	Low in water; requires heat or DMSO.[1]	Low in water; requires alkaline pH or DMSO.	Moderate solubility.
Reproducibility Risk	pH sensitivity; degradation at >65°C if prolonged.	Total Failure: Users often mistake it for 5-FOA.	Cross-feeding effects; transport mutations.

Validated Protocol: High-Stringency 5-FOA Selection

To guarantee reproducible results, you must control the acidity and concentration of the selection medium. 5-FOA activity is pH-dependent; if the media is too acidic, the drug precipitates or becomes less effective.

Reagents Required

- 5-FOA Monohydrate: High purity (>98%).[1]
- Yeast Nitrogen Base (YNB): Without amino acids and ammonium sulfate.
- Drop-out Mix: Complete supplement mixture (CSM) minus Uracil.

- Uracil: Added to support the growth of the *ura3-* cells you are selecting for.

Step-by-Step Workflow

- Base Media Preparation (2X Concentration):
 - Dissolve agar (20g/L) in 500mL deionized water. Autoclave at 121°C for 15 min.
- 5-FOA Solution Preparation (Critical Step):
 - In a separate flask, mix:
 - YNB (6.7g/L final conc)
 - Glucose (20g/L final conc)
 - Amino acid dropout powder (-Ura)
 - Uracil (50 mg/L final conc) — Essential: The survivors are *ura3-* auxotrophs and need uracil to grow.
 - 5-FOA (1.0 g/L final conc)
 - Add water to ~400mL.
 - Heated Dissolution: Heat to 50-60°C with stirring. Do not boil 5-FOA for extended periods. If it does not dissolve, add small volumes of sterile water or adjust pH slightly to 4.5-5.0.
 - Filter Sterilization: Once dissolved, filter sterilize (0.22 µm) the 5-FOA/nutrient mix. Do not autoclave 5-FOA directly if possible, as thermal degradation varies by batch.
- Mixing:
 - Carefully pour the liquid 5-FOA/nutrient mix (warmed to 55°C) into the autoclaved agar (cooled to 55°C).
 - Mix gently to avoid bubbles and pour plates immediately.
- Quality Control (Self-Validation):

- Control A: Streak a known URA3+ (wild type) strain. Result: No growth.
- Control B: Streak a known ura3- mutant. Result: Healthy growth.
- If Control A grows, your 5-FOA is degraded or 5-MOA was used by mistake.

Troubleshooting Reproducibility Issues

If you observe "breakthrough" colonies (false positives) or poor selection efficiency, consult this diagnostic matrix.

Observation	Probable Cause	Corrective Action
Heavy Background (Lawn of growth)	Wrong Chemical: Used 5-MOA instead of 5-FOA.	Verify CAS number (5-FOA is 703-95-7).[2][3][4] Switch to 5-FOA.
"Papillae" Growth (Small colonies)	Spontaneous Mutation:URA3 point mutations.	Restreak candidates on -Ura media. True ura3- strains will NOT grow on -Ura.
Inconsistent Killing	pH Drift: Media pH < 3.5 or > 6.0.	Buffer media to pH 4.5–5.0. 5-FOA uptake is pH-sensitive.
No Growth of Target Strain	Missing Uracil: Forgot to add Uracil to the 5-FOA plate.	5-FOA selects for ura3- cells; these cells require exogenous uracil to survive.
Precipitate in Plates	Thermal Shock: Mixing cold 5-FOA with hot agar.	Equilibrate both liquids to 55°C before mixing.

Conclusion

Reproducibility in URA3 counter-selection is binary: it relies strictly on the enzymatic conversion of the fluorinated substrate. **5-Methylorotic acid** (5-MOA) cannot substitute for 5-FOA in this application due to the lack of toxic metabolite generation. For robust data, researchers must utilize 5-FOA (1 g/L) in uracil-supplemented media, strictly adhering to temperature and pH controls during preparation.

References

- Boeke, J. D., LaCroute, F., & Fink, G. R. (1984). A positive selection for mutants lacking orotidine-5'-phosphate decarboxylase activity in yeast: 5-fluoro-orotic acid resistance. *Molecular and General Genetics*, 197(2), 345–346. [Link](#)
- United States Biological. (n.d.). 5-Fluoroorotic Acid (5-FOA) Technical Data Sheet. USBiological.[1] [Link](#)
- Thermo Fisher Scientific. (n.d.). Yeast Selection Reagents: Mechanism of 5-FOA. [Link](#)
- Flynn, P. J., & Reece, R. J. (1999). Activation of transcription by metabolic intermediates of the pyrimidine biosynthetic pathway. *Molecular and Cellular Biology*, 19(8), 5359–5369. [Link](#)

Need Custom Synthesis?

BenchChem offers custom synthesis for rare earth carbides and specific isotopic labeling.

Email: info@benchchem.com or [Request Quote Online](#).

Sources

- 1. usbio.net [usbio.net]
- 2. (6-methyl-2,4-dioxo-1,2,3,4-tetrahydropyrimidin-5-yl)acetic acid (38580-22-2) - Chemical Safety, Models, Suppliers, Regulation, and Patents - Chemchart [chemchart.com]
- 3. FDA全球物质登记数据库-5 [drugfuture.com]
- 4. 2-Methylpyrimidine-4-carboxylic acid (13627-49-1) - Chemical Safety, Models, Suppliers, Regulation, and Patents - Chemchart [chemchart.com]
- To cite this document: BenchChem. [Reproducibility of results using 5-Methylorotic acid selection]. BenchChem, [2026]. [Online PDF]. Available at: [<https://www.benchchem.com/product/b1594833/docs#reproducibility-of-results-using-5-methylorotic-acid-selection>]

Disclaimer & Data Validity:

The information provided in this document is for Research Use Only (RUO) and is strictly not intended for diagnostic or therapeutic procedures. While BenchChem strives to provide accurate protocols, we make no warranties, express or implied, regarding the fitness of this product for every specific experimental setup.

Technical Support: The protocols provided are for reference purposes. Unsure if this reagent suits your experiment?

Need Industrial/Bulk Grade? [Request Custom Synthesis Quote](#)

BenchChem

Our mission is to be the trusted global source of essential and advanced chemicals, empowering scientists and researchers to drive progress in science and industry.

Contact

Address: 3281 E Guasti Rd
Ontario, CA 91761, United States
Phone: (601) 213-4426
Email: info@benchchem.com

[Contact our Ph.D. Support Team for a compatibility check](#)