

The Synthesis of α -Methylphenethyl Isothiocyanate: A Technical Guide for Researchers

Author: BenchChem Technical Support Team. **Date:** May 2026

Compound of Interest

Compound Name: (2-Isothiocyanatopropyl)benzene

CAS No.: 16220-05-6

Cat. No.: B1593800

[Get Quote](#)

Introduction: The Significance of the Isothiocyanate Moiety

Isothiocyanates (ITCs) are a class of naturally occurring organosulfur compounds characterized by the R-N=C=S functional group. They are renowned for their presence in cruciferous vegetables and are responsible for the pungent flavor of plants like mustard and wasabi.[1] Beyond their sensory characteristics, ITCs have garnered significant attention in the drug development landscape due to their diverse biological activities, including potent anti-cancer, anti-inflammatory, and antimicrobial properties.[2] The electrophilic carbon atom of the isothiocyanate group readily reacts with biological nucleophiles, underpinning its wide range of pharmacological effects.[2]

α -Methylphenethyl isothiocyanate, also known as phentermine isothiocyanate, is a derivative of phentermine, a well-known sympathomimetic amine.[3] The introduction of the isothiocyanate moiety to the phentermine scaffold presents an intriguing avenue for the development of novel therapeutic agents, combining the pharmacological profile of phentermine with the bioactivity of

the isothiocyanate group. This guide provides an in-depth review of the synthetic methodologies for preparing α -methylphenethyl isothiocyanate, with a focus on the underlying chemical principles and practical experimental considerations.

Core Synthetic Strategy: From Primary Amine to Isothiocyanate

The most direct and widely employed strategy for the synthesis of α -methylphenethyl isothiocyanate commences with its primary amine precursor, α -methylphenethylamine (phentermine). The conversion of a primary amine to an isothiocyanate is a cornerstone transformation in organic synthesis. Historically, this was often achieved using the highly toxic and hazardous reagent, thiophosgene (CSCl_2).^[4] However, contemporary synthetic chemistry has largely pivoted towards safer and more environmentally benign alternatives.

The predominant modern approach is a two-step process initiated by the formation of a dithiocarbamate salt, which is subsequently decomposed to yield the desired isothiocyanate. This method offers a significant safety advantage over the use of thiophosgene and its analogs.^[5]

Part 1: The Dithiocarbamate Intermediate Pathway

The reaction of a primary amine with carbon disulfide (CS_2) in the presence of a base is the foundational step in this synthetic route, leading to the formation of a dithiocarbamate salt.^[5] This intermediate is then subjected to a desulfurization reaction to furnish the final isothiocyanate product.

Step 1: Formation of the Dithiocarbamate Salt

The nucleophilic primary amine of phentermine attacks the electrophilic carbon atom of carbon disulfide. A base, such as triethylamine (Et_3N) or an inorganic base like sodium bicarbonate (NaHCO_3), facilitates this reaction by deprotonating the resulting dithiocarbamic acid to form the more stable dithiocarbamate salt.^[6]

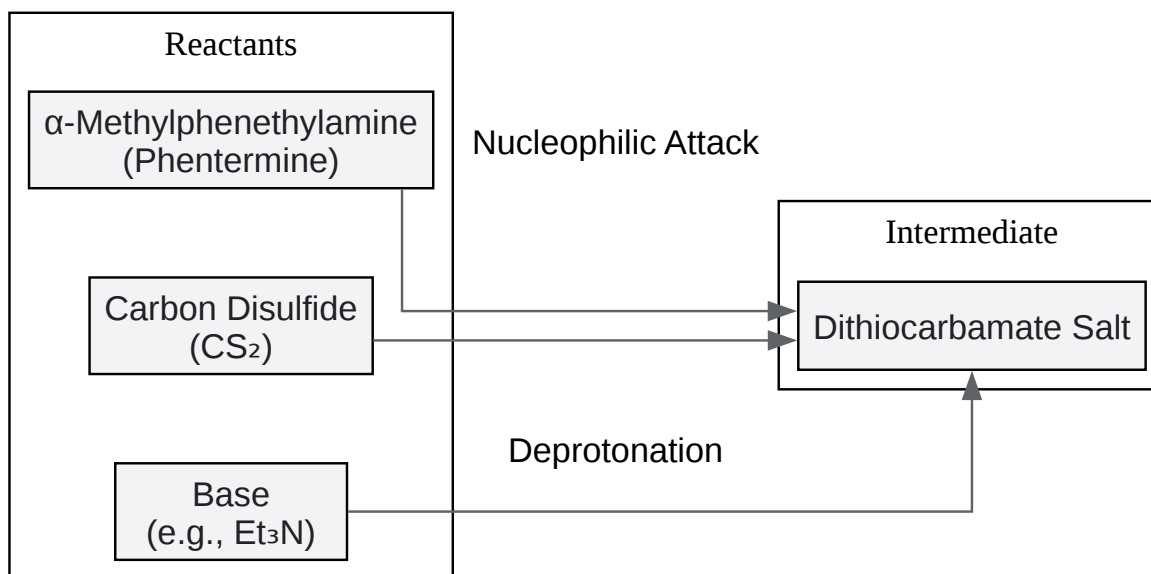

[Click to download full resolution via product page](#)

Caption: Formation of the dithiocarbamate salt from phentermine.

Step 2: Desulfurization of the Dithiocarbamate Salt

The crucial second step involves the elimination of a sulfur atom from the dithiocarbamate intermediate. A variety of desulfurizing agents can be employed, each with its own advantages and disadvantages. The choice of reagent can influence reaction conditions, yield, and the overall "greenness" of the synthesis.

A Comparative Analysis of Desulfurization Reagents

The selection of an appropriate desulfurizing agent is a critical decision in the synthesis of α -methylphenethyl isothiocyanate. The table below provides a comparative overview of common reagents.

Desulfurizing Agent	Key Advantages	Key Disadvantages	Typical Reaction Conditions
Thiophosgene (CSCl ₂) / Triphosgene	High reactivity, often good yields.	Highly toxic, hazardous byproducts.	Requires stringent safety protocols.
Lead Nitrate (Pb(NO ₃) ₂) **	Effective for some substrates.	Toxic heavy metal waste.	Often requires elevated temperatures.
Hydrogen Peroxide (H ₂ O ₂)	"Green" reagent, water is the only byproduct.	Can require careful temperature control.	Aqueous or biphasic systems, mild conditions.[7]
Iodine (I ₂) **	Mild, readily available, and relatively non-toxic.	Can be less effective for electron-deficient amines.	Often used in biphasic systems (e.g., water/ethyl acetate) with a base like NaHCO ₃ . [6]
Tosyl Chloride (TsCl)	Efficient and rapid.	Can generate stoichiometric amounts of salt waste.	Typically in the presence of a tertiary amine base.
Cyanuric Chloride	Effective desulfurization agent.	Can be moisture sensitive.	Often used in a one-pot procedure from the amine.[8]
4-(4,6-dimethoxy-1,3,5-triazin-2-yl)-4-methylmorpholinium toluene-4-sulfonate (DMT/NMM/TsO ⁻)	High yields, applicable to a wide range of substrates.[9]	More complex and expensive reagent.	Can be used in microwave-assisted synthesis.[9]

Recommended Synthetic Protocol: A Greener Approach Using Iodine

Considering the balance of efficiency, safety, and environmental impact, the use of iodine as a desulfurizing agent presents a compelling choice for the synthesis of α -methylphenethyl isothiocyanate. This method is advantageous due to the low toxicity of the reagents and the straightforward workup.[6]

Detailed Step-by-Step Methodology

Materials:

- α -Methylphenethylamine (phentermine)
- Carbon disulfide (CS_2)
- Triethylamine (Et_3N) or Sodium Bicarbonate (NaHCO_3)
- Iodine (I_2)
- Dichloromethane (CH_2Cl_2) or Ethyl Acetate (EtOAc)
- Saturated sodium thiosulfate solution
- Saturated sodium chloride solution (brine)
- Anhydrous magnesium sulfate (MgSO_4) or sodium sulfate (Na_2SO_4)
- Rotary evaporator
- Standard laboratory glassware

Procedure:

- Formation of the Dithiocarbamate Salt (in situ):
 - In a round-bottom flask equipped with a magnetic stir bar, dissolve α -methylphenethylamine (1.0 eq) in dichloromethane or ethyl acetate.
 - Add triethylamine (1.1 eq) or sodium bicarbonate (1.5 eq) to the solution and cool the mixture to 0 °C in an ice bath.

- Slowly add carbon disulfide (1.2 eq) dropwise to the stirred solution.
- Allow the reaction mixture to stir at room temperature for 1-2 hours, or until TLC analysis indicates the complete consumption of the starting amine.
- Desulfurization with Iodine:
 - To the stirred dithiocarbamate salt solution, add a solution of iodine (1.1 eq) in the same solvent dropwise at room temperature. The disappearance of the iodine color may be observed.
 - Continue stirring for an additional 1-3 hours at room temperature. Monitor the reaction progress by TLC.
- Workup and Purification:
 - Upon completion of the reaction, quench the excess iodine by washing the reaction mixture with a saturated solution of sodium thiosulfate until the organic layer is colorless.
 - Separate the organic layer and wash it sequentially with water and brine.
 - Dry the organic layer over anhydrous magnesium sulfate or sodium sulfate, filter, and concentrate the solvent under reduced pressure using a rotary evaporator.
 - The crude α -methylphenethyl isothiocyanate can be purified by vacuum distillation or column chromatography on silica gel if necessary.

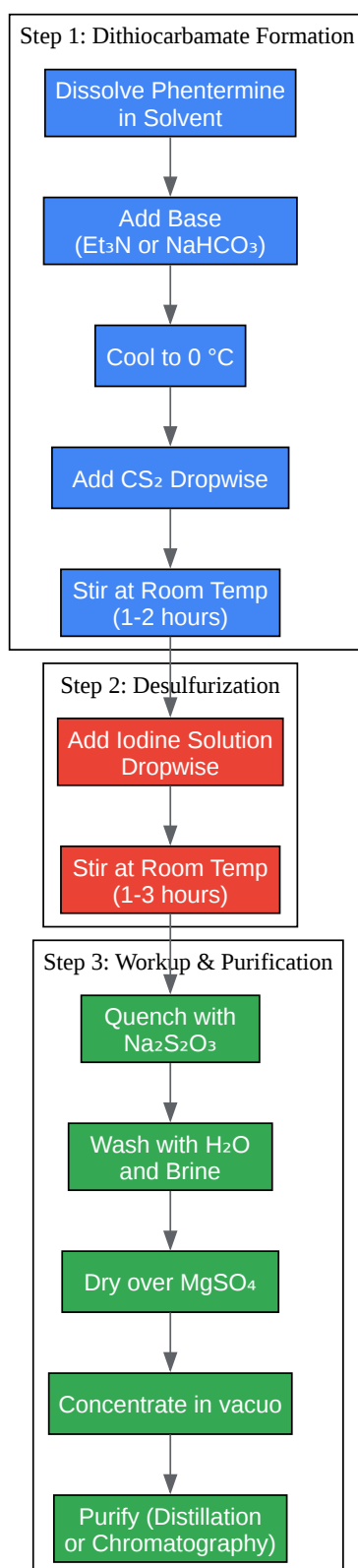

[Click to download full resolution via product page](#)

Caption: Experimental workflow for the synthesis of α -methylphenethyl isothiocyanate.

Physicochemical Properties of α -Methylphenethyl Isothiocyanate

A comprehensive understanding of the physicochemical properties of the target compound is essential for its handling, characterization, and formulation.

Property	Value	Source
Molecular Formula	C ₁₀ H ₁₁ NS	PubChem CID: 85976[10]
Molecular Weight	177.27 g/mol	PubChem CID: 85976[10]
Appearance	Expected to be a colorless to pale yellow liquid.	General observation for similar ITCs.
Boiling Point	Not explicitly reported, but likely >200 °C.	Estimation based on similar structures.
Solubility	Insoluble in water, soluble in common organic solvents.	General property of isothiocyanates.
XLogP3	4	PubChem CID: 85976[10]

Safety Considerations

- **Phentermine:** Phentermine is a controlled substance in many jurisdictions and can have significant cardiovascular and central nervous system effects.[11][12] Handle with appropriate personal protective equipment (PPE) and in accordance with all local regulations.
- **Carbon Disulfide:** CS₂ is highly flammable and toxic. It should be handled in a well-ventilated fume hood.
- **Isothiocyanates:** Isothiocyanates are generally considered to be lachrymators and skin irritants.[10] The final product, α -methylphenethyl isothiocyanate, should be handled with care, using appropriate PPE, including gloves and safety glasses.

Conclusion

The synthesis of α -methylphenethyl isothiocyanate from its primary amine precursor, phentermine, is a readily achievable transformation for researchers in drug discovery and development. While historical methods relied on hazardous reagents, modern approaches, particularly the two-step dithiocarbamate pathway with "greener" desulfurizing agents like iodine, offer a safer and more environmentally conscious route. This guide provides a solid foundation for the successful synthesis and purification of this promising compound, paving the way for further investigation into its biological properties.

References

- Synthesis of Isothiocyanates: A Review. CHEMISTRY & BIOLOGY INTERFACE. (2020-04-30).
- Janczewski, Ł., et al.
- Eschliman, K., & Bossmann, S. H.
- Synthesis method of phentermine hydrochloride.
- Upadhyaya, K., et al. Synthesis of Phentermine and its Derivatives. Current Organic Synthesis. (2023).
- The synthesis and the mechanism of a five-membered ring formation between an isothiocyanate and an amide leading to the yield of Enzalutamide anticancer API; a joint experimental and theoretical study.
- Phenethyl Isothiocyan
- High-purity isothiocyanate compound preparation method for industrial production.
- Janczewski, Ł., et al.
- Amphetamine isothiocyan
- One-Pot Synthesis of Isothiocyanates from Amines Mediated by Carbon Tetrabromide. ChemistrySelect. (2023).
- Process for preparing methyl isothiocyanate by using water phase synthesis method.
- Sharma, S. Thiophosgene in Organic Synthesis.
- Phentermine Interactions Checker. Drugs.com. (n.d.).
- Methyl isothiocyanate (Ref: SN-32866). AERU - University of Hertfordshire. (n.d.).
- Electrochemical isothiocyanation of primary amines. University of Greenwich. (n.d.).
- Phentermine Oral Forms Interactions: Alcohol, Medic
- A general and facile one-pot process of isothiocyanates from amines under aqueous conditions.
- Common Phentermine Drug Interactions to Avoid. GoodRx. (n.d.).
- Li, J., et al. A general and facile one-pot process of isothiocyanates from amines under aqueous conditions. Beilstein Journal of Organic Chemistry. (2012).
- Kala, C., et al. Isothiocyanates: a Review. Research Journal of Pharmacognosy. (2018).

- Methyl Isothiocyanate.
- Phentermine Hydrochloride. (n.d.).
- A One-Pot Approach to Pyridyl Isothiocyanates
- Phentermine oral tablet interactions: A detailed guide. Optum Perks. (n.d.).

Need Custom Synthesis?

BenchChem offers custom synthesis for rare earth carbides and specific isotopic labeling.

Email: info@benchchem.com or [Request Quote Online](#).

Sources

- [1. Phenethyl Isothiocyanate | C₉H₉NS | CID 16741 - PubChem \[pubchem.ncbi.nlm.nih.gov\]](#)
- [2. rjpharmacognosy.ir \[rjpharmacognosy.ir\]](#)
- [3. researchgate.net \[researchgate.net\]](#)
- [4. researchgate.net \[researchgate.net\]](#)
- [5. Thieme E-Journals - Synthesis / Abstract \[thieme-connect.com\]](#)
- [6. cbijournal.com \[cbijournal.com\]](#)
- [7. CN102351766A - Process for preparing methyl isothiocyanate by using water phase synthesis method - Google Patents \[patents.google.com\]](#)
- [8. A general and facile one-pot process of isothiocyanates from amines under aqueous conditions - PMC \[pmc.ncbi.nlm.nih.gov\]](#)
- [9. researchgate.net \[researchgate.net\]](#)
- [10. Amphetamine isothiocyanate | C₁₀H₁₁NS | CID 85976 - PubChem \[pubchem.ncbi.nlm.nih.gov\]](#)
- [11. drugs.com \[drugs.com\]](#)
- [12. Phentermine and Interactions: Supplements, Alcohol, and More \[healthline.com\]](#)
- To cite this document: BenchChem. [The Synthesis of α -Methylphenethyl Isothiocyanate: A Technical Guide for Researchers]. BenchChem, [2026]. [Online PDF]. Available at: [\[https://www.benchchem.com/product/b1593800/docs#the-synthesis-of-methylphenethyl-isothiocyanate-a-technical-guide-for-researchers\]](https://www.benchchem.com/product/b1593800/docs#the-synthesis-of-methylphenethyl-isothiocyanate-a-technical-guide-for-researchers)

Disclaimer & Data Validity:

The information provided in this document is for Research Use Only (RUO) and is strictly not intended for diagnostic or therapeutic procedures. While BenchChem strives to provide accurate protocols, we make no warranties, express or implied, regarding the fitness of this product for every specific experimental setup.

Technical Support: The protocols provided are for reference purposes. Unsure if this reagent suits your experiment?

Need Industrial/Bulk Grade? [Request Custom Synthesis Quote](#)

BenchChem

Our mission is to be the trusted global source of essential and advanced chemicals, empowering scientists and researchers to drive progress in science and industry.

Contact

Address: 3281 E Guasti Rd
Ontario, CA 91761, United States
Phone: (601) 213-4426
Email: info@benchchem.com

[Contact our Ph.D. Support Team for a compatibility check](#)