

# Technical Support Center: Addressing Regioselectivity Problems in Isoxazole Synthesis

**Author:** BenchChem Technical Support Team. **Date:** May 2026

## Compound of Interest

Compound Name:	<i>methyl 5-methyl-3-phenyl-4-isoxazolecarboxylate</i>
CAS No.:	2065-28-3
Cat. No.:	B1593558

[Get Quote](#)

Welcome to the technical support center for isoxazole synthesis. This guide is designed for researchers, medicinal chemists, and process development scientists who are navigating the complexities of controlling regioselectivity in the formation of the isoxazole ring. The isoxazole scaffold is a cornerstone in medicinal chemistry, forming the core of numerous approved drugs. [1] However, its synthesis is often plagued by the formation of regioisomeric mixtures, leading to challenging purifications and reduced yields of the desired product.

This document provides in-depth troubleshooting advice and frequently asked questions to help you diagnose and resolve common issues related to regioselectivity. We will delve into the mechanistic underpinnings of the most common synthetic routes and provide actionable, field-proven protocols to steer your reactions toward the desired isomeric outcome.

## Troubleshooting Guide: Common Regioselectivity Issues & Solutions

This section addresses specific problems you might encounter during your experiments, providing causal explanations and detailed protocols to overcome them.

## Problem 1: My 1,3-dipolar cycloaddition between a nitrile oxide and a terminal alkyne is producing a mixture of 3,4- and 3,5-disubstituted isoxazoles.

Root Cause Analysis:

The Huisgen 1,3-dipolar cycloaddition is a powerful method for isoxazole synthesis, but its regioselectivity with unsymmetrical alkynes is highly sensitive to steric and electronic factors.<sup>[2]</sup><sup>[3]</sup> The reaction proceeds via a concerted [3+2] cycloaddition mechanism.<sup>[3]</sup><sup>[4]</sup> The regiochemical outcome is dictated by the frontier molecular orbital (FMO) interactions between the nitrile oxide (the 1,3-dipole) and the alkyne (the dipolarophile).<sup>[5]</sup> Generally, the reaction is controlled by the interaction between the Highest Occupied Molecular Orbital (HOMO) of one component and the Lowest Unoccupied Molecular Orbital (LUMO) of the other. For many common substrates, this leads to the 3,5-disubstituted isomer as the thermodynamically favored product. However, a mixture often arises when the electronic and steric biases are not strongly directing.

Solutions & Experimental Protocols:

### Solution 1.1: Implement Copper(I) Catalysis to Favor the 3,5-Regioisomer.

Causality: Copper(I) catalysts, particularly in the context of "click chemistry," have been shown to dramatically enhance both the rate and regioselectivity of the reaction between terminal alkynes and in situ generated nitrile oxides, strongly favoring the 3,5-disubstituted product.<sup>[6]</sup><sup>[7]</sup> The mechanism is believed to involve the formation of a copper(I) acetylide intermediate, which then undergoes a stepwise reaction with the nitrile oxide.<sup>[7]</sup>

Protocol: One-Pot Copper(I)-Catalyzed Isoxazole Synthesis (CuAAC variant)<sup>[7]</sup>

- To a stirred solution of the terminal alkyne (1.0 equiv.) and the corresponding aldoxime (1.1 equiv.) in a 1:1 mixture of t-BuOH and water, add sodium ascorbate (0.1 equiv.).

- Add a solution of copper(II) sulfate pentahydrate ( $\text{CuSO}_4 \cdot 5\text{H}_2\text{O}$ , 0.05 equiv.) in a minimum amount of water.
- Add the base (e.g., triethylamine, 1.2 equiv.) to generate the nitrile oxide in situ.
- Stir the reaction at room temperature for 4-12 hours, monitoring by TLC or LC-MS.
- Upon completion, dilute the reaction with water and extract with ethyl acetate. Wash the organic layer with brine, dry over  $\text{Na}_2\text{SO}_4$ , and concentrate in vacuo.
- Purify the crude product by column chromatography on silica gel.

## Solution 1.2: Employ Ruthenium Catalysis to Selectively Form the 3,4-Regioisomer.

Causality: In a complementary fashion to copper, certain ruthenium catalysts can reverse the regioselectivity to favor the formation of 3,4-disubstituted isoxazoles.<sup>[8][9]</sup> This catalyst-controlled regioselectivity switch is a powerful tool when the less common isomer is the target.<sup>[10]</sup> The proposed mechanism involves the formation of a ruthenium-vinylidene complex that directs the cycloaddition.

Protocol: Ruthenium-Catalyzed Synthesis of 3,4-Disubstituted Isoxazoles<sup>[11]</sup>

- In a glovebox, charge a reaction vial with a ruthenium catalyst such as  $[\text{Cp}^*\text{RuCl}(\text{cod})]$  (5 mol%).
- Add the terminal alkyne (1.0 equiv.) and the nitrile oxide precursor (e.g., a hydroximoyl chloride, 1.2 equiv.) in a suitable solvent (e.g., toluene or THF).
- Add a base (e.g., triethylamine, 1.5 equiv.) to generate the nitrile oxide in situ.
- Seal the vial and stir at the optimized temperature (e.g., 60-80 °C) for 12-24 hours. Monitor progress by LC-MS.
- After cooling to room temperature, filter the reaction mixture through a pad of celite and concentrate the filtrate.
- Purify the residue by flash chromatography to isolate the 3,4-disubstituted isoxazole.

## Problem 2: The reaction of my unsymmetrical 1,3-dicarbonyl compound with hydroxylamine yields an inseparable mixture of regioisomers.

### Root Cause Analysis:

The Claisen isoxazole synthesis, which involves the cyclocondensation of a 1,3-dicarbonyl compound with hydroxylamine, is a classic and straightforward method.[1][12] However, when an unsymmetrical 1,3-dicarbonyl is used, two regioisomeric products are possible, arising from the initial condensation of hydroxylamine at either of the two distinct carbonyl carbons.[1] The selectivity is often poor because the reactivity of the two carbonyl groups can be very similar.

### Solutions & Experimental Protocols:

#### Solution 2.1: Modify the Substrate to a $\beta$ -Enamino Diketone for Controlled Cyclization.

Causality: Converting the 1,3-dicarbonyl into a  $\beta$ -enamino diketone introduces a significant electronic difference between the two carbonyl groups. The enamine moiety deactivates the adjacent carbonyl towards nucleophilic attack, thereby directing the initial attack of hydroxylamine to the more electrophilic, unconjugated carbonyl.[1][13] By carefully choosing the reaction conditions (solvent, temperature, and additives), you can achieve high regioselectivity.[1][13][14]

#### Protocol: Regioselective Synthesis from a $\beta$ -Enamino Diketone[13]

- Synthesize the  $\beta$ -enamino diketone from the corresponding 1,3-dicarbonyl and a secondary amine (e.g., pyrrolidine or morpholine).
- Dissolve the  $\beta$ -enamino diketone (1.0 equiv.) and hydroxylamine hydrochloride (1.2 equiv.) in a selected solvent (e.g., ethanol, acetonitrile, or acetic acid).
- To favor one regioisomer: Conduct the reaction in ethanol at reflux.
- To favor the alternative regioisomer: Add a Lewis acid like  $\text{BF}_3 \cdot \text{OEt}_2$  (2.0 equiv.) and pyridine (1.4 equiv.) in acetonitrile at room temperature.[13][14]

- Monitor the reaction by TLC. The reaction times can vary from 2 to 24 hours.
- After completion, neutralize the reaction mixture (if acidic) and perform a standard aqueous workup.
- Purify the product via column chromatography or recrystallization.

Condition	Solvent	Additive	Predominant Regioisomer	Reference
Method A	Ethanol	None (or mild base)	4,5-disubstituted	[13]
Method B	Acetonitrile	BF <sub>3</sub> ·OEt <sub>2</sub> , Pyridine	3,4-disubstituted	[13][14]
Method C	Acetic Acid	None	3,5-disubstituted	[1]

Table 1: Influence of Reaction Conditions on Regioselectivity in the Cyclocondensation of  $\beta$ -Enamino Diketones with Hydroxylamine.

## Frequently Asked Questions (FAQs)

Q1: What are the primary factors that control regioselectivity in the 1,3-dipolar cycloaddition for isoxazole synthesis?

A1: Regioselectivity in the Huisgen cycloaddition is primarily governed by a combination of electronic and steric effects.[2][3]

- **Electronic Effects:** These are best understood using Frontier Molecular Orbital (FMO) theory. [5] The reaction is controlled by the energy gap between the HOMO of the nitrile oxide and the LUMO of the alkyne (or vice-versa). The larger orbital coefficients on the interacting atoms will preferentially form the new sigma bonds, thus dictating the orientation (regiochemistry) of the addition.
- **Steric Effects:** Bulky substituents on either the nitrile oxide or the alkyne will sterically hinder one of the two possible transition states, favoring the approach that minimizes steric

repulsion.[15] In many cases, this favors the formation of the 3,5-disubstituted isoxazole where the bulky groups are further apart.

- Catalysis: As detailed in the troubleshooting guide, the choice of metal catalyst (e.g., Copper vs. Ruthenium) can override the intrinsic electronic and steric preferences of the substrates to yield a specific regioisomer.[8][16]

Q2: How can I reliably determine the regiochemistry of my synthesized isoxazoles?

A2: Unambiguous structural assignment is critical. A combination of spectroscopic techniques is the most robust approach.

- NMR Spectroscopy: This is the most powerful tool.
  - $^1\text{H}$ - $^{13}\text{C}$  HMBC/HSQC: Heteronuclear Multiple Bond Correlation (HMBC) is particularly useful. For a 3,5-disubstituted isoxazole, you will observe a 3-bond correlation ( $^3\text{J}$ ) between the proton at C4 and the carbon of the substituent at C5, and also between the C4 proton and the carbon of the substituent at C3. For a 3,4-disubstituted isomer, correlations will be observed differently.[17]
  - NOE (Nuclear Overhauser Effect): NOE experiments can show through-space proximity between the protons on the substituents and the remaining proton on the isoxazole ring (e.g., H4), helping to confirm their relative positions.
  - $^{13}\text{C}\{^{14}\text{N}\}$  Solid-State NMR: Specialized techniques can function as an "attached nitrogen test," allowing for straightforward differentiation by identifying carbons directly bonded to nitrogen.[18][19]
- Single-Crystal X-ray Diffraction: If you can obtain a suitable crystal, this method provides definitive, unambiguous proof of the molecular structure and regiochemistry.

Q3: My nitrile oxide precursor seems to be decomposing or dimerizing, leading to low yields. How can I mitigate this?

A3: Nitrile oxides are unstable and prone to dimerization to form furoxans.[20] The best strategy is to generate the nitrile oxide in situ at a controlled rate, so its concentration remains low and it is consumed by the alkyne as it is formed.

- **Slow Addition of Base:** When generating the nitrile oxide from a hydroximoyl chloride, add the base (e.g., triethylamine) slowly to the reaction mixture containing the alkyne.
- **Choice of Generation Method:** The classic method involves dehydrohalogenation of a hydroximoyl chloride with a base. Alternatively, oxidation of an aldoxime (e.g., with chloramine-T, N-chlorosuccinimide (NCS), or (hydroxy(tosyloxy)iodo)benzene (HTIB)) is a very common and effective method.[6][20] These conditions are often compatible with one-pot catalytic cycloadditions.

## Visualizing the Regiochemical Challenge

The diagrams below illustrate the two primary synthetic pathways and the regiochemical choice inherent in each.

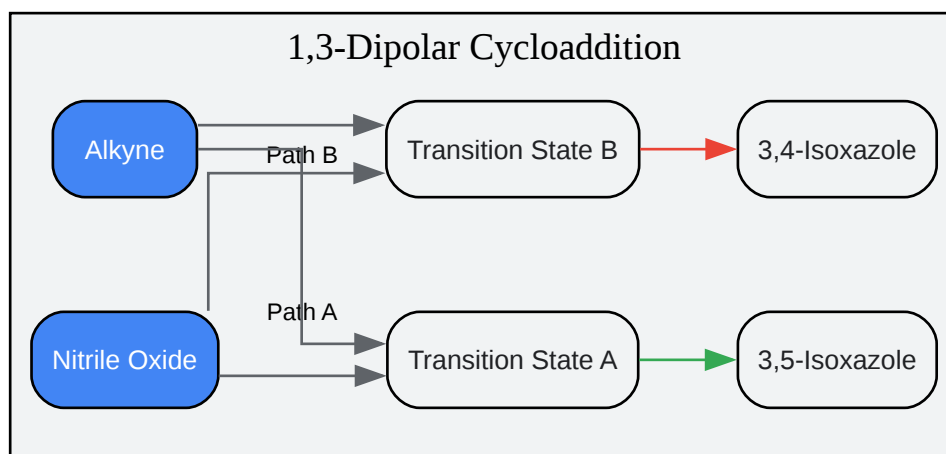

[Click to download full resolution via product page](#)

Caption: Regiochemical divergence in 1,3-dipolar cycloaddition.

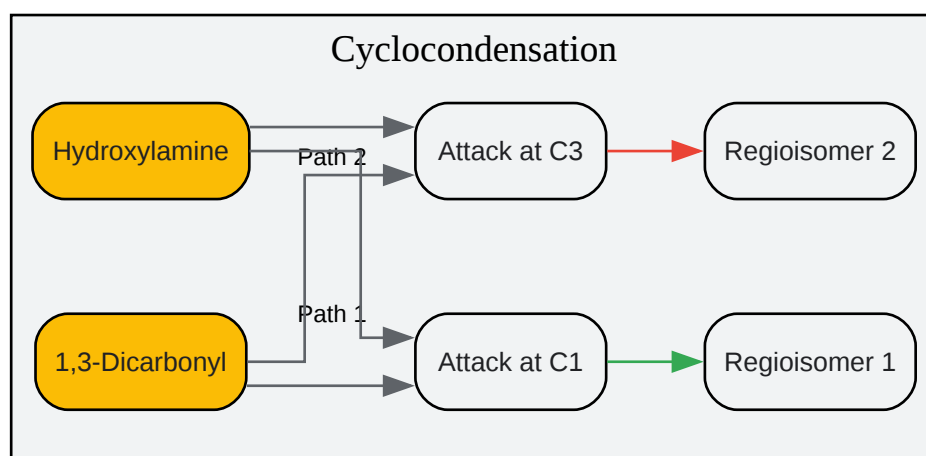

[Click to download full resolution via product page](#)

Caption: Regiochemical outcomes in Claisen isoxazole synthesis.

## References

- Houk, K. N., et al. (2016). Origins of regioselectivity in 1,3-dipolar cycloadditions of nitrile oxides with alkynylboronates. *Bioorganic & Medicinal Chemistry*, 24(20), 4787-4790.
- Ahmed, N., et al. (2023). Synthesis of isoxazole derivatives by 1,3-DC of NOs and alkynes... ResearchGate. Available at: [\[Link\]](#)
- Silva, R. G. M., et al. (2018). Development of methodologies for the regioselective synthesis of four series of regioisomer isoxazoles from  $\beta$ -enamino diketones. *RSC Advances*, 8(10), 5188-5199. Available at: [\[Link\]](#)
- Hernandez, J. G., et al. (2020). Regioselective control under mechanochemical conditions for 3,4,5-isoxazoles. ResearchGate. Available at: [\[Link\]](#)
- Wikipedia. (n.d.). 1,3-Dipolar cycloaddition. Wikipedia. Available at: [\[Link\]](#)
- Ross, A. G., & Windus, T. L. (2018). Attached Nitrogen Test by  $^{13}\text{C}$ - $^{14}\text{N}$  Solid-State NMR Spectroscopy for the Structure Determination of Heterocyclic Isomers. *Chemistry – A European Journal*, 24(56), 14945-14949. Available at: [\[Link\]](#)
- Reja, R. M., Sunny, S., & Gopi, H. N. (2017). Chemoselective Nitrile Oxide–Alkyne 1,3-Dipolar Cycloaddition Reactions from Nitroalkane-Tethered Peptides. *Organic Letters*,

19(13), 3652-3655. Available at: [\[Link\]](#)

- Kaur, R., et al. (2018). The synthetic and therapeutic expedition of isoxazole and its analogs. *Medicinal Chemistry Research*, 27(1), 1-28. Available at: [\[Link\]](#)
- Hansen, T. V., Wu, P., & Fokin, V. V. (2005). One-Pot Copper(I)-Catalyzed Synthesis of 3,5-Disubstituted Isoxazoles. *The Journal of Organic Chemistry*, 70(19), 7761-7764. Available at: [\[Link\]](#)
- Silva, R. G. M., et al. (2018). Development of methodologies for the regioselective synthesis of four series of regioisomer isoxazoles from  $\beta$ -enamino diketones. *RSC Advances*, 8(10), 5188-5199. Available at: [\[Link\]](#)
- Chem Vids. (2019). Synthesis of Isoxazoles. YouTube. Available at: [\[Link\]](#)
- Silva, R. G. M., et al. (2018). Development of methodologies for the regioselective synthesis of four series of regioisomer isoxazoles from  $\beta$ -enamino diketones. RSC Publishing. Available at: [\[Link\]](#)
- ResearchGate. (n.d.). 1,3-dipolar cycloaddition reaction of nitrile oxides and alkyne. ResearchGate. Available at: [\[Link\]](#)
- da Silva, A. C. M., et al. (2020). A Convenient Synthesis of Novel Isoxazolidine and Isoxazole Isoquinolinones Fused Hybrids. *Molecules*, 25(18), 4296. Available at: [\[Link\]](#)
- Ross, A. G., & Windus, T. L. (2018). Attached Nitrogen Test by  $^{13}\text{C}$ - $^{14}\text{N}$  Solid-State NMR Spectroscopy for the Structure Determination of Heterocyclic Isomers. *Chemistry – A European Journal*, 24(56), 14945-14949. Available at: [\[Link\]](#)
- A review of isoxazole biological activity and present synthetic techniques. (2022). *World Journal of Advanced Research and Reviews*. Available at: [\[Link\]](#)
- Abdessadak, O., et al. (2024). Chemical reactivity and regioselectivity investigation for the formation of 3,5-disubstituted isoxazole via cycloaddition [2 + 3] and antitrypanosomal activity prediction. *Computational and Theoretical Chemistry*, 1233, 114478. Available at: [\[Link\]](#)

- Request PDF. (2025). Chemical Reactivity and regioselectivity investigation for the formation of 3,5-disubstituted isoxazole via cycloaddition [2+3] and antitrypanosomal activity prediction. ResearchGate. Available at: [\[Link\]](#)
- Catalyst-controlled switch of regioselectivity in the asymmetric allylic alkylation of oxazolones with MBHCs. (2021). Chemical Communications. Available at: [\[Link\]](#)
- The Green and Effective Synthesis of Isoxazole-Based Molecules Under Ultrasonic Irradiation Approaches. (2024). MDPI. Available at: [\[Link\]](#)
- An overview of metal-free synthetic routes to isoxazoles: the privileged scaffold. (2021). RSC Advances. Available at: [\[Link\]](#)
- Huisgen 1,3-Dipolar Cycloaddition. (n.d.). Organic Chemistry Portal. Available at: [\[Link\]](#)
- Regioselective synthesis of isoxazole and 1,2,4-oxadiazole-derived phosphonates via [3 + 2] cycloaddition. (2013). Organic & Biomolecular Chemistry. Available at: [\[Link\]](#)
- Advanced NMR techniques for structural characterization of heterocyclic structures. (n.d.). ESA-IPB. Available at: [\[Link\]](#)
- Computational Study of Transition States Selectivity, Solvent Effects, and Bicyclo Formation The 1,3-Dipolar Cycloaddition of Nitrile Oxide to Vinylacetic Acid. (2016). SciELO. Available at: [\[Link\]](#)
- Chemical reactivity and regioselectivity investigation for the formation of 3,5-disubstituted isoxazole via cycloaddition [2 + 3] and antitrypanosomal activity prediction. (2024). R Discovery. Available at: [\[Link\]](#)
- Utilizing benchtop NMR spectroscopy to identify regioisomers in pharmaceutical compounds. (2024). AZoM.com. Available at: [\[Link\]](#)
- NMR SPECTROSCOPY OF HETEROCYCLES: SUBSTITUENT EFFECTS IN 3,5-DIARYL-ISOXAZOLES AND 3,5-DIARYLISOXAZOLINES. (n.d.). Magnetic Resonance in Chemistry. Available at: [\[Link\]](#)

- Synthesis of a Novel Tetracyclic Isoxazole by Intramolecular Nitrile Oxide Cycloaddition. (2022). MDPI. Available at: [\[Link\]](#)
- The Synthesis of Highly Substituted Isoxazoles by Electrophilic Cyclization. An Efficient Synthesis of Valdecoxib. (2007). Journal of Organic Chemistry. Available at: [\[Link\]](#)
- Advances in isoxazole chemistry and their role in drug discovery. (2025). RSC Advances. Available at: [\[Link\]](#)
- Structure-Activity Relationship Studies of Trisubstituted Isoxazoles as Selective Allosteric Ligands for the Retinoid-Related Orphan Receptor  $\gamma$ t (ROR $\gamma$ t). (2021). Journal of Medicinal Chemistry. Available at: [\[Link\]](#)

### Need Custom Synthesis?

BenchChem offers custom synthesis for rare earth carbides and specific isotopic labeling.

Email: [info@benchchem.com](mailto:info@benchchem.com) or [Request Quote Online](#).

## Sources

- 1. Development of methodologies for the regioselective synthesis of four series of regioisomer isoxazoles from  $\beta$ -enamino diketones - RSC Advances (RSC Publishing) DOI:10.1039/C7RA13343J [[pubs.rsc.org](https://pubs.rsc.org)]
- 2. Origins of regioselectivity in 1,3-dipolar cycloadditions of nitrile oxides with alkynylboronates - PubMed [[pubmed.ncbi.nlm.nih.gov](https://pubmed.ncbi.nlm.nih.gov)]
- 3. 1,3-Dipolar cycloaddition - Wikipedia [[en.wikipedia.org](https://en.wikipedia.org)]
- 4. Huisgen 1,3-Dipolar Cycloaddition [[organic-chemistry.org](https://organic-chemistry.org)]
- 5. [scielo.br](https://scielo.br) [[scielo.br](https://scielo.br)]
- 6. The synthetic and therapeutic expedition of isoxazole and its analogs - PMC [[pmc.ncbi.nlm.nih.gov](https://pmc.ncbi.nlm.nih.gov)]
- 7. Isoxazole synthesis [[organic-chemistry.org](https://organic-chemistry.org)]
- 8. [benchchem.com](https://benchchem.com) [[benchchem.com](https://benchchem.com)]
- 9. An overview of metal-free synthetic routes to isoxazoles: the privileged scaffold - RSC Advances (RSC Publishing) DOI:10.1039/D1RA04624A [[pubs.rsc.org](https://pubs.rsc.org)]

- 10. Catalyst-controlled switch of regioselectivity in the asymmetric allylic alkylation of oxazolones with MBHCs - Chemical Communications (RSC Publishing) [[pubs.rsc.org](https://pubs.rsc.org)]
- 11. [mdpi.com](https://mdpi.com) [[mdpi.com](https://mdpi.com)]
- 12. [youtube.com](https://youtube.com) [[youtube.com](https://youtube.com)]
- 13. Development of methodologies for the regioselective synthesis of four series of regioisomer isoxazoles from  $\beta$ -enamino diketones - PMC [[pmc.ncbi.nlm.nih.gov](https://pubmed.ncbi.nlm.nih.gov)]
- 14. [pubs.rsc.org](https://pubs.rsc.org) [[pubs.rsc.org](https://pubs.rsc.org)]
- 15. The Synthesis of Highly Substituted Isoxazoles by Electrophilic Cyclization. An Efficient Synthesis of Valdecixib - PMC [[pmc.ncbi.nlm.nih.gov](https://pubmed.ncbi.nlm.nih.gov)]
- 16. [benchchem.com](https://benchchem.com) [[benchchem.com](https://benchchem.com)]
- 17. [news-medical.net](https://news-medical.net) [[news-medical.net](https://news-medical.net)]
- 18. DSpace [[dr.lib.iastate.edu](https://dr.lib.iastate.edu)]
- 19. Attached Nitrogen Test by  $^{13}\text{C}$ - $^{14}\text{N}$  Solid-State NMR Spectroscopy for the Structure Determination of Heterocyclic Isomers - PMC [[pmc.ncbi.nlm.nih.gov](https://pubmed.ncbi.nlm.nih.gov)]
- 20. [researchgate.net](https://researchgate.net) [[researchgate.net](https://researchgate.net)]
- To cite this document: BenchChem. [Technical Support Center: Addressing Regioselectivity Problems in Isoxazole Synthesis]. BenchChem, [2026]. [Online PDF]. Available at: [<https://www.benchchem.com/product/b1593558/docs#technical-support-center-addressing-regioselectivity-problems-in-isoxazole-synthesis>]

---

### Disclaimer & Data Validity:

The information provided in this document is for Research Use Only (RUO) and is strictly not intended for diagnostic or therapeutic procedures. While BenchChem strives to provide accurate protocols, we make no warranties, express or implied, regarding the fitness of this product for every specific experimental setup.

**Technical Support:** The protocols provided are for reference purposes. Unsure if this reagent suits your experiment?

**Need Industrial/Bulk Grade?** [Request Custom Synthesis Quote](#)

# BenchChem

Our mission is to be the trusted global source of essential and advanced chemicals, empowering scientists and researchers to drive progress in science and industry.

## Contact

Address: 3281 E Guasti Rd

Ontario, CA 91761, United States

Phone: (601) 213-4426

Email: [info@benchchem.com](mailto:info@benchchem.com)

[Contact our Ph.D. Support Team for a compatibility check](#)