

# Benchmarking the Efficiency of DPA Derivatives in Deep-Blue OLEDs: A Comparative Guide

**Author:** BenchChem Technical Support Team. **Date:** May 2026

## Compound of Interest

Compound Name: (9,10-Diphenylanthracen-2-yl)boronic acid  
CAS No.: 597553-98-5  
Cat. No.: B1593163

[Get Quote](#)

The quest for stable and efficient deep-blue organic light-emitting diodes (OLEDs) remains a critical challenge in display and lighting technology. Achieving the deep-blue emission necessary for wide color gamut displays, such as those compliant with the Rec. 2020 standard, without compromising on efficiency or operational lifetime is a key area of research.[1][2][3] Among the various classes of materials being investigated, diphenylamine (DPA) derivatives have emerged as promising candidates due to their unique photophysical properties and tunable molecular structures.[4][5] This guide provides a comprehensive comparison of the performance of various DPA derivatives as emitters in deep-blue OLEDs, supported by experimental data and protocols to aid researchers in this dynamic field.

## The Significance of Deep-Blue Emitters and the Role of DPA Derivatives

Deep-blue OLEDs are essential for achieving a wide color gamut in next-generation displays. However, developing materials that emit in the deep-blue region (with CIEy coordinates less than 0.1) while maintaining high external quantum efficiency (EQE) and stability has proven

difficult.[1] Many traditional blue emitters suffer from issues like low efficiency, poor color purity, and short operational lifetimes.[6]

Diphenylamine (DPA) derivatives have garnered significant attention as a versatile platform for designing high-performance blue emitters. The DPA core can function as an effective electron donor, and by modifying its structure with various acceptor units, the emission color and efficiency can be precisely tuned.[4][5] This donor-acceptor (D-A) architecture is a cornerstone of modern emitter design, particularly for thermally activated delayed fluorescence (TADF) materials, which can theoretically achieve 100% internal quantum efficiency by harvesting both singlet and triplet excitons.[2][3][6]

## Comparative Performance of DPA Derivatives in Deep-Blue OLEDs

The efficiency of DPA derivatives in deep-blue OLEDs is evaluated based on several key performance metrics, including External Quantum Efficiency (EQE), Commission Internationale de l'Éclairage (CIE) coordinates, and emission wavelength ( $\lambda_{EL}$ ). The following table summarizes the performance of several recently developed DPA-based emitters.

| Emitter Codename/<br>Structure | Host Material | Max EQE (%) | CIE Coordinates (x, y) | Emission Peak (nm)         | Reference |
|--------------------------------|---------------|-------------|------------------------|----------------------------|-----------|
| TDBA-DI                        | -             | 38.15       | -                      | Blue region                | [7]       |
| TDBA-Ac                        | -             | 21.50       | (0.15, 0.06)           | Deep-blue                  | [7]       |
| v-DABNA                        | -             | ~34         | -                      | 457 (narrow FWHM of 18 nm) | [2][8]    |
| o-Tol-v-DABNA-Me               | DBFPO         | 33.1        | (y=0.12)               | Deep-blue (FWHM of 18 nm)  | [9]       |
| TDBA-SAF                       | -             | 28.2        | (0.142, 0.090)         | Deep-blue                  | [10]      |
| DBA-SAB                        | -             | 25.7        | (0.144, 0.212)         | Blue                       | [10]      |
| TDBA-Cz                        | mCP           | 6.45        | (0.167, 0.086)         | 413                        | [11]      |
| ICz-An-PPI                     | -             | >7.5        | -                      | -                          | [7]       |
| IP-An-PPI                      | -             | >7.5        | -                      | -                          | [7]       |
| DPA-BO                         | DPEPO         | -           | -                      | -                          | [12]      |
| 3DPA-DiKTa                     | mCP           | -           | -                      | Green                      | [13]      |

#### Analysis of Performance Data:

The data clearly indicates that significant progress has been made in boosting the efficiency of DPA derivatives for deep-blue OLEDs. Notably, materials like TDBA-DI and v-DABNA have demonstrated exceptionally high EQEs, pushing the boundaries of what is achievable with fluorescent and TADF emitters.[2][7][8] The narrow full-width at half-maximum (FWHM) of emitters like v-DABNA is particularly important for achieving high color purity in displays.[8]

The choice of host material also plays a crucial role in device performance. For instance, the performance of o-Tol-v-DABNA-Me was evaluated in a DBFPO host, highlighting the importance of host-guest energy level alignment for efficient energy transfer.[9] Solution-processed devices, as demonstrated with TDBA-Cz, offer a pathway to lower-cost fabrication, although their efficiencies are currently lower than their vacuum-deposited counterparts.[11]

## Experimental Section: Fabrication and Characterization of DPA-based OLEDs

To provide a practical context for the data presented, this section outlines a general, step-by-step protocol for the fabrication and characterization of a DPA-derivative-based deep-blue OLED.

### I. Device Fabrication Workflow

The fabrication of an OLED is a multi-step process typically carried out in a high-vacuum environment to prevent contamination.

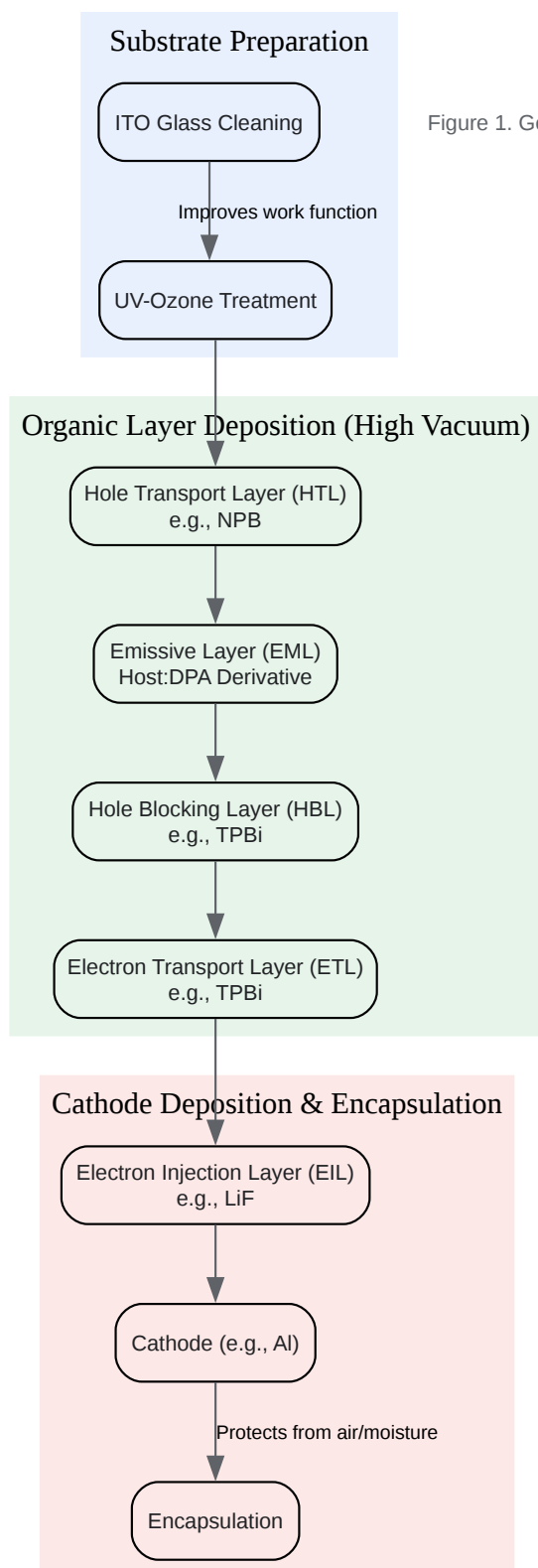
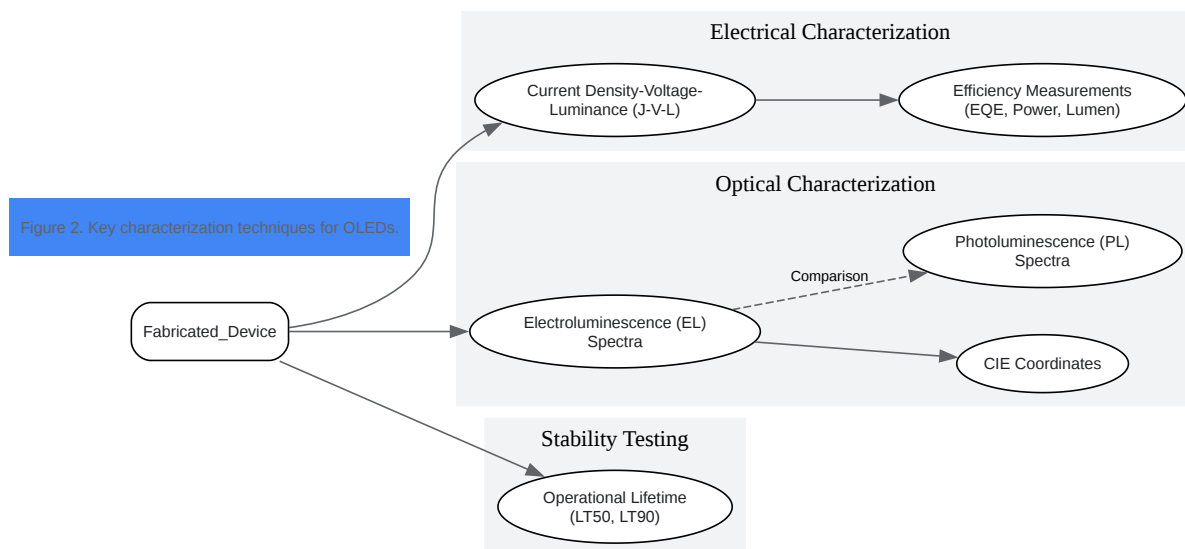

Figure 1. General workflow for OLED fabrication.



[Click to download full resolution via product page](#)

Caption: Figure 2. Key characterization techniques for OLEDs.

#### Key Characterization Techniques:

- **Electrical and Luminance Properties:** The current density-voltage-luminance (J-V-L) characteristics are measured using a source meter and a photometer. From this data, the external quantum efficiency (EQE), power efficiency, and luminous efficiency can be calculated. [14]\*
- **Optical Properties:** The electroluminescence (EL) spectra and Commission Internationale de l'Éclairage (CIE) coordinates are measured using a spectroradiometer. [14] Photoluminescence (PL) spectra of the emitter in solution and thin films are also measured to understand its intrinsic photophysical properties. [15]\*
- **Operational Stability:** The operational lifetime of the device is tested by applying a constant current density and monitoring the luminance over time. The lifetime is often reported as LT50 or LT90, the time it takes for the luminance to decrease to 50% or 90% of its initial value, respectively.

# Causality Behind Experimental Choices and Self-Validation

The choice of materials and device architecture is critical for achieving high-performance deep-blue OLEDs.

- **Energy Level Alignment:** The highest occupied molecular orbital (HOMO) and lowest unoccupied molecular orbital (LUMO) energy levels of the different layers must be carefully chosen to ensure efficient charge injection, transport, and recombination within the emissive layer. [16] For example, the HOMO of the HTL should be close to the work function of the anode (ITO), and the LUMO of the ETL should be close to the work function of the cathode.
- **Host-Guest System:** The host material in the EML should have a higher triplet energy than the guest (DPA derivative) to confine excitons on the guest molecules and prevent energy loss.
- **Thermally Activated Delayed Fluorescence (TADF):** For TADF emitters, the energy gap between the lowest singlet ( $S_1$ ) and triplet ( $T_1$ ) excited states ( $\Delta E_{ST}$ ) must be small enough to allow for efficient reverse intersystem crossing (rISC) from the triplet to the singlet state. [6] This is a key design principle for many high-efficiency DPA derivatives.
- **Molecular Rigidity:** Rigid molecular structures can help to reduce non-radiative decay pathways, leading to higher photoluminescence quantum yields (PLQY) and improved device efficiency and stability. [10] Each experimental step is part of a self-validating system. For instance, the comparison of PL and EL spectra can reveal information about the stability of the emitter during device operation and whether any exciplex formation is occurring at the interfaces between layers. [16][17] The J-V-L characteristics provide immediate feedback on the charge injection and transport properties of the device architecture.

## Future Outlook

The field of deep-blue OLEDs is rapidly advancing, with DPA derivatives at the forefront of this progress. Future research will likely focus on:

- **Novel Molecular Designs:** Synthesizing new DPA derivatives with even smaller  $\Delta E_{ST}$  values and higher PLQY.

- **Advanced Device Architectures:** Exploring new host materials and device structures to further enhance efficiency and stability.
- **Solution-Processable Materials:** Developing high-performance DPA derivatives that are compatible with low-cost, large-area solution-based manufacturing processes. [11][18]\*
- **Improving Operational Lifetime:** A major focus remains on extending the operational stability of deep-blue OLEDs to meet the demands of commercial applications.

By continuing to innovate in these areas, researchers can unlock the full potential of DPA derivatives and pave the way for the next generation of high-performance, energy-efficient displays and lighting.

## References

- MDPI. (n.d.). Thermally Activated Delayed Fluorescence Emitters for Deep Blue Organic Light Emitting Diodes: A Review of Recent Advances. Retrieved from [\[Link\]](#)
- Edinburgh Instruments. (2024, March 22). Enhanced Characterization of OLED Optoelectronic Properties Using Confocal Microscopy. Retrieved from [\[Link\]](#)
- OLED-Info. (2025, October 31). Researchers replaced one molecule in an MR-TADF emitter to create the highest-performance emitter to date. Retrieved from [\[Link\]](#)
- ResearchGate. (n.d.). Breaking the Efficiency Limit of Deep-Blue Fluorescent OLEDs Based on Anthracene Derivatives | Request PDF. Retrieved from [\[Link\]](#)
- National Center for Biotechnology Information. (n.d.). Recent Advancement in Boron-Based Efficient and Pure Blue Thermally Activated Delayed Fluorescence Materials for Organic Light-Emitting Diodes. Retrieved from [\[Link\]](#)
- National Center for Biotechnology Information. (2023, July 13). Facile synthesis of 2-aza-9,10-diphenylanthracene and the effect of precise nitrogen atom incorporation on OLED emitters performance. Retrieved from [\[Link\]](#)
- Royal Society of Chemistry. (n.d.). Recent advances in highly efficient small-molecule TADF emitters for solution-processed OLEDs - Journal of Materials Chemistry C. Retrieved from [\[Link\]](#)

- Ametek. (n.d.). Electrical Characterization of OLED's Using Solartron Instrumentation. Retrieved from [[Link](#)]
- ResearchGate. (2015, February 23). New Methods for Optical Characterization of OLED Displays. Retrieved from [[Link](#)]
- National Center for Biotechnology Information. (2025, January 22). Advancing efficiency in deep-blue OLEDs: Exploring a machine learning–driven multiresonance TADF molecular design. Retrieved from [[Link](#)]
- Tailor Pixels. (n.d.). How to evaluate the performance of OLED?. Retrieved from [[Link](#)]
- ResearchGate. (n.d.). (a) Chemical structures, photophysical and OLED data of reported MR-TADF materials containing DPA units. Retrieved from [[Link](#)]
- ResearchGate. (2023, July 12). (PDF) Facile Synthesis of 2-Aza-9,10-diphenylanthracene and the Effect of Precise Nitrogen Atom Incorporation on OLED Emitters Performance. Retrieved from [[Link](#)]
- IS&T | Library. (n.d.). The characterization of an HDR OLED display. Retrieved from [[Link](#)]
- ResearchGate. (n.d.). Solution-Processed OLEDs Based on a Bipolar AIE Terpyridine Derivative as a Host | Request PDF. Retrieved from [[Link](#)]
- ResearchGate. (n.d.). Enhancing operational stability of OLEDs based on subatomic modified thermally activated delayed fluorescence compounds. Retrieved from [[Link](#)]
- National Center for Biotechnology Information. (n.d.). Highly Efficient Deep-Blue OLEDs using a TADF Emitter with a Narrow Emission Spectrum and High Horizontal Emitting Dipole Ratio. Retrieved from [[Link](#)]
- MDPI. (2024, October 11). Original Blue Light-Emitting Diphenyl Sulfone Derivatives as Potential TADF Emitters for OLEDs. Retrieved from [[Link](#)]
- MDPI. (2023, April 17). Deep-Blue Organic Light-Emitting Diodes Employed Traditional Hole Transporting Material as Emitter for 31-Inch 4K Flexible Display. Retrieved from [[Link](#)]

- ResearchGate. (n.d.). Comparison of external quantum efficiencies (EQE%) for reported.... Retrieved from [[Link](#)]
- ResearchGate. (2025, August 6). Dianthranide derivative for efficient deep blue-emitting organic electroluminescence devices | Request PDF. Retrieved from [[Link](#)]
- MDPI. (n.d.). High-Efficiency Deep-Blue Solution-Processed OLED Devices Enabled by New Dopant Materials. Retrieved from [[Link](#)]
- MDPI. (2024, September 13). Advances in High-Efficiency Blue OLED Materials. Retrieved from [[Link](#)]
- ResearchGate. (n.d.). Deep-Blue OLEDs Based on Organoboron–Phenazasiline-Hybrid Delayed Fluorescence Emitters Concurrently Achieving 30% External Quantum Efficiency and Small Efficiency Roll-Off | Request PDF. Retrieved from [[Link](#)]
- Scilit. (n.d.). Advances in High-Efficiency Blue OLED Materials. Retrieved from [[Link](#)]
- ResearchGate. (2025, August 6). (PDF) Synthesis of DPA-714. Retrieved from [[Link](#)]
- ResearchGate. (2025, October 10). (PDF) High-Efficiency Deep-Blue Solution-Processed OLED Devices Enabled by New Dopant Materials. Retrieved from [[Link](#)]
- National Center for Biotechnology Information. (2017, March 22). Highly Efficient Long-Wavelength Thermally Activated Delayed Fluorescence OLEDs Based on Dicyanopyrazino Phenanthrene Derivatives. Retrieved from [[Link](#)]
- National Center for Biotechnology Information. (2023, May 31). Toward highly efficient deep-blue OLEDs: Tailoring the multiresonance-induced TADF molecules for suppressed excimer formation and near-unity horizontal dipole ratio. Retrieved from [[Link](#)]
- Royal Society of Chemistry. (n.d.). Photophysical properties and OLED performance of light-emitting platinum(ii) complexes - Dalton Transactions. Retrieved from [[Link](#)]
- IIP Series. (n.d.). PROCESS OF DEVELOPING IN ORGANIC LIGHT EMITTING DIODE (OLEDs). Retrieved from [[Link](#)]

- ChemRxiv. (n.d.). Realizing efficient blue and deep-blue delayed fluorescence materials with record-beating electroluminescence efficiencies of 43. Retrieved from [\[Link\]](#)
- ResearchGate. (n.d.). (PDF) TADF Host Engineering for Improved Pure Blue Matrix-Free Hyperfluorescent OLEDs with Ultranarrow Emission. Retrieved from [\[Link\]](#)
- ResearchGate. (2025, August 10). Blue emitting materials based on diphenylamine-substituted diphenylvinylarenes for OLEDs | Request PDF. Retrieved from [\[Link\]](#)
- ResearchGate. (n.d.). Constructing Highly Efficient Blue OLEDs with External Quantum Efficiencies up to 7.5 % Based on Anthracene Derivatives | Request PDF. Retrieved from [\[Link\]](#)
- ACS Publications. (2019, July 17). Molecular Design Strategies for Color Tuning of Blue TADF Emitters. Retrieved from [\[Link\]](#)
- ResearchGate. (2023, June 1). Toward highly efficient deep-blue OLEDs: Tailoring the multiresonance-induced TADF molecules for suppressed excimer formation and near-unity horizontal dipole ratio. Retrieved from [\[Link\]](#)

### Need Custom Synthesis?

BenchChem offers custom synthesis for rare earth carbides and specific isotopic labeling.

Email: [info@benchchem.com](mailto:info@benchchem.com) or [Request Quote Online](#).

## Sources

- [1. researchgate.net \[researchgate.net\]](#)
- [2. mdpi.com \[mdpi.com\]](#)
- [3. Advances in High-Efficiency Blue OLED Materials | Scilit \[scilit.com\]](#)
- [4. researchgate.net \[researchgate.net\]](#)
- [5. Highly Efficient Long-Wavelength Thermally Activated Delayed Fluorescence OLEDs Based on Dicyanopyrazino Phenanthrene Derivatives - PubMed \[pubmed.ncbi.nlm.nih.gov\]](#)
- [6. ossila.com \[ossila.com\]](#)

- [7. researchgate.net \[researchgate.net\]](#)
- [8. Advancing efficiency in deep-blue OLEDs: Exploring a machine learning–driven multiresonance TADF molecular design - PMC \[pmc.ncbi.nlm.nih.gov\]](#)
- [9. Toward highly efficient deep-blue OLEDs: Tailoring the multiresonance-induced TADF molecules for suppressed excimer formation and near-unity horizontal dipole ratio - PMC \[pmc.ncbi.nlm.nih.gov\]](#)
- [10. Highly Efficient Deep-Blue OLEDs using a TADF Emitter with a Narrow Emission Spectrum and High Horizontal Emitting Dipole Ratio - PubMed \[pubmed.ncbi.nlm.nih.gov\]](#)
- [11. mdpi.com \[mdpi.com\]](#)
- [12. researchgate.net \[researchgate.net\]](#)
- [13. researchgate.net \[researchgate.net\]](#)
- [14. tailorpixels.com \[tailorpixels.com\]](#)
- [15. azom.com \[azom.com\]](#)
- [16. Facile synthesis of 2-aza-9,10-diphenylanthracene and the effect of precise nitrogen atom incorporation on OLED emitters performance - PMC \[pmc.ncbi.nlm.nih.gov\]](#)
- [17. researchgate.net \[researchgate.net\]](#)
- [18. Recent advances in highly efficient small-molecule TADF emitters for solution-processed OLEDs - Journal of Materials Chemistry C \(RSC Publishing\) \[pubs.rsc.org\]](#)
- [To cite this document: BenchChem. \[Benchmarking the Efficiency of DPA Derivatives in Deep-Blue OLEDs: A Comparative Guide\]. BenchChem, \[2026\]. \[Online PDF\]. Available at: \[https://www.benchchem.com/product/b1593163/docs#benchmarking-the-efficiency-of-dpa-derivatives-in-deep-blue-oleds-a-comparative-guide\]](#)

---

### Disclaimer & Data Validity:

The information provided in this document is for Research Use Only (RUO) and is strictly not intended for diagnostic or therapeutic procedures. While BenchChem strives to provide accurate protocols, we make no warranties, express or implied, regarding the fitness of this product for every specific experimental setup.

**Technical Support:** The protocols provided are for reference purposes. Unsure if this reagent suits your experiment?

**Need Industrial/Bulk Grade?** [Request Custom Synthesis Quote](#)

# BenchChem

Our mission is to be the trusted global source of essential and advanced chemicals, empowering scientists and researchers to drive progress in science and industry.

## Contact

Address: 3281 E Guasti Rd

Ontario, CA 91761, United States

Phone: (601) 213-4426

Email: [info@benchchem.com](mailto:info@benchchem.com)

[Contact our Ph.D. Support Team for a compatibility check](#)