

Technical Support Center: Temperature Optimization for 4-(2-Methylpropoxy)benzotrile Synthesis

Author: BenchChem Technical Support Team. **Date:** May 2026

Compound of Interest

Compound Name: 4-(2-Methylpropoxy)benzotrile

CAS No.: 5203-15-6

Cat. No.: B1592415

[Get Quote](#)

Department: Chemical Process Optimization & Scale-Up Support Document ID: TSC-2024-FEB-ISO Subject: Thermodynamic and Kinetic Control in the Alkylation of 4-Hydroxybenzotrile Target Molecule: **4-(2-Methylpropoxy)benzotrile** (Key Intermediate for Febuxostat)[1]

Executive Summary & Core Directive

The Challenge: Synthesizing **4-(2-methylpropoxy)benzotrile** requires the alkylation of 4-hydroxybenzotrile with isobutyl bromide (or iodide).[1] While this is a standard Williamson Ether Synthesis, the isobutyl group presents a specific kinetic barrier due to

-branching.[1]

The Directive: Temperature is your primary control lever.[1]

- Too Low (< 60°C): The reaction stalls due to the steric hindrance of the isobutyl group inhibiting

attack.[1]

- Too High (> 100°C): You trigger

elimination, converting your alkylating agent into isobutylene gas, and risk hydrolysis of the nitrile group.[1]

Optimal Target Window: 80°C ± 5°C in polar aprotic solvents (DMF/NMP).

The Thermodynamic Landscape (Theory)

To troubleshoot effectively, you must understand the "Beta-Branching Penalty." [1]

In a standard

reaction, the nucleophile (phenoxide ion) attacks the backside of the carbon-halide bond.[1]

However, the isobutyl group has a methyl branch on the beta-carbon.[1] This creates significant steric bulk near the reaction center, raising the Activation Energy (

).[1]

- Kinetic Consequence: Reaction rates for isobutyl halides are roughly 30x slower than n-butyl halides at the same temperature.[1]
- Thermal Requirement: You must supply enough thermal energy to overcome this elevated barrier, which renders low-boiling solvents (like Acetone, bp 56°C) ineffective for this specific substrate.[1]

Visualization: Reaction Energy Profile

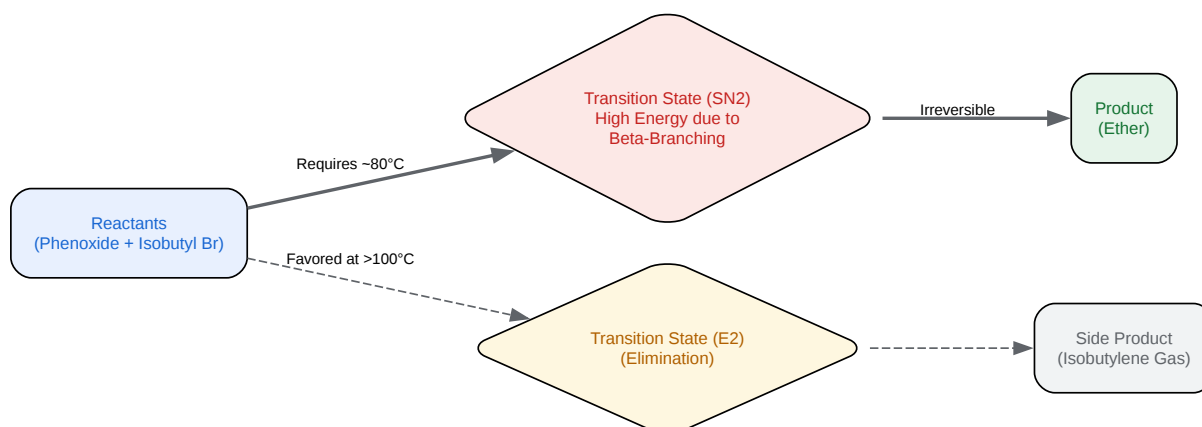

[Click to download full resolution via product page](#)

Figure 1: The kinetic competition between substitution (

) and elimination (

).^[1] Note that excessive heat lowers the selectivity, favoring the entropic release of isobutylene gas.

Standard Operating Protocol (Baseline)

Use this baseline to validate your current setup.^[1] Deviations from these parameters are likely the root cause of your temperature instability.

Parameter	Standard Condition	Rationale
Solvent	DMF (N,N-Dimethylformamide)	High boiling point (153°C) and high dielectric constant dissociate the base/nucleophile ion pair.[1]
Base	(Potassium Carbonate)	Mild enough to prevent rapid nitrile hydrolysis, strong enough to deprotonate the phenol.[1]
Reagent Ratio	1.0 eq Phenol : 1.2 eq Isobutyl Bromide	Excess alkyl halide compensates for loss due to minor elimination side reactions.[1]
Temperature	80°C	The "Sweet Spot" for kinetics vs. impurity profile.[1]
Atmosphere	Nitrogen ()	Prevents oxidation of the phenoxide anion (darkening of reaction).[1]

Troubleshooting Guide

Scenario A: Reaction is stalled (High Starting Material)

Symptom: After 12 hours, HPLC shows >10% 4-hydroxybenzotrile remaining.[1]

- Root Cause 1:Temperature Insufficiency. If running in Acetone (reflux ~56°C) or THF (66°C), the energy is insufficient to overcome the isobutyl steric barrier.[1]
- Root Cause 2:Hydration. Wet solvent creates a solvation shell around the nucleophile (phenoxide), reducing its reactivity.[1]
- Corrective Action:
 - Switch solvent to anhydrous DMF.[1]

- Increase internal temperature to 85-90°C.
- Add catalytic Potassium Iodide (KI, 0.1 eq).[1] This performs an in-situ Finkelstein reaction, converting the unreactive Isobutyl Bromide to the highly reactive Isobutyl Iodide.
[1]

Scenario B: Pressure Buildup & Low Yield

Symptom: Reactor pressure rises; yield is low; smell of olefin.[1]

- Root Cause: Thermal Overshoot (>110°C). You have crossed the threshold where elimination becomes competitive.[1] The base is deprotonating the isobutyl bromide rather than the phenol, generating isobutylene gas.[1]
- Corrective Action:
 - Lower mantle/jacket temperature immediately to 75-80°C.
 - Check agitation rate (poor mixing can cause local hot spots).[1]

Scenario C: Product Darkening / New Impurity at RRT ~0.8

Symptom: Reaction mixture turns dark brown/black; new peak appears.[1]

- Root Cause: Nitrile Hydrolysis or Solvent Decomposition. At high temperatures (>100°C) with carbonate bases, the nitrile group can hydrolyze to the amide.[1] Alternatively, DMF can decompose to dimethylamine, reacting with the starting material.[1]
- Corrective Action:
 - Verify temperature probe calibration.[1]
 - Ensure the system is strictly anhydrous (water promotes hydrolysis).[1]

Visual Troubleshooting Logic

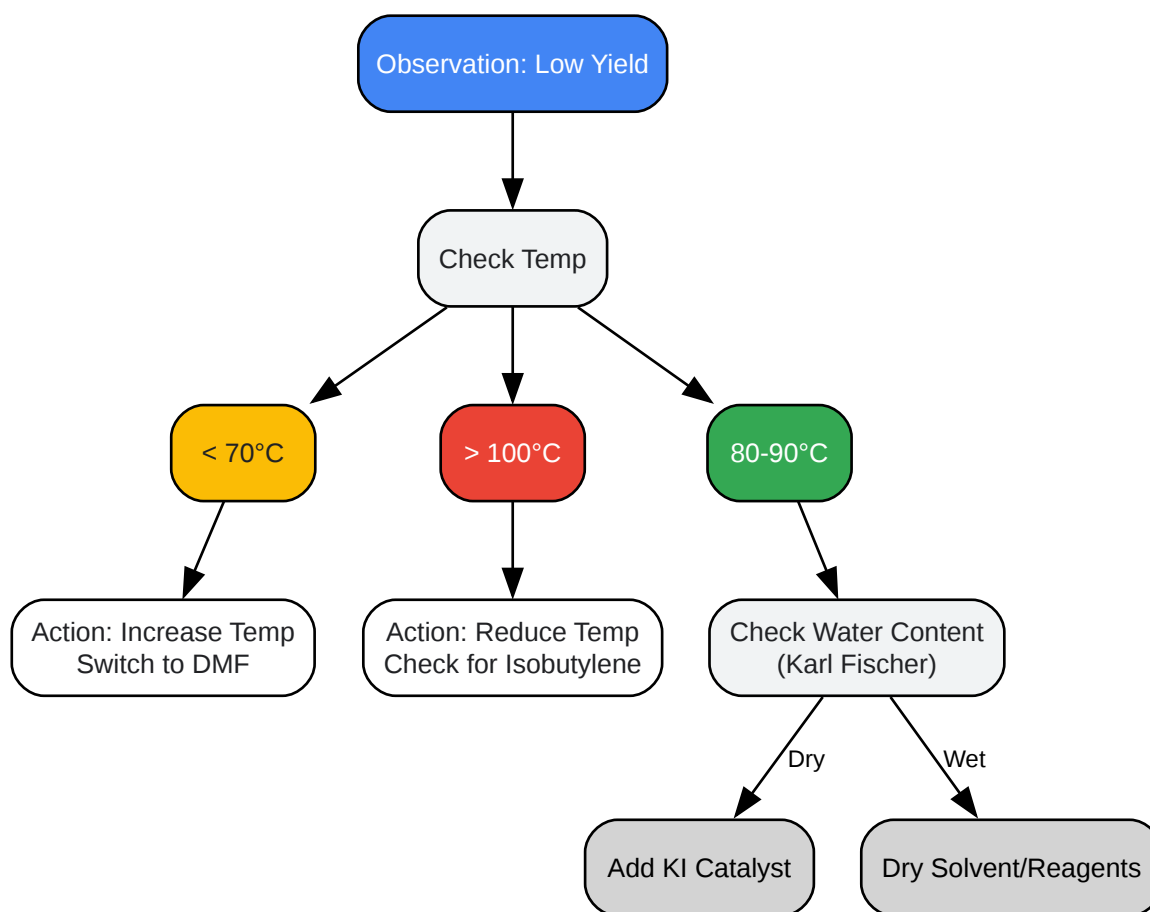

[Click to download full resolution via product page](#)

Figure 2: Decision matrix for thermal optimization.[1]

Frequently Asked Questions (FAQ)

Q1: Can I use Acetone as a solvent to simplify workup? A: Not recommended. Acetone boils at 56°C. Due to the

-branching of the isobutyl group, the reaction rate at 56°C is glacially slow. You will likely observe incomplete conversion even after 48 hours.[1] If you must use a lower boiling solvent, Acetonitrile (bp 82°C) is a better compromise, though DMF remains superior for kinetics.[1]

Q2: Why does the reaction mixture turn solid/slurry during the reaction? A: This is normal. As the reaction proceeds, Potassium Bromide (KBr) precipitates out of the DMF solution because it is less soluble than the starting reactants.[1] Ensure your agitation is powerful enough to keep these solids suspended to prevent "hot spots" on the reactor wall.[1]

Q3: Can I use Sodium Hydride (NaH) to lower the reaction temperature? A: Proceed with extreme caution. While NaH is a stronger base and can drive the reaction at lower temperatures (e.g., 0-25°C), it presents significant safety risks with DMF (potential for runaway exotherms).[1] Furthermore, the "hard" nature of the hydride anion can increase the rate of elimination (isobutylene formation) if the temperature is not strictly controlled.[1]

is preferred for its "soft" deprotonation and safety profile.[1]

References

- Preparation of Febuxostat Intermediate. Google Patents.[1] Patent CN102924353A.[1] Describes the alkylation of 4-hydroxybenzotrile in DMF/DMSO systems.
- Williamson Ether Synthesis Mechanism. Organic Chemistry Portal.

reactions involving branched substrates.
- Synthesis and Characterization of Process-Related Impurities of Febuxostat. Der Pharma Chemica. Discusses impurity profiles related to thermal degradation during synthesis.
- Febuxostat: Process Chemistry. New Drug Approvals. Overview of industrial routes including the isobutylation step.[1][2][3]

Need Custom Synthesis?

BenchChem offers custom synthesis for rare earth carbides and specific isotopic labeling.

Email: info@benchchem.com or [Request Quote Online](#).

Sources

- [1. researchgate.net](https://www.researchgate.net) [researchgate.net]
- [2. researchgate.net](https://www.researchgate.net) [researchgate.net]
- [3. mdpi.com](https://www.mdpi.com) [mdpi.com]
- To cite this document: BenchChem. [Technical Support Center: Temperature Optimization for 4-(2-Methylpropoxy)benzotrile Synthesis]. BenchChem, [2026]. [Online PDF]. Available at: [\[https://www.benchchem.com/product/b1592415/docs#technical-support-center-temperature-optimization-for-4-2-methylpropoxy-benzotrile-synthesis\]](https://www.benchchem.com/product/b1592415/docs#technical-support-center-temperature-optimization-for-4-2-methylpropoxy-benzotrile-synthesis)

Disclaimer & Data Validity:

The information provided in this document is for Research Use Only (RUO) and is strictly not intended for diagnostic or therapeutic procedures. While BenchChem strives to provide accurate protocols, we make no warranties, express or implied, regarding the fitness of this product for every specific experimental setup.

Technical Support: The protocols provided are for reference purposes. Unsure if this reagent suits your experiment?

Need Industrial/Bulk Grade? [Request Custom Synthesis Quote](#)

BenchChem

Our mission is to be the trusted global source of essential and advanced chemicals, empowering scientists and researchers to drive progress in science and industry.

Contact

Address: 3281 E Guasti Rd
Ontario, CA 91761, United States
Phone: (601) 213-4426
Email: info@benchchem.com

[Contact our Ph.D. Support Team for a compatibility check](#)