

Technical Guide: ^1H NMR Characterization of 5-Chloro-2-hydroxyphenylboronic Acid

Author: BenchChem Technical Support Team. **Date:** May 2026

Compound of Interest

Compound Name:	5-Chloro-2-hydroxyphenylboronic acid
CAS No.:	89488-25-5
Cat. No.:	B1592813

[Get Quote](#)

CAS: 89488-25-5 | Formula: $\text{C}_6\text{H}_6\text{BClO}_3$ | MW: 172.37 g/mol

Executive Summary

5-Chloro-2-hydroxyphenylboronic acid is a functionalized arylboronic acid frequently employed as a building block in Suzuki-Miyaura cross-coupling reactions and as a pharmacophore in benzoxaborole antifungal development.

Obtaining a clean ^1H NMR spectrum for this compound is chemically non-trivial due to two competing equilibria:

- **Boroxine Formation:** The reversible dehydration of the boronic acid moiety into a cyclic trimeric anhydride (boroxine).
- **Proton Exchange:** The lability of the phenolic ($-\text{OH}$) and boronic [$-\text{B}(\text{OH})_2$] protons, which complicates integration and peak shape.

This guide provides the characteristic spectral data in DMSO-d₆ (the standard solvent for suppressing exchange) and a self-validating protocol to ensure sample integrity.

Structural Analysis & Proton Assignment

The molecule consists of a trisubstituted benzene ring. The chemical shifts are governed by the strong electron-donating effect of the phenolic hydroxyl group (C-2) and the inductive withdrawing effects of the chlorine (C-5) and boronic acid (C-1) groups.

Chemical Structure Diagram

The following diagram illustrates the proton numbering scheme used in the spectral data table.

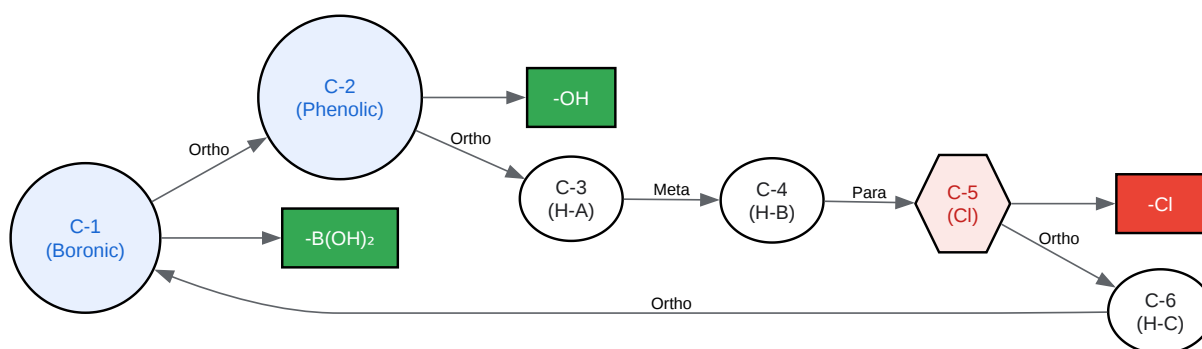

[Click to download full resolution via product page](#)

Figure 1: Connectivity and substitution pattern of **5-Chloro-2-hydroxyphenylboronic acid**. Note the shielding influence of the C-2 OH group on H-A (C-3).

Characteristic ¹H NMR Spectral Data

Solvent: DMSO-d₆ | Frequency: 400 MHz | Reference: TMS (0.00 ppm) or Residual DMSO (2.50 ppm)

Assignment	Shift (δ , ppm)	Multiplicity	Integration	Coupling Constant (, Hz)	Structural Justification
Phenolic -OH	9.80 – 10.50	Singlet (br)	1H	—	Highly deshielded due to H-bonding; often broad.
Boronic - B(OH) ₂	8.00 – 8.80	Singlet (br)	2H	—	Exchangeable protons; chemical shift is concentration-dependent.
H-C (C-6)	7.55 – 7.65	Doublet (d)	1H		Ortho to Boron (deshielding); Meta to Cl.
H-B (C-4)	7.25 – 7.35	dd	1H	,	Meta to OH; Ortho to Cl. Shows coupling to H-3 and H-6.
H-A (C-3)	6.80 – 6.90	Doublet (d)	1H		Ortho to OH (strong shielding); Meta to Cl.

Detailed Interpretation Logic

- The Aromatic Region (6.8 – 7.7 ppm):
 - H-3 (H-A): This proton appears furthest upfield (~6.85 ppm). It is located ortho to the strong electron-donating hydroxyl group, which increases electron density at this position

via resonance, resulting in significant shielding.

- H-6 (H-C): This proton appears furthest downfield (~7.60 ppm). It is ortho to the boronic acid group.^[1] Although boron is electropositive, the empty p-orbital can participate in resonance, and the lack of ortho-shielding (compared to H-3) leaves it relatively deshielded.
- H-4 (H-B): The signal at ~7.30 ppm is a doublet of doublets (dd). It couples strongly with its ortho neighbor H-3 (Hz) and weakly with its meta neighbor H-6 (Hz).
- The Exchangeable Region (8.0 – 10.5 ppm):
 - In "wet" DMSO or at low concentrations, the phenolic and boronic protons may coalesce into a single broad hump or disappear entirely due to rapid exchange with water.
 - In dry DMSO-d₆, the phenolic proton is typically distinct and sharpest, while the boronic protons appear as a broad singlet integrating to 2 protons.

Experimental Protocol: Sample Preparation

To ensure reproducibility and prevent the formation of boroxine anhydrides, follow this strict protocol.

Reagents Required^{[2][3][4][5][6][7][8]}

- Solvent: DMSO-d₆ (99.9 atom % D) + 0.03% v/v TMS.
 - Critical: Use a fresh ampoule or solvent stored over 4Å molecular sieves. Water content >0.1% will collapse the -OH signals.
- Tube: 5mm Precision NMR tube (e.g., Wilmad 507-PP or equivalent).

Step-by-Step Methodology

- Weighing: Weigh 10–15 mg of **5-Chloro-2-hydroxyphenylboronic acid** into a clean vial.

- Note: Do not exceed 20 mg/0.6 mL. High concentrations favor boroxine trimerization.
- Dissolution: Add 0.6 mL of DMSO- d_6 . Vortex until fully dissolved.
 - Observation: The solution should be clear and colorless to pale yellow.
- Dehydration Check (Optional but Recommended): If the solid has been stored for long periods, it may contain partial anhydrides.
 - Action: Add 1 drop of D_2O only if you intend to collapse all exchangeable protons to simplify the aromatic region. For full characterization including OH groups, strictly avoid D_2O .
- Acquisition: Run the 1H NMR experiment with a sufficient relaxation delay (d1 2 seconds) to allow full relaxation of the quaternary carbons if running ^{13}C , or to ensure accurate integration of the aromatic protons.

Troubleshooting & Quality Control

Boronic acids are dynamic molecules. Use the following decision tree to diagnose spectral anomalies.

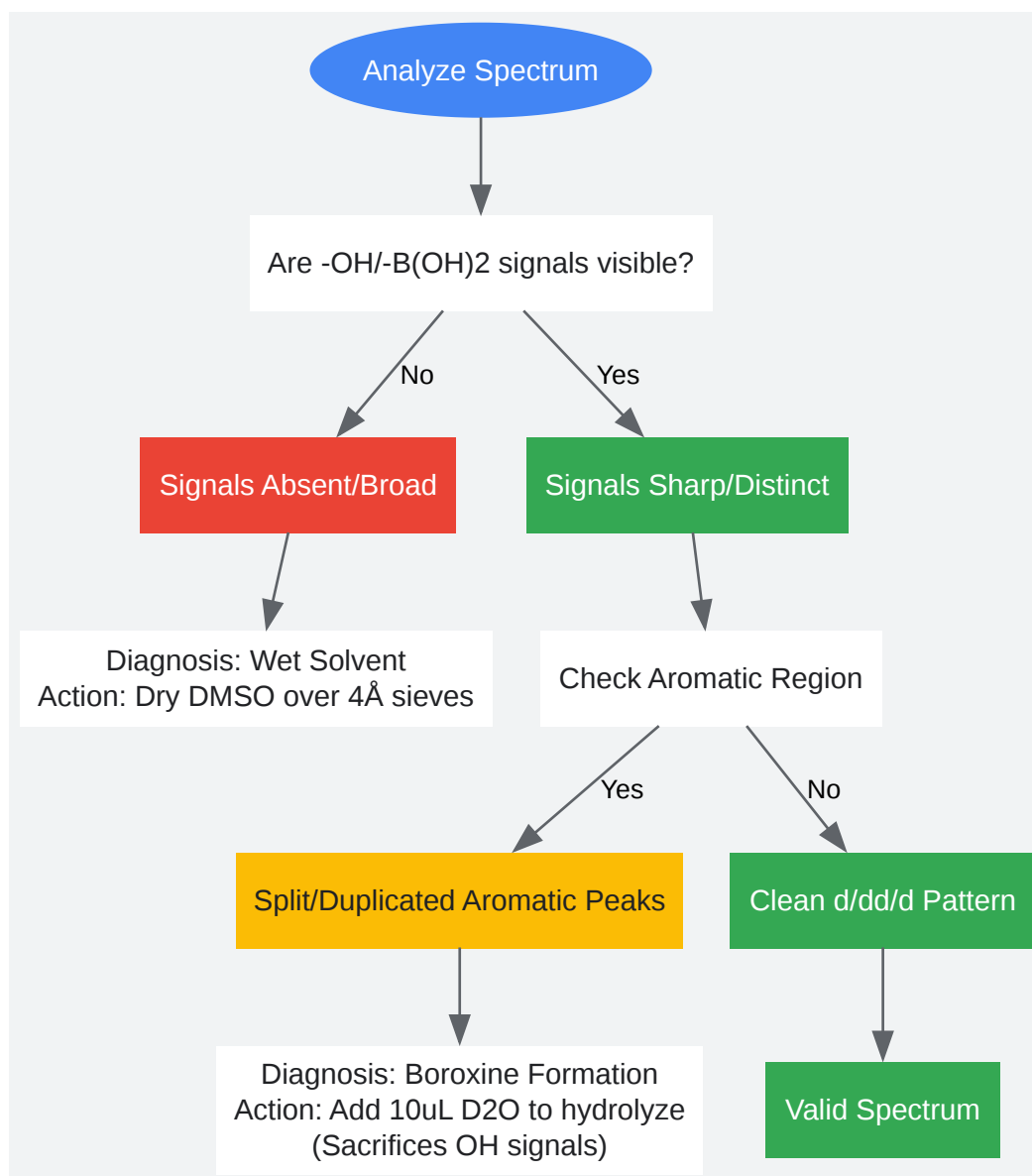

[Click to download full resolution via product page](#)

Figure 2: Diagnostic workflow for evaluating spectral quality of arylboronic acids.

Common Pitfalls

- **Boroxine Contamination:** If you see a second set of aromatic peaks (usually slightly downfield), your sample contains the cyclic anhydride (boroxine). This is common in older samples. Adding a small amount of water (or D₂O) shifts the equilibrium back to the free acid monomer.

- Temperature Effects: The rotation of the B-C bond can be restricted. If peaks are unusually broad, running the experiment at 300K or 310K can sharpen the signals.

Applications & Context

Understanding the NMR of this compound is critical for:

- Suzuki-Miyaura Coupling: Verifying the purity of the starting material directly correlates to catalyst turnover numbers (TON). Impurities like the de-boronated phenol (3-chlorophenol) will poison Pd catalysts.
- Benzoxaborole Synthesis: This compound is a precursor to cyclic boron-oxygen heterocycles, a class of compounds gaining traction as anti-inflammatory and antifungal agents (e.g., Tavaborole).

References

- Synthesis & Properties
 - Torssell, K. (1963). "Arylboronic acids.[1][2][3] I. Synthesis and physicochemical properties." [4] Tetrahedron, 19(1), 821-826.
- General NMR Data for Boronic Acids
 - Hall, D. G. (Ed.). [5] (2011). [6] Boronic Acids: Preparation and Applications in Organic Synthesis, Medicine and Materials. Wiley-VCH.
- Solvent Effects & Sample Prep
 - Babij, N. R., et al. (2016). "NMR Chemical Shifts of Trace Impurities: Industrially Preferred Solvents Used in Process and Green Chemistry." Organic Process Research & Development, 20(3), 661-667. [7]
- Boroxine/Boronic Acid Equilibrium
 - IUPAC. (2014). "Nomenclature of Organic Chemistry: IUPAC Recommendations and Preferred Names 2013." (Blue Book).

Need Custom Synthesis?

BenchChem offers custom synthesis for rare earth carbides and specific isotopic labeling.

Email: info@benchchem.com or [Request Quote Online](#).

Sources

- [1. researchgate.net \[researchgate.net\]](#)
- [2. researchgate.net \[researchgate.net\]](#)
- [3. Organic Chemistry \[3asenrise.com\]](#)
- [4. chemrevlett.com \[chemrevlett.com\]](#)
- [5. How to make an NMR sample \[chem.ch.huji.ac.il\]](#)
- [6. scs.illinois.edu \[scs.illinois.edu\]](#)
- [7. 3-METHYL-2,5-DIHYDROTHIOPHENE-1,1-DIOXIDE\(1193-10-8\) 1H NMR \[m.chemicalbook.com\]](#)
- To cite this document: BenchChem. [Technical Guide: 1H NMR Characterization of 5-Chloro-2-hydroxyphenylboronic Acid]. BenchChem, [2026]. [Online PDF]. Available at: [\[https://www.benchchem.com/product/b1592813/docs#technical-guide-1h-nmr-characterization-of-5-chloro-2-hydroxyphenylboronic-acid\]](https://www.benchchem.com/product/b1592813/docs#technical-guide-1h-nmr-characterization-of-5-chloro-2-hydroxyphenylboronic-acid)

Disclaimer & Data Validity:

The information provided in this document is for Research Use Only (RUO) and is strictly not intended for diagnostic or therapeutic procedures. While BenchChem strives to provide accurate protocols, we make no warranties, express or implied, regarding the fitness of this product for every specific experimental setup.

Technical Support: The protocols provided are for reference purposes. Unsure if this reagent suits your experiment?

Need Industrial/Bulk Grade? [Request Custom Synthesis Quote](#)

BenchChem

Our mission is to be the trusted global source of essential and advanced chemicals, empowering scientists and researchers to drive progress in science and industry.

Contact

Address: 3281 E Guasti Rd

Ontario, CA 91761, United States

Phone: (601) 213-4426

Email: info@benchchem.com

[Contact our Ph.D. Support Team for a compatibility check](#)