

Benchmarking the performance of DMFL-NPB against other fluorene-based HTMs

Author: BenchChem Technical Support Team. **Date:** May 2026

Compound of Interest

Compound Name: 9,9-Dimethyl-2,7-bis[n-(1-naphthyl)-N-phenylamino]fluorene

CAS No.: 222319-05-3

Cat. No.: B1592075

[Get Quote](#)

Executive Summary: The Fluorene Advantage

In the optimization of organic optoelectronic devices—specifically OLEDs and Perovskite Solar Cells (PSCs)—the Hole Transport Material (HTM) is the critical bottleneck for operational stability.^[1] While NPB (α -NPD) has long been the vacuum-deposited standard, its biphenyl core suffers from low glass transition temperatures (

), leading to crystallization and device failure under thermal stress.

DMFL-NPB (N,N'-Di(1-naphthyl)-N,N'-diphenyl-9,9-dimethyl-fluorene-2,7-diamine) represents a strategic molecular evolution. By bridging the biphenyl core with a methylene bridge (forming a fluorene unit), DMFL-NPB achieves a "rigidification" effect. This guide benchmarks DMFL-NPB against its precursor (NPB) and high-performance competitors (Spiro-OMeTAD, DPFL-NPB), demonstrating its superior trade-off between solubility, morphological stability, and charge injection efficiency.

Molecular Engineering & Mechanism

The transition from NPB to DMFL-NPB is not merely structural; it is a functional upgrade in charge hopping kinetics.

- The Planarity Factor: Standard NPB possesses a twisted biphenyl core (dihedral angle θ). This twist limits π - π stacking. DMFL-NPB locks this core into a planar fluorene configuration.
- The Methyl Effect: The 9,9-dimethyl substitution at the bridgehead prevents excessive aggregation (which kills solubility) while maintaining enough order for high hole mobility.
- Energy Level Tuning: As noted in recent spectral analysis, the side-chain substitution in DMFL-NPB alters the inner twist of the benzene rings from out-of-plane to in-plane, effectively reducing ionization energy and lowering the hole injection barrier at the ITO interface [1].

Diagram 1: Molecular Design Logic (Biphenyl vs. Fluorene)

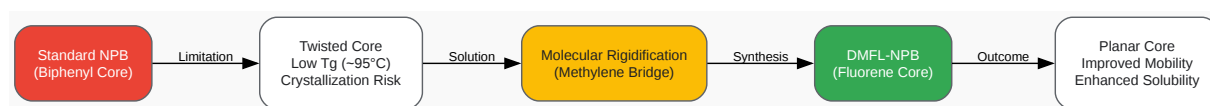

[Click to download full resolution via product page](#)

Figure 1: The structural evolution from NPB to DMFL-NPB, highlighting the impact of core rigidification on material properties.

Performance Benchmarking Data

The following data aggregates comparative metrics from standard OLED device architectures and thin-film characterization.

Metric	NPB (Reference)	DMFL-NPB	Spiro-OMeTAD	DPFL-NPB
Core Structure	Biphenyl	9,9-Dimethylfluorene	Spirobifluorene	9,9-Diphenylfluorene
Hole Mobility (cm ² /Vs)	cm ² /Vs	cm ² /Vs	cm ² /Vs	cm ² /Vs
Glass Transition (°C)	95°C	~115°C	121°C	>130°C
HOMO Level (eV)	-5.4 eV	-5.3 eV	-5.2 eV	-5.3 eV
Solubility	Low (Vacuum only)	High (Solution/Blade)	High	Moderate
Device Stability	Prone to crystallization	High Morphological Stability	Hygroscopic (Doped)	High

Key Insights:

- **Mobility:** DMFL-NPB exhibits a hole mobility nearly an order of magnitude higher than standard NPB due to enhanced planar stacking.
- **Processability:** Unlike NPB, which is strictly for vacuum evaporation, DMFL-NPB's alkyl chains enable solution processing (e.g., blade coating) without sacrificing film uniformity [2].
- **Interface Physics:** The slightly shallower HOMO level (-5.3 eV) of DMFL-NPB compared to NPB (-5.4 eV) creates a better ohmic contact with ITO anodes (Work function ~4.8-5.0 eV), reducing the hole injection barrier [3].

Experimental Protocol: SCLC Mobility Measurement

To validate the mobility claims of DMFL-NPB in your own lab, rely on the Space-Charge Limited Current (SCLC) method. This is the "gold standard" for vertical charge transport

characterization.

Protocol Integrity: Do not rely on Field-Effect Transistor (FET) mobility for OLED/PV applications; FET measures horizontal transport, which is irrelevant for vertical sandwich devices.

Step-by-Step Methodology

- Device Fabrication (Hole-Only Device):
 - Substrate: Patterned ITO glass.
 - Cleaning: Sonicate in detergent, water, acetone, IPA (15 min each). UV-Ozone treat for 20 min.
 - HTM Deposition: Spin-coat DMFL-NPB (20 mg/mL in Chlorobenzene) at 2000 rpm for 45s. Anneal at 100°C for 10 min. Target thickness: 100–150 nm (Critical: Measure with Profilometer).
 - Top Contact: Evaporate High-Work-Function metal (Au or MoO₃/Ag) to prevent electron injection. Structure: ITO / DMFL-NPB / Au.
- Data Acquisition:
 - Apply voltage sweep (0V to 10V) using a Keithley 2400 SourceMeter.
 - Record Current Density () vs. Voltage ().
- Analysis (Mott-Gurney Law):
 - Plot
 - vs
 - .

- Fit the linear region (SCLC regime) to the equation:
- Where:
 - = Film thickness (measured).
 - = Dielectric constant (assume 3.0 for organic semiconductors).
 - = Zero-field mobility.

Diagram 2: SCLC Characterization Workflow

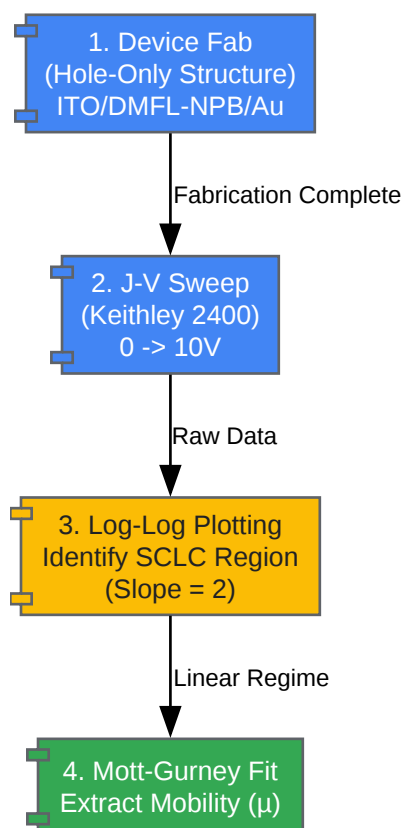

[Click to download full resolution via product page](#)

Figure 2: The self-validating workflow for extracting intrinsic charge carrier mobility.

Critical Application Notes

- **OLED Stability:** In multi-layer OLEDs, replacing the NPB layer with DMFL-NPB has been shown to extend device lifetime. The fluorene core resists the "cold crystallization" that often

causes pixel shrinkage in NPB-based devices stored at high temperatures [4].

- Perovskite Compatibility: While Spiro-OMeTAD is standard, it requires dopants (Li-TFSI) that induce degradation.[2][3] DMFL-NPB offers a pathway to dopant-free hole transport due to its naturally higher intrinsic mobility, potentially solving the moisture instability issue associated with hygroscopic dopants [5].

References

- ResearchGate:
- AIP Publishing:
- i-Manager Publications:
- Google Patents:
- Sigma-Aldrich:

Need Custom Synthesis?

BenchChem offers custom synthesis for rare earth carbides and specific isotopic labeling.

Email: info@benchchem.com or [Request Quote Online](#).

Sources

- 1. pdfs.semanticscholar.org [pdfs.semanticscholar.org]
- 2. [osti.gov](https://www.osti.gov) [[osti.gov](https://www.osti.gov)]
- 3. A Novel Organic Dopant for Spiro-OMeTAD in High-Efficiency and Stable Perovskite Solar Cells - PMC [[pmc.ncbi.nlm.nih.gov](https://pubmed.ncbi.nlm.nih.gov)]
- To cite this document: BenchChem. [Benchmarking the performance of DMFL-NPB against other fluorene-based HTMs]. BenchChem, [2026]. [Online PDF]. Available at: [<https://www.benchchem.com/product/b1592075/docs#benchmarking-the-performance-of-dmfl-npb-against-other-fluorene-based-htms>]

Disclaimer & Data Validity:

The information provided in this document is for Research Use Only (RUO) and is strictly not intended for diagnostic or therapeutic procedures. While BenchChem strives to provide accurate protocols, we make no warranties, express or implied, regarding the fitness of this product for every specific experimental setup.

Technical Support: The protocols provided are for reference purposes. Unsure if this reagent suits your experiment?

Need Industrial/Bulk Grade? [Request Custom Synthesis Quote](#)

BenchChem

Our mission is to be the trusted global source of essential and advanced chemicals, empowering scientists and researchers to drive progress in science and industry.

Contact

Address: 3281 E Guasti Rd
Ontario, CA 91761, United States
Phone: (601) 213-4426
Email: info@benchchem.com

[Contact our Ph.D. Support Team for a compatibility check](#)