

Technical Support Center: Optimizing PI-103 Concentration for Maximum Inhibition

Author: BenchChem Technical Support Team. **Date:** April 2026

Compound of Interest

Compound Name: PI-103 Hydrochloride

CAS No.: 371935-79-4

Cat. No.: B1591684

[Get Quote](#)

This technical support center provides troubleshooting guides and frequently asked questions (FAQs) to assist researchers, scientists, and drug development professionals in optimizing the use of PI-103 for maximum inhibition in their experiments.

Frequently Asked Questions (FAQs)

Q1: What is PI-103 and what is its primary mechanism of action?

PI-103 is a potent, cell-permeable, synthetic small molecule that functions as a dual inhibitor of the Phosphoinositide 3-kinase (PI3K) and mammalian Target of Rapamycin (mTOR) signaling pathways.^{[1][2][3]} It acts as an ATP-competitive inhibitor, targeting the kinase domains of both PI3K and mTOR.^[4] This dual inhibition allows for a more complete blockade of the PI3K/Akt/mTOR pathway, which is often dysregulated in cancer and other diseases.^[3]

Q2: What are the specific isoforms of PI3K and mTOR complexes inhibited by PI-103?

PI-103 exhibits broad-spectrum inhibitory activity against Class I PI3K isoforms and both mTOR complexes (mTORC1 and mTORC2).^{[5][6][7][8]} Its high potency against multiple targets within the pathway makes it a valuable tool for research.^[9]

Q3: How should I prepare and store PI-103 stock solutions?

For in vitro experiments, PI-103 is typically dissolved in dimethyl sulfoxide (DMSO).[5] A stock solution of 10 mM in DMSO is commonly used.[4] To prepare, warm the vial to 37°C for 10 minutes and sonicate if necessary to ensure complete dissolution.[10][11] Stock solutions in DMSO can be stored at -20°C for up to two months or at -80°C for up to one year.[4][6] It is recommended to aliquot the stock solution to avoid repeated freeze-thaw cycles.[6] For in vivo studies, specific formulations involving solvents like PEG300 and Tween80 may be required.[5]

Q4: What is a typical starting concentration for PI-103 in cell culture experiments?

The optimal concentration of PI-103 is highly dependent on the cell line and the specific experimental endpoint. However, a common starting range for in vitro studies is between 0.1 μM and 10 μM.[9][12][13] For example, in some glioblastoma cell lines, significant inhibition of PI3K/Akt and mTORC1 phosphorylation was observed at concentrations as low as 30 nM.[3] In contrast, some leukemia cell lines required 1 μM to block proliferation.[3] It is always recommended to perform a dose-response experiment to determine the optimal concentration for your specific cell type.

Troubleshooting Guide

Issue 1: I am not observing the expected inhibition of my target protein (e.g., phosphorylated Akt or S6K).

Possible Cause	Troubleshooting Step
Suboptimal PI-103 Concentration	Perform a dose-response experiment. Test a broad range of PI-103 concentrations (e.g., 10 nM to 20 μ M) to determine the IC ₅₀ for your specific cell line and target.
Incorrect Drug Preparation or Storage	Prepare a fresh stock solution of PI-103 in high-quality, anhydrous DMSO. Ensure proper storage conditions (-20°C or -80°C in aliquots) to prevent degradation.
Cell Line Resistance	Some cell lines may exhibit intrinsic or acquired resistance to PI3K/mTOR inhibitors. Consider using a different inhibitor or combination therapy.
Short Incubation Time	The inhibitory effect of PI-103 can be time-dependent. Perform a time-course experiment (e.g., 1, 6, 24, 48 hours) to determine the optimal incubation period.
Poor Cell Permeability in Your System	Although PI-103 is generally cell-permeable, specific cell types might have different uptake efficiencies. Verify target inhibition via Western blot or other downstream assays.

Issue 2: I am observing significant off-target effects or cellular toxicity.

Possible Cause	Troubleshooting Step
PI-103 Concentration is Too High	Reduce the concentration of PI-103. The goal is to inhibit the target pathway effectively with minimal toxicity. A dose-response curve for both efficacy and toxicity is crucial.
Solvent (DMSO) Toxicity	Ensure the final concentration of DMSO in your cell culture medium is low (typically $\leq 0.1\%$) to avoid solvent-induced toxicity.
PI-103 also inhibits other kinases	PI-103 is known to inhibit other kinases like DNA-PK at nanomolar concentrations. ^{[6][10]} Be aware of this and consider if it could be contributing to the observed phenotype.

Quantitative Data Summary

Table 1: In Vitro Inhibitory Activity of PI-103 (IC50 values)

Target	IC50 (nM)	Reference
p110 α	2 - 8	^{[5][6][10]}
p110 β	3 - 88	^{[5][6][10]}
p110 δ	3 - 48	^{[5][6]}
p110 γ	15 - 150	^{[5][6]}
mTORC1	20 - 30	^{[5][6]}
mTORC2	83	^[6]
DNA-PK	2 - 23	^{[5][6][10]}

Table 2: Exemplary Effective Concentrations of PI-103 in Cell-Based Assays

Cell Line	Assay	Effective Concentration	Reference
U87MG (Glioblastoma)	Inhibition of Akt Phosphorylation	0.5 μ M	[9]
Leukemic Cell Lines	Inhibition of Proliferation	1 μ M	[3]
H460 (NSCLC)	Growth Inhibition (~60%)	0.5 μ M	[10][11]
A549 (NSCLC)	Growth Inhibition (~60%)	2 μ M	[10][11]
Dalton's Lymphoma Ascites	Pre-treatment	10 μ M	[12][13]

Experimental Protocols

Protocol 1: Determination of Optimal PI-103 Concentration using a Dose-Response Curve

- **Cell Seeding:** Seed your cells of interest in a 96-well plate at a density that allows for logarithmic growth during the experiment.
- **PI-103 Dilution Series:** Prepare a serial dilution of PI-103 in your cell culture medium. A typical starting range would be from 10 nM to 20 μ M. Include a vehicle control (DMSO) at the highest concentration used.
- **Treatment:** After allowing the cells to adhere overnight, replace the medium with the medium containing the different concentrations of PI-103.
- **Incubation:** Incubate the cells for a predetermined time (e.g., 24, 48, or 72 hours), depending on the cell doubling time and the nature of the assay.
- **Cell Viability/Proliferation Assay:** Assess cell viability or proliferation using a suitable method, such as MTT, WST-1, or CellTiter-Glo assay.

- Data Analysis: Plot the cell viability/proliferation against the log of the PI-103 concentration. Use a non-linear regression model to calculate the IC50 value, which represents the concentration of PI-103 that causes 50% inhibition.

Visualizations

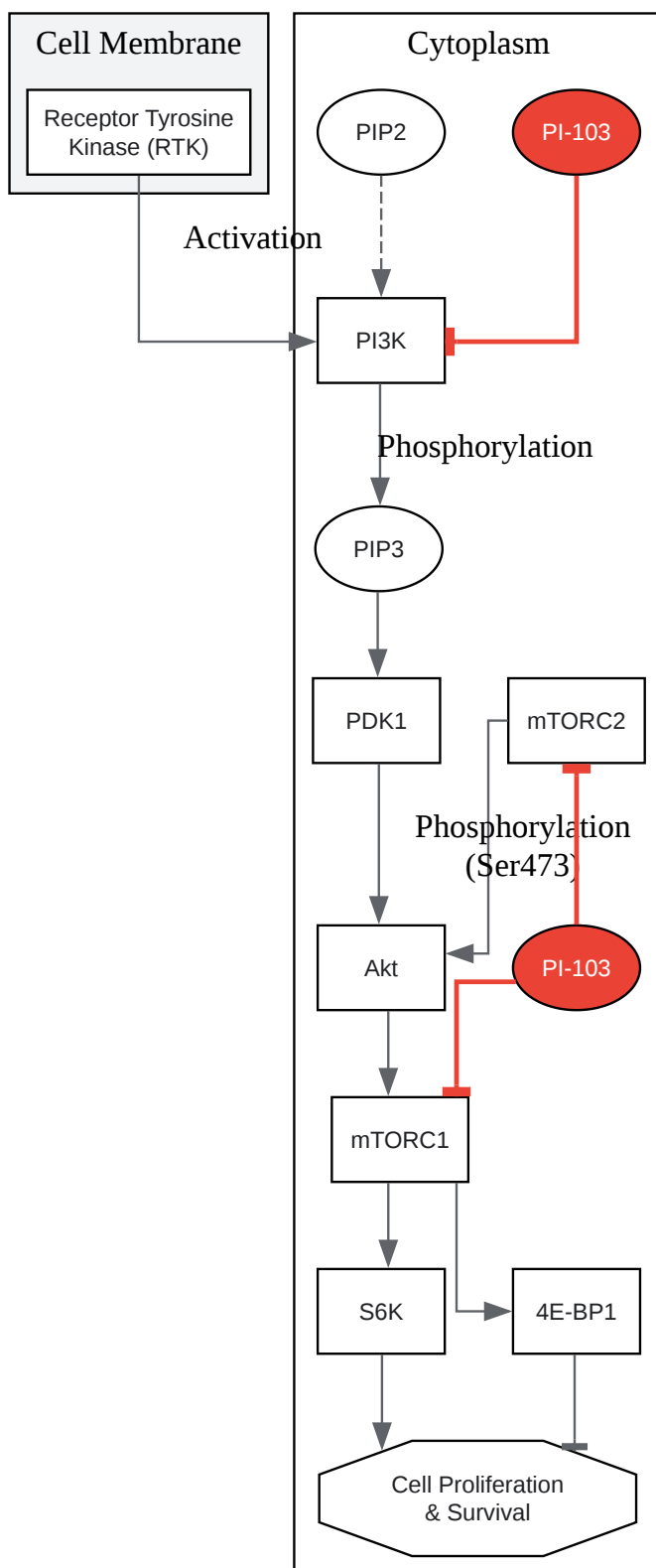

[Click to download full resolution via product page](#)

Caption: PI-103 inhibits the PI3K/Akt/mTOR signaling pathway.

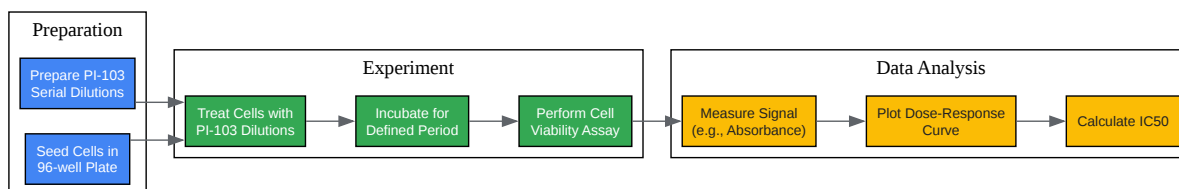

[Click to download full resolution via product page](#)

Caption: Workflow for determining the optimal PI-103 concentration.

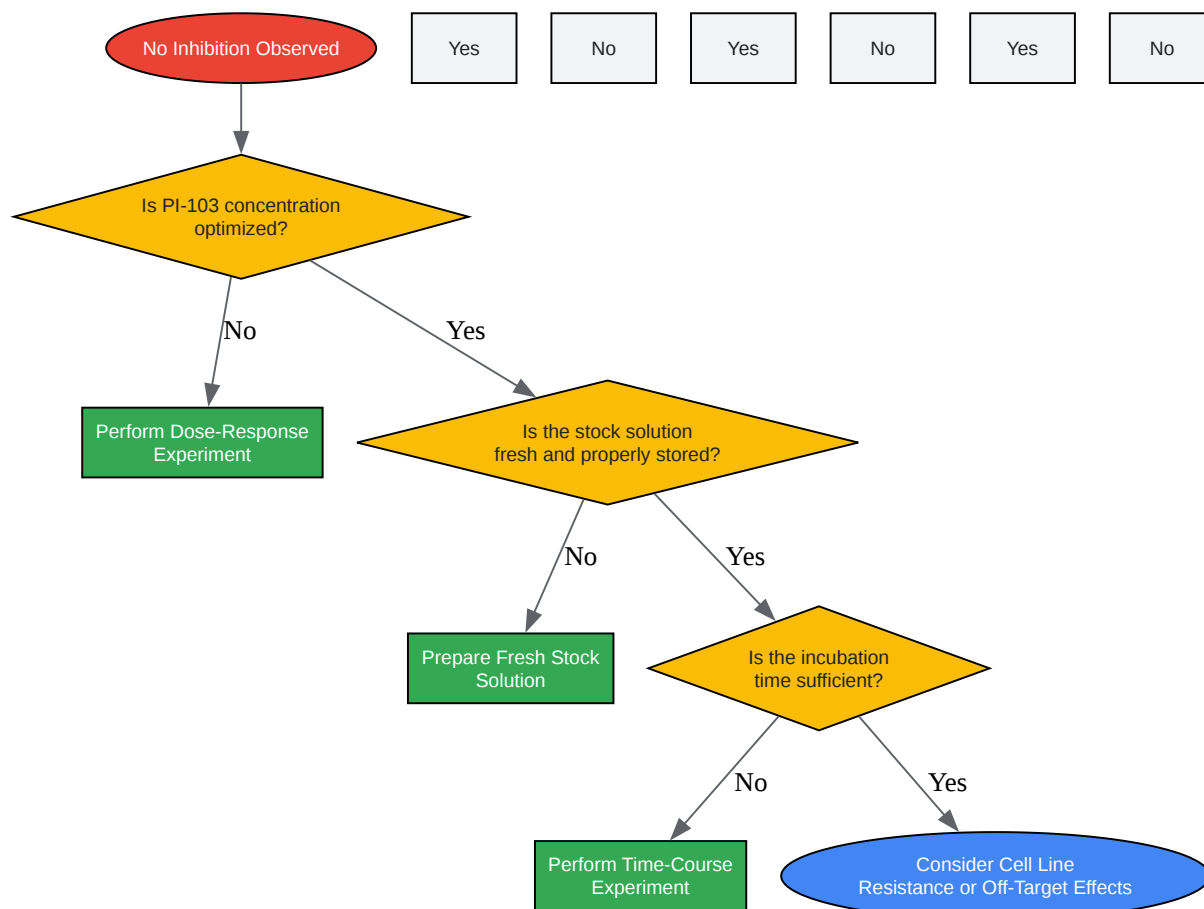

[Click to download full resolution via product page](#)

Caption: Troubleshooting logic for lack of PI-103-induced inhibition.

Need Custom Synthesis?

BenchChem offers custom synthesis for rare earth carbides and specific isotopic labeling.

Email: info@benchchem.com or [Request Quote Online](#).

References

- 1. [Frontiers | Recent Advances in Dual PI3K/mTOR Inhibitors for Tumour Treatment \[frontiersin.org\]](#)
- 2. [Advances in mTOR Inhibitors \[bocsci.com\]](#)
- 3. [apexbt.com \[apexbt.com\]](#)
- 4. [PI-103 | 371935-74-9 \[amp.chemicalbook.com\]](#)
- 5. [selleckchem.com \[selleckchem.com\]](#)
- 6. [medchemexpress.com \[medchemexpress.com\]](#)
- 7. [selleckchem.com \[selleckchem.com\]](#)
- 8. [medchemexpress.com \[medchemexpress.com\]](#)
- 9. [A dual PI3 kinase/mTOR inhibitor reveals emergent efficacy in glioma - PMC \[pmc.ncbi.nlm.nih.gov\]](#)
- 10. [apexbt.com \[apexbt.com\]](#)
- 11. [PI-103 | CAS:371935-74-9 | Class I PI3K, mTOR and DNA-PK inhibitor | High Purity | Manufacturer BioCrick \[biocrick.com\]](#)
- 12. [PI-103 and Quercetin Attenuate PI3K-AKT Signaling Pathway in T- Cell Lymphoma Exposed to Hydrogen Peroxide - PMC \[pmc.ncbi.nlm.nih.gov\]](#)
- 13. [PI-103 and Quercetin Attenuate PI3K-AKT Signaling Pathway in T- Cell Lymphoma Exposed to Hydrogen Peroxide | PLOS One \[journals.plos.org\]](#)
- To cite this document: BenchChem. [Technical Support Center: Optimizing PI-103 Concentration for Maximum Inhibition]. BenchChem, [2026]. [Online PDF]. Available at: [<https://www.benchchem.com/product/b1591684/docs#technical-support-center-optimizing-pi-103-concentration-for-maximum-inhibition>]

Disclaimer & Data Validity:

The information provided in this document is for Research Use Only (RUO) and is strictly not intended for diagnostic or therapeutic procedures. While BenchChem strives to provide accurate protocols, we make no warranties, express or implied, regarding the fitness of this product for every specific experimental setup.

Technical Support: The protocols provided are for reference purposes. Unsure if this reagent suits your experiment?

Need Industrial/Bulk Grade? [Request Custom Synthesis Quote](#)

BenchChem

Our mission is to be the trusted global source of essential and advanced chemicals, empowering scientists and researchers to drive progress in science and industry.

Contact

Address: 3281 E Guasti Rd
Ontario, CA 91761, United States
Phone: (601) 213-4426
Email: info@benchchem.com

[Contact our Ph.D. Support Team for a compatibility check](#)