

# FDN-D-Leu-NH2 molecular weight

**Author:** BenchChem Technical Support Team. **Date:** May 2026

## Compound of Interest

Compound Name:	<i>N</i> alpha-(5-Fluoro-2,4-dinitrophenyl)-D-leucinamide
CAS No.:	178065-30-0
Cat. No.:	B1591017

[Get Quote](#)

An In-depth Technical Guide to the Molecular Weight Determination of Novel Peptides: A Case Study of FDN-D-Leu-NH2

For Researchers, Scientists, and Drug Development Professionals

## Abstract

The determination of the molecular weight of a novel peptide is a foundational step in its characterization, essential for confirming its identity, assessing its purity, and proceeding with further biological and pharmacological studies. This guide provides a comprehensive, in-depth look at the methodologies and analytical strategies required for this critical task, using the example of a hypothetical peptide, FDN-D-Leu-NH2. As "FDN" does not correspond to a standard, readily identifiable chemical moiety, this guide will focus on the investigative workflow a researcher would employ to elucidate the complete structure and, consequently, the precise molecular weight of such a compound. We will delve into the theoretical calculations, the core principles of mass spectrometry, and the experimental protocols necessary for a definitive molecular weight determination.

## Introduction: The Challenge of the Unknown Moiety

In peptide synthesis and drug discovery, researchers often encounter novel molecules where a portion of the structure may not be immediately apparent. The designation "FDN-D-Leu-NH<sub>2</sub>" presents such a scenario. While the C-terminal portion, D-Leucinamide (D-Leu-NH<sub>2</sub>), is a known entity, the N-terminal "FDN" group is ambiguous and does not correspond to a common protecting group or chemical modification in standard peptide nomenclature. This guide will therefore use FDN-D-Leu-NH<sub>2</sub> as a case study to illustrate the process of characterizing a novel peptide with an unknown N-terminal modification.

The core of this process lies in a systematic approach that combines theoretical calculations for the known fragment with advanced analytical techniques, primarily mass spectrometry, to identify the unknown component and confirm the molecular weight of the entire molecule.

## Deconstruction and Theoretical Calculations: The Known Portion

The first step in our analysis is to dissect the known part of the molecule: D-Leucinamide.

### Chemical Structure and Properties of D-Leucinamide

D-Leucinamide is the amide of D-Leucine, an enantiomer of the naturally occurring L-Leucine. Its chemical formula is C<sub>6</sub>H<sub>14</sub>N<sub>2</sub>O<sup>[1]</sup>.

- D-Leucine: An amino acid with the chemical formula C<sub>6</sub>H<sub>13</sub>NO<sub>2</sub> and a molecular weight of approximately 131.17 g/mol <sup>[2]</sup>.
- Amidation: The C-terminal carboxyl group (-COOH) is replaced by an amide group (-CONH<sub>2</sub>).

### Calculating the Monoisotopic and Average Molecular Weight of D-Leucinamide

For high-resolution mass spectrometry, the monoisotopic mass is the more relevant value. It is calculated using the mass of the most abundant isotopes of each element. The average molecular weight is calculated using the natural abundance of all isotopes.

Element	Atomic Symbol	Quantity	Monoisotopic Mass (Da)	Total Monoisotopic Mass (Da)
Carbon	C	6	12.00000	72.00000
Hydrogen	H	14	1.00783	14.10962
Nitrogen	N	2	14.00307	28.00614
Oxygen	O	1	15.99491	15.99491
Total				130.11067

The average molecular weight of D-Leucinamide is approximately 130.19 g/mol [1].

## The Investigative Workflow for Identifying "FDN" and Determining the Total Molecular Weight

The central challenge is to identify the "FDN" moiety. The following experimental workflow is a robust and scientifically sound approach to this problem.

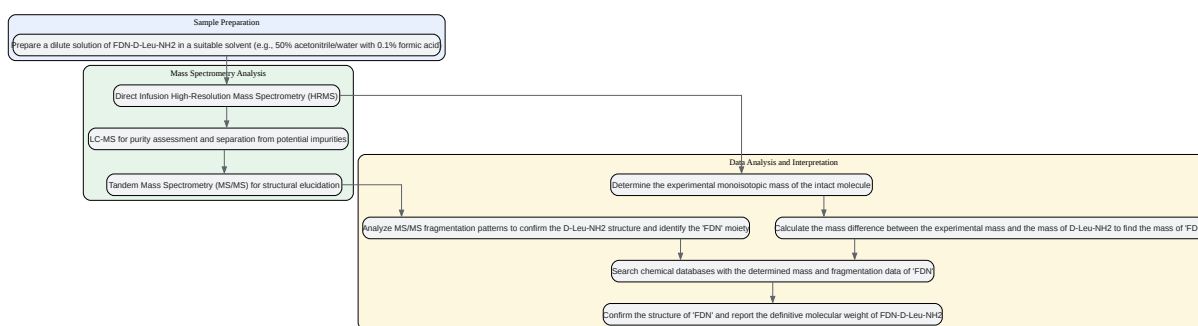

[Click to download full resolution via product page](#)

Caption: Experimental workflow for the determination of the molecular weight and structure of FDN-D-Leu-NH2.

## Step-by-Step Experimental Protocol: High-Resolution Mass Spectrometry

Mass spectrometry is a powerful analytical technique that measures the mass-to-charge ratio ( $m/z$ ) of ionized molecules[3][4]. For peptides, electrospray ionization (ESI) is a commonly used soft ionization technique that preserves the intact molecule.

Protocol for ESI-MS Analysis:

- Sample Preparation:
  - Dissolve a small amount of the FDN-D-Leu-NH<sub>2</sub> sample in a solvent system compatible with ESI-MS, typically a mixture of water and an organic solvent like acetonitrile, with a small amount of acid (e.g., 0.1% formic acid) to promote protonation. A typical starting concentration is 1 µg/mL.
- Instrumentation Setup (example using an Orbitrap mass spectrometer):
  - Ionization Source: Electrospray Ionization (ESI) in positive ion mode.
  - Spray Voltage: 3.5 – 4.5 kV.
  - Capillary Temperature: 275 – 350 °C.
  - Mass Analyzer: Set to perform a full scan (e.g., over a mass range of  $m/z$  100-1000) at high resolution (>60,000).
- Data Acquisition:
  - Infuse the sample directly into the mass spectrometer or inject it via a liquid chromatography (LC) system. LC-MS is preferred as it provides separation from any impurities.
  - Acquire the full scan mass spectrum. The peptide FDN-D-Leu-NH<sub>2</sub> should appear as a protonated molecular ion  $[M+H]^+$ .

## Data Interpretation: From Spectrum to Molecular Weight

The high-resolution mass spectrum will provide the experimental monoisotopic mass of the protonated molecule.

- Experimental Monoisotopic Mass of  $[M+H]^+$  =  $m/z$  value from the mass spectrum.
- Neutral Monoisotopic Mass of FDN-D-Leu-NH<sub>2</sub> (M) = (Experimental Monoisotopic Mass of  $[M+H]^+$ ) - (Monoisotopic Mass of a proton).
  - The monoisotopic mass of a proton is approximately 1.00728 Da.

## Elucidating the "FDN" Moiety: Tandem Mass Spectrometry (MS/MS)

Tandem mass spectrometry (MS/MS) is used to fragment the molecule and gain structural information[5][6].

Protocol for MS/MS Analysis:

- Precursor Ion Selection: In the mass spectrometer, the  $[M+H]^+$  ion of FDN-D-Leu-NH<sub>2</sub> is isolated.
- Fragmentation: The isolated ions are subjected to collision-induced dissociation (CID) or higher-energy collisional dissociation (HCD) to induce fragmentation.
- Fragment Ion Analysis: The resulting fragment ions are mass-analyzed to produce an MS/MS spectrum.

Interpretation of MS/MS Data:

The fragmentation of the peptide bond in D-Leu-NH<sub>2</sub> will produce characteristic b- and y-ions. The presence of these ions will confirm the D-Leucinamide portion of the molecule. The mass difference between the precursor ion and the fragment ions will allow for the determination of the mass of the "FDN" group and potentially reveal its structure through its own fragmentation pattern.

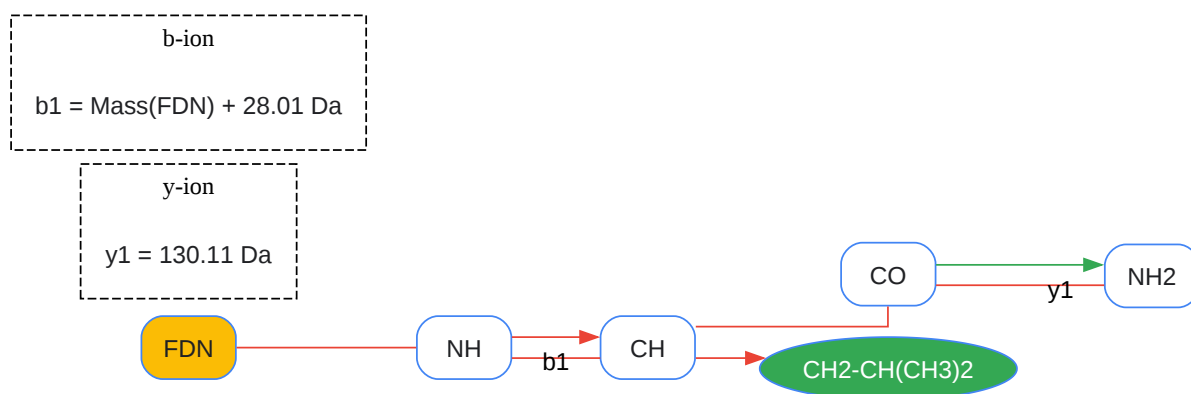

[Click to download full resolution via product page](#)

Caption: Expected fragmentation of FDN-D-Leu-NH<sub>2</sub> showing the formation of b and y ions.

## Hypothetical Scenarios for "FDN"

To illustrate the final step of the analysis, let's consider a few hypothetical identities for "FDN" and their corresponding theoretical molecular weights for FDN-D-Leu-NH<sub>2</sub>.

Hypothetical "FDN" Moiety	Chemical Formula of "FDN"	Monoisotopic Mass of "FDN" (Da)	Total Monoisotopic Mass of FDN-D-Leu-NH <sub>2</sub> (Da)
Formyl	CHO	29.00274	159.11341
Acetyl	C <sub>2</sub> H <sub>3</sub> O	43.01839	173.12906
Dansyl	C <sub>12</sub> H <sub>12</sub> NO <sub>2</sub> S	234.06160	364.17227
Fluorescein isothiocyanate (FITC)	C <sub>21</sub> H <sub>11</sub> NO <sub>5</sub> S	389.04124	519.15191

By comparing the experimentally determined mass of the "FDN" group with the masses of known chemical modifications and searching databases, a confident identification can be

made.

## Conclusion

The determination of the molecular weight of a novel peptide such as FDN-D-Leu-NH<sub>2</sub> is a multi-step, investigative process that is central to chemical and pharmaceutical research. While the ambiguity of the "FDN" moiety initially presents a challenge, a systematic workflow employing high-resolution mass spectrometry and tandem mass spectrometry provides a clear path to its identification and the definitive determination of the total molecular weight. This guide has outlined the theoretical framework, experimental protocols, and data analysis strategies that empower researchers to confidently characterize novel peptides, ensuring the integrity and accuracy of their subsequent scientific endeavors.

## References

- Overview of peptide and protein analysis by mass spectrometry. - PubMed. Available at: [\[Link\]](#)
- Peptide Mass Spectrometry Analysis Principle. - Baitai Paik Biotechnology. Available at: [\[Link\]](#)
- Mass spectrometry of peptides and proteins. - PubMed. Available at: [\[Link\]](#)
- What Is Peptide Mass Spectrometry Identification. - MtoZ Biolabs. Available at: [\[Link\]](#)
- D-Leucine. - PubChem. Available at: [\[Link\]](#)

### *Need Custom Synthesis?*

*BenchChem offers custom synthesis for rare earth carbides and specific isotopic labeling.*

*Email: [info@benchchem.com](mailto:info@benchchem.com) or [Request Quote Online](#).*

## Sources

- 1. CAS 15893-47-7: H-D-LEU-NH<sub>2</sub> | CymitQuimica [[cymitquimica.com](http://cymitquimica.com)]
- 2. D-Leucine | C<sub>6</sub>H<sub>13</sub>NO<sub>2</sub> | CID 439524 - PubChem [[pubchem.ncbi.nlm.nih.gov](http://pubchem.ncbi.nlm.nih.gov)]

- [3. Overview of peptide and protein analysis by mass spectrometry - PubMed \[pubmed.ncbi.nlm.nih.gov\]](#)
- [4. What Is Peptide Mass Spectrometry Identification | MtoZ Biolabs \[mtoz-biolabs.com\]](#)
- [5. Mass spectrometry of peptides and proteins - PubMed \[pubmed.ncbi.nlm.nih.gov\]](#)
- [6. Protein Identification: Peptide Mapping vs. Tandem Mass Spectrometry - Creative Proteomics \[creative-proteomics.com\]](#)
- To cite this document: BenchChem. [FDN-D-Leu-NH2 molecular weight]. BenchChem, [2026]. [Online PDF]. Available at: [\[https://www.benchchem.com/product/b1591017/docs#fdn-d-leu-nh2-molecular-weight\]](https://www.benchchem.com/product/b1591017/docs#fdn-d-leu-nh2-molecular-weight)

---

### Disclaimer & Data Validity:

The information provided in this document is for Research Use Only (RUO) and is strictly not intended for diagnostic or therapeutic procedures. While BenchChem strives to provide accurate protocols, we make no warranties, express or implied, regarding the fitness of this product for every specific experimental setup.

**Technical Support:** The protocols provided are for reference purposes. Unsure if this reagent suits your experiment?

**Need Industrial/Bulk Grade?** [Request Custom Synthesis Quote](#)

## BenchChem

Our mission is to be the trusted global source of essential and advanced chemicals, empowering scientists and researchers to drive progress in science and industry.

### Contact

Address: 3281 E Guasti Rd

Ontario, CA 91761, United States

Phone: (601) 213-4426

Email: [info@benchchem.com](mailto:info@benchchem.com)

Contact our Ph.D. Support Team for a compatibility check