

# Technical Support Center: Pfitzinger Reaction for Quinoline Synthesis

**Author:** BenchChem Technical Support Team. **Date:** May 2026

## Compound of Interest

Compound Name: 2-Chloro-3-hydroxyquinoline-4-carboxylic acid

CAS No.: 847547-91-5

Cat. No.: B1590467

[Get Quote](#)

Welcome to the technical support guide for the Pfitzinger reaction. This resource is designed for researchers, chemists, and drug development professionals engaged in the synthesis of quinoline-4-carboxylic acids. Here, we address common challenges and frequently asked questions in a direct, problem-solving format, grounding our advice in established chemical principles and field-proven experience.

## Part 1: Core Mechanism & Principles FAQ

This section addresses fundamental questions about the Pfitzinger reaction mechanism to provide the causal context for troubleshooting experimental outcomes.

### Q1: What is the fundamental mechanism of the Pfitzinger reaction?

The Pfitzinger reaction is a base-catalyzed condensation between isatin (or a derivative) and a carbonyl compound possessing an  $\alpha$ -methylene group, which ultimately yields a substituted quinoline-4-carboxylic acid.<sup>[1]</sup> The reaction proceeds through several distinct steps:

- Isatin Ring Opening: The reaction begins with the base-catalyzed hydrolysis of the amide bond within the isatin ring, forming a keto-acid intermediate (isatinic acid) in situ.[2]
- Condensation & Imine Formation: The amine of the opened isatin intermediate then condenses with the carbonyl group of the reaction partner (an aldehyde or ketone) to form an imine.[3]
- Tautomerization: The imine rapidly tautomerizes to its more stable enamine form.[1]
- Cyclization & Dehydration: A final intramolecular cyclization (an aldol-type reaction) followed by dehydration yields the aromatic quinoline ring system.[3][4]

Below is a diagram illustrating this mechanistic pathway.

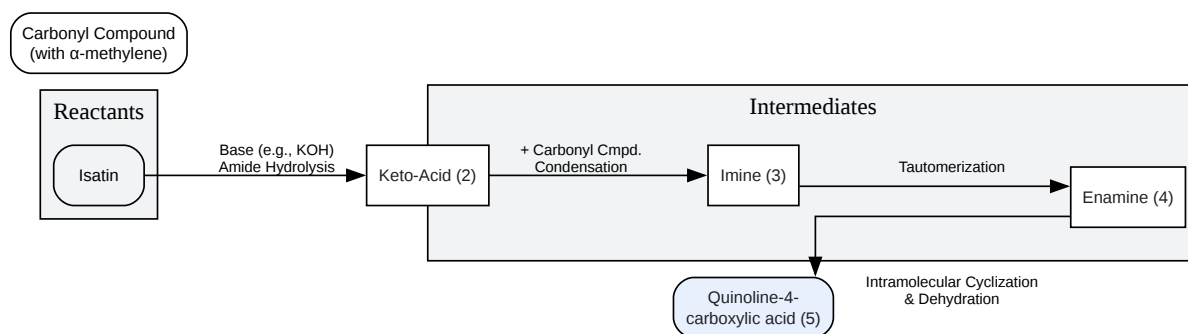

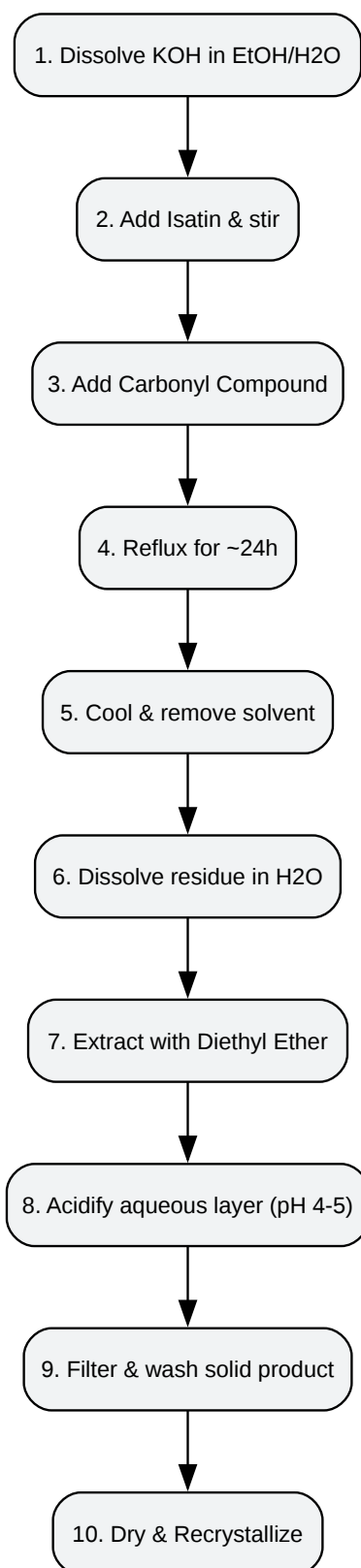

[Click to download full resolution via product page](#)

### Need Custom Synthesis?

BenchChem offers custom synthesis for rare earth carbides and specific isotopic labeling.

Email: [info@benchchem.com](mailto:info@benchchem.com) or [Request Quote Online](#).

## Sources

- [1. benchchem.com \[benchchem.com\]](https://www.benchchem.com)
- [2. Pfitzinger reaction - Wikipedia \[en.wikipedia.org\]](https://en.wikipedia.org)
- [3. youtube.com \[youtube.com\]](https://www.youtube.com)
- [4. researchgate.net \[researchgate.net\]](https://www.researchgate.net)
- To cite this document: BenchChem. [Technical Support Center: Pfitzinger Reaction for Quinoline Synthesis]. BenchChem, [2026]. [Online PDF]. Available at: [\[https://www.benchchem.com/product/b1590467/docs#technical-support-center-pfitzinger-reaction-for-quinoline-synthesis\]](https://www.benchchem.com/product/b1590467/docs#technical-support-center-pfitzinger-reaction-for-quinoline-synthesis)

---

### Disclaimer & Data Validity:

The information provided in this document is for Research Use Only (RUO) and is strictly not intended for diagnostic or therapeutic procedures. While BenchChem strives to provide accurate protocols, we make no warranties, express or implied, regarding the fitness of this product for every specific experimental setup.

**Technical Support:** The protocols provided are for reference purposes. Unsure if this reagent suits your experiment?

**Need Industrial/Bulk Grade?** [Request Custom Synthesis Quote](#)

# BenchChem

Our mission is to be the trusted global source of essential and advanced chemicals, empowering scientists and researchers to drive progress in science and industry.

## Contact

Address: 3281 E Guasti Rd

Ontario, CA 91761, United States

Phone: (601) 213-4426

Email: [info@benchchem.com](mailto:info@benchchem.com)

[Contact our Ph.D. Support Team for a compatibility check](#)