

Technical Support Center: Overcoming Solubility Challenges of Functionalized Carbazoles

Author: BenchChem Technical Support Team. **Date:** May 2026

Compound of Interest

Compound Name: *1,8-Dimethyl-9H-carbazole*

CAS No.: 6558-83-4

Cat. No.: B1590146

[Get Quote](#)

Prepared by the Senior Application Scientist Team

Welcome to the technical support center for researchers, scientists, and drug development professionals working with functionalized carbazoles. The unique electronic and structural properties of carbazole derivatives make them invaluable in pharmaceuticals and material science. However, their characteristically planar and aromatic nature often leads to significant solubility challenges, which can impede experimental progress and drug development.^{[1][2]}

This guide is designed to provide you with practical, in-depth troubleshooting strategies and foundational knowledge to overcome these solubility hurdles. We will move beyond simple protocols to explain the underlying physicochemical principles, empowering you to make informed decisions in your work.

Troubleshooting Guide: A Problem-Oriented Approach

This section addresses specific, common issues encountered during experimentation in a direct question-and-answer format.

Q1: My newly synthesized carbazole derivative is insoluble in everything, including DMSO. Where do I even begin?

A1: Initial Approach: Systematic Solvent Screening and Thermal Assistance.

The insolubility of carbazoles often stems from strong π - π stacking interactions in the crystal lattice, creating a high lattice energy that is difficult for solvents to overcome.[3] Your first step should be a systematic and logical screening of a diverse range of solvents.

Causality: The principle of "like dissolves like" is your starting point. The carbazole core is non-polar, but the functional groups you've added introduce varying degrees of polarity.[4][5] A broad solvent screen is necessary to find the best match for your molecule's specific character.

Experimental Protocol 1: Small-Scale Solvent Screening

- Preparation: Dispense a small, accurately weighed amount (e.g., 1-2 mg) of your carbazole compound into several individual glass vials.
- Solvent Addition: To each vial, add a measured aliquot (e.g., 100 μ L) of a different solvent. Cover a range of polarities as detailed in the table below.
- Initial Observation: Vortex each vial vigorously for 1-2 minutes at room temperature and observe for dissolution.
- Thermal Assistance: If the compound remains insoluble, gently heat the vials (e.g., to 40-50 $^{\circ}$ C) while stirring. Many organic compounds show increased solubility with temperature.[4]
- Incremental Addition: If the compound dissolves, add another aliquot of solvent to determine if it remains in solution at a lower concentration. If it remains insoluble, continue adding solvent in measured aliquots up to a defined volume (e.g., 1 mL) to estimate the solubility limit.
- Documentation: Record your observations meticulously. Note whether dissolution occurred at room temperature, required heating, or if the compound remained insoluble.

Data Presentation: Table of Recommended Solvents for Screening

Solvent	Class	Polarity Index	Rationale for Use
Toluene	Aromatic	2.4	Good for dissolving the non-polar carbazole core.[4]
Dichloromethane (DCM)	Halogenated	3.1	A versatile solvent for many organic compounds.[6]
Tetrahydrofuran (THF)	Ether	4.0	A polar aprotic solvent, good for compounds with some polar functionality.[7]
N,N-Dimethylformamide (DMF)	Amide	6.4	A strong polar aprotic solvent, often effective for stubborn compounds.[6]
Dimethyl Sulfoxide (DMSO)	Sulfoxide	7.2	A highly polar aprotic solvent, one of the most powerful for dissolving diverse structures.[4][8]
Chlorobenzene	Halogenated	-	Specifically noted as an effective solvent for carbazole refining.[9]

Q2: My carbazole compound is for a biological assay and must be dissolved in an aqueous buffer, but it immediately precipitates. What are my options?

A2: Enhancing Aqueous Solubility: A Multi-Strategy Approach.

This is a critical challenge in drug development, as poor aqueous solubility directly impacts bioavailability.[10] Several advanced formulation strategies can be employed, moving from simple adjustments to more complex preparations.

Logical Workflow for Aqueous Solubility Enhancement

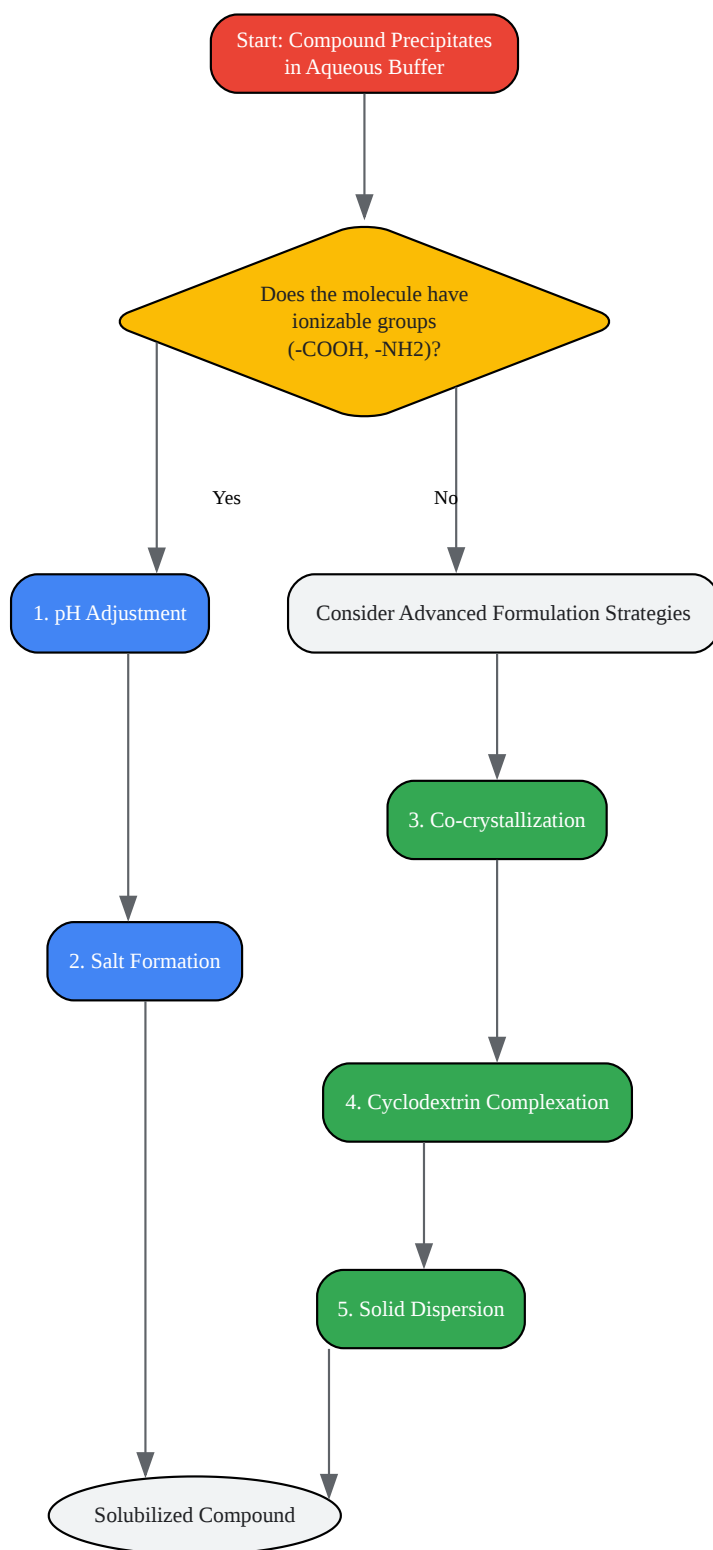

[Click to download full resolution via product page](#)

Caption: Workflow for Aqueous Solubility Troubleshooting.

Strategy 1: pH Adjustment (for ionizable carbazoles)

- Causality: If your carbazole has acidic (e.g., carboxylic acid) or basic (e.g., aliphatic amine) functional groups, its charge state is pH-dependent. By adjusting the pH of the buffer, you can ionize the functional group, making the molecule a salt in situ. This charged species will have vastly improved solubility in polar solvents like water. The carbazole-containing drug Carvedilol, a weak base, exhibits this classic pH-dependent solubility.[\[11\]](#)
- Protocol: See Experimental Protocol 2: pH-Dependent Solubility Profiling.

Strategy 2: Salt Formation

- Causality: For ionizable compounds, forming a stable, solid-state salt is one of the most effective ways to increase solubility and dissolution rates.[\[12\]](#)[\[13\]](#) The ionic interactions of the salt with water are much more favorable than those of the neutral, crystalline parent compound, effectively breaking down the crystal lattice.[\[14\]](#)
- Trustworthiness: A successful salt formation provides a new chemical entity with distinct and measurable physicochemical properties, including a new solubility profile. The key is to select a suitable counter-ion that yields a stable, soluble salt.[\[15\]](#)

Strategy 3: Co-crystallization

- Causality: This technique is ideal for neutral carbazoles or when salt formation fails. A co-crystal is a multi-component crystal where the carbazole and a "coformer" molecule are held together by non-ionic interactions, typically hydrogen bonds.[\[16\]](#)[\[17\]](#) The coformer is a highly water-soluble small molecule (like nicotinamide or an organic acid) that disrupts the carbazole's self-stacking and introduces new, more favorable interactions with water, enhancing solubility.[\[17\]](#)[\[18\]](#)
- Protocol: See Experimental Protocol 3: Trial Cocrystal Screening by Liquid-Assisted Grinding.

Strategy 4: Complexation with Cyclodextrins

- Causality: Cyclodextrins are cone-shaped cyclic oligosaccharides with a hydrophobic interior and a hydrophilic exterior.[19] The non-polar carbazole portion of your molecule can become encapsulated within the hydrophobic cavity, while the water-soluble exterior of the cyclodextrin interacts with the aqueous environment. This forms an "inclusion complex" that effectively shields the hydrophobic drug from the water, dramatically increasing its apparent solubility.[20][21][22]
- Visualization:

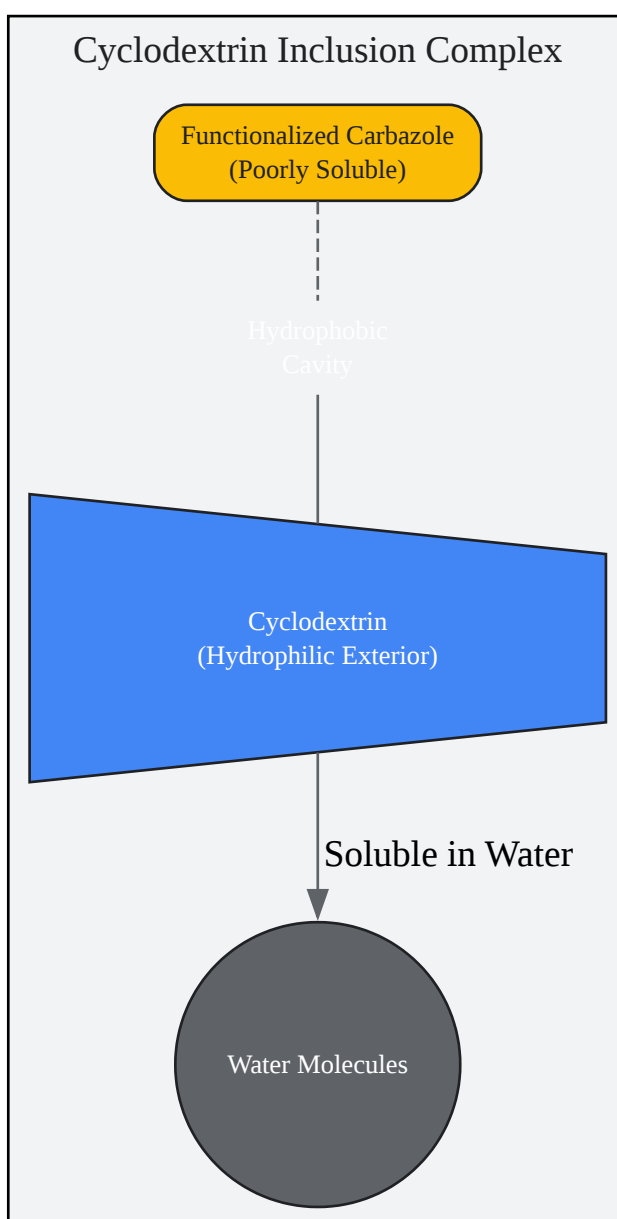

[Click to download full resolution via product page](#)

Caption: Encapsulation of a carbazole within a cyclodextrin.

Strategy 5: Preparation of Solid Dispersions

- **Causality:** A solid dispersion involves dispersing your carbazole compound at the molecular level within a solid, hydrophilic polymer matrix (e.g., PVP, HPMC, or PEGs).[23][24] This process prevents the drug from crystallizing, holding it in a high-energy, amorphous state. [25] The amorphous form lacks the rigid crystal lattice of the crystalline drug, making it much easier to dissolve.[26]
- **Protocol:** See Experimental Protocol 4: Preparation of a Solid Dispersion by Solvent Evaporation.

Frequently Asked Questions (FAQs)

Q1: What is the fundamental reason for the poor solubility of carbazoles?

A1: The core of the issue lies in the molecule's structure. The 9H-carbazole is a large, rigid, and planar aromatic system.[3] This planarity promotes efficient packing in the solid state, leading to strong intermolecular π - π stacking interactions. These forces create a very stable crystal lattice with high energy, which requires a significant amount of energy from a solvent to break apart. While functional groups are added to modulate pharmacological properties, they must also be chosen carefully to disrupt this packing and improve solvation.[3]

Q2: How do different types of functional groups impact solubility?

A2: Functionalization is a double-edged sword. While necessary for biological activity, it can either improve or worsen solubility. Modifying functional groups is a key strategy to improve a drug's absorption and distribution.[5]

Data Presentation: Impact of Functional Groups on Carbazole Solubility

Functional Group Type	Example	General Impact on Aqueous Solubility	Mechanism
Non-polar / Lipophilic	-CH ₃ , -Propyl, -Phenyl	Decreases	Increases the overall hydrophobicity of the molecule, making it less favorable to interact with water. [27]
Polar, Non-ionizable	-OH, -CONH ₂	Can Increase	Introduces hydrogen bonding capability, which can improve interaction with water if it successfully disrupts crystal packing.
Basic (Ionizable)	-NH ₂ , -piperidine	pH-Dependent Increase	Can be protonated at acidic pH to form a highly soluble cationic salt. [11]
Acidic (Ionizable)	-COOH, -SO ₃ H	pH-Dependent Increase	Can be deprotonated at basic pH to form a highly soluble anionic salt. [28]

Q3: What is the practical difference between forming a salt and a cocrystal?

A3: The key difference is proton transfer.

- Salt: A proton is transferred from the acidic species to the basic species, resulting in two ionized molecules held together by a strong ionic bond. This requires a significant difference in pKa between the two components.[\[12\]](#)
- Cocrystal: There is no proton transfer. The carbazole and the cofomer remain neutral and are linked by weaker, non-ionic interactions, such as hydrogen bonds.[\[17\]](#)[\[29\]](#) This makes

cocrystallization a viable strategy for non-ionizable carbazoles.

Visualization: Salt vs. Cocrystal Interaction

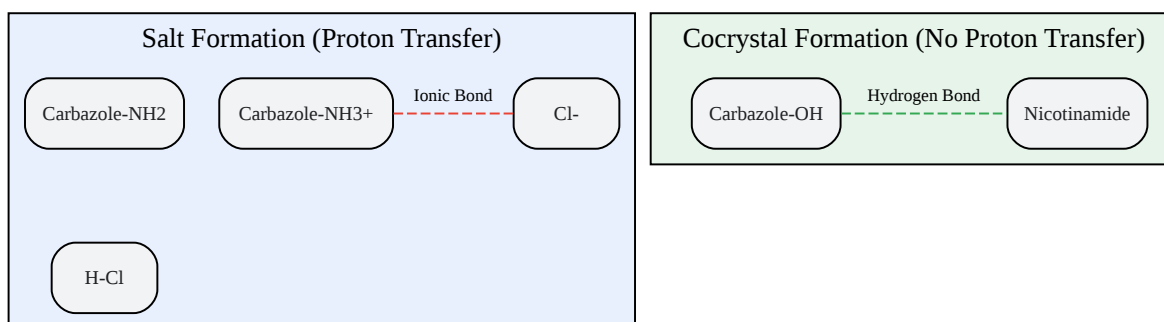

[Click to download full resolution via product page](#)

Caption: Differentiating intermolecular forces in salts and cocrystals.

Experimental Protocols

Protocol 2: pH-Dependent Solubility Profiling

- **Buffer Preparation:** Prepare a series of buffers across a relevant pH range (e.g., pH 2 to pH 10).
- **Sample Preparation:** Add an excess of your carbazole compound to a vial containing a known volume of each buffer. Ensure enough solid is present so that some remains undissolved at equilibrium.
- **Equilibration:** Agitate the vials at a constant temperature (e.g., 25 °C or 37 °C) for a set period (e.g., 24-48 hours) to ensure equilibrium is reached.
- **Phase Separation:** Centrifuge the samples at high speed to pellet the undissolved solid.
- **Quantification:** Carefully remove a known volume of the supernatant, dilute it with a suitable organic solvent, and determine the concentration of the dissolved carbazole using a calibrated analytical method (e.g., HPLC-UV).

- Data Analysis: Plot the measured solubility (e.g., in $\mu\text{g/mL}$) against the pH of the buffer to visualize the pH-solubility profile.

Protocol 3: Trial Cocrystal Screening by Liquid-Assisted Grinding (LAG)

- Component Selection: Choose your carbazole compound and a selection of pharmaceutically acceptable coformers (e.g., nicotinamide, isonicotinamide, benzoic acid).
- Milling: Add the carbazole and a coformer in a defined stoichiometric ratio (e.g., 1:1) to a ball mill jar.
- Liquid Addition: Add a few drops of a solvent (e.g., acetonitrile, ethanol) that both components are sparingly soluble in. The liquid acts as a catalyst for the molecular rearrangement.
- Grinding: Mill the mixture for a set time (e.g., 30-60 minutes).
- Analysis: Analyze the resulting solid powder using techniques like Powder X-ray Diffraction (PXRD) to check for the formation of a new crystalline phase, which would indicate a potential cocrystal.

Protocol 4: Preparation of a Solid Dispersion by Solvent Evaporation

- Dissolution: Dissolve both your carbazole compound and a hydrophilic carrier (e.g., PVP K30) in a common volatile organic solvent (e.g., methanol or a DCM/methanol mixture). A typical drug-to-carrier ratio might be 1:4 by weight.^[26]
- Evaporation: Remove the solvent under vacuum using a rotary evaporator. This should be done relatively quickly to prevent the drug from crystallizing out of the solution as the solvent volume decreases.
- Drying: Further dry the resulting solid film/powder in a vacuum oven overnight to remove any residual solvent.
- Characterization: Scrape the solid dispersion from the flask. Analyze it using PXRD to confirm it is amorphous (i.e., shows a broad halo instead of sharp peaks).

- Solubility Test: Compare the dissolution rate of the solid dispersion in an aqueous buffer against the pure crystalline drug.

References

- Ascendia Pharmaceutical Solutions. (2021, July 26). 5 Novel Techniques for Solubility Enhancement. Retrieved from [\[Link\]](#)
- International Journal of Medical Science and Dental Research. (n.d.). Techniques for Improving Solubility. Retrieved from [\[Link\]](#)
- Ainurofiq, A., Putro, D. S., Ramadhani, D. A., Putra, G. M., & Do Espirito Santo, L. D. C. (2021). A review on solubility enhancement methods for poorly water-soluble drugs. *Journal of Reports in Pharmaceutical Sciences*, 10(2), 137-147. Retrieved from [\[Link\]](#)
- Al-Ghaban, M. A., et al. (2018). pH-Dependent Solubility and Dissolution Behavior of Carvedilol—Case Example of a Weakly Basic BCS Class II Drug. *AAPS PharmSciTech*, 19(6), 2595–2604. Retrieved from [\[Link\]](#)
- Bergström, C. A. S., & Avdeef, A. (2019). Strategies of solubility enhancement and perspectives in solubility measurements of pharmaceutical compounds. *ADMET & DMPK*, 7(3), 159-162. Retrieved from [\[Link\]](#)
- MDPI. (n.d.). Enhancing Febuxostat Solubility Through Cocrystal Formation: Role of Substrate Selection and Amide Cofomers. Retrieved from [\[Link\]](#)
- Solubility of Things. (n.d.). Carbazole. Retrieved from [\[Link\]](#)
- Acme Synthetic Chemicals. (2024, May 6). Impact of Functional Groups in Organic Chemistry on Pharmaceutical Development. Retrieved from [\[Link\]](#)
- MDPI. (2024, July 29). Improving the Solubility, Stability, and Bioavailability of Albendazole through Synthetic Salts. Retrieved from [\[Link\]](#)
- ResearchGate. (2021, October 31). What is the best Strategy for increasing the of solubility for poorly soluble drug (diaryl compounds) in water. Retrieved from [\[Link\]](#)

- Kazi, M., et al. (2021). Bioavailability Enhancement Techniques for Poorly Aqueous Soluble Drugs and Therapeutics. *Pharmaceutics*, 13(5), 735. Retrieved from [\[Link\]](#)
- ResearchGate. (2015, August). Highly Efficient Solvent Screening for Separating Carbazole from Crude Anthracene. Retrieved from [\[Link\]](#)
- Al-Ostath, A., et al. (2023). Design, synthesis, molecular docking and biological evaluation of new carbazole derivatives as anticancer, and antioxidant agents. *PLOS ONE*, 18(6), e0287413. Retrieved from [\[Link\]](#)
- ResearchGate. (2021, July). Carvedilol solubility enhancement by multicomponent crystallization with coformers of benzoic acid, isonicotinamide, and saccharin. Retrieved from [\[Link\]](#)
- ResearchGate. (2022, November 16). Formulation and Evaluation of Solid Dispersion of Poorly Soluble Drugs. Retrieved from [\[Link\]](#)
- Chen, Y., et al. (2017). Novel carbazole sulfonamide derivatives of antitumor agent: Synthesis, antiproliferative activity and aqueous solubility. *Bioorganic & Medicinal Chemistry Letters*, 27(3), 481-486. Retrieved from [\[Link\]](#)
- Popescu, C., et al. (2024). Cyclodextrins: Enhancing Drug Delivery, Solubility and Bioavailability for Modern Therapeutics. *Pharmaceutics*, 17(4), 438. Retrieved from [\[Link\]](#)
- Kumar, A., & Kumar, A. (2021). Recent developments in C–H functionalization of carbazoles. *Tetrahedron*, 94, 132296.
- ResearchGate. (n.d.). Techniques to improve the solubility of poorly soluble drugs. Retrieved from [\[Link\]](#)
- Serajuddin, A. T. M. (2007). Salt formation to improve drug solubility. *Advanced Drug Delivery Reviews*, 59(7), 603-616. Retrieved from [\[Link\]](#)
- Royal Society of Chemistry. (2023, September 29). Synthesis of benzo[a]carbazole derivatives via intramolecular cyclization using Brønsted acidic carbonaceous material as the catalyst. Retrieved from [\[Link\]](#)

- ResearchGate. (2015, November 16). Can I use Cyclodextrin to improve the solubility of a compound?. Retrieved from [\[Link\]](#)
- Tran, P., et al. (2019). Overview of the Manufacturing Methods of Solid Dispersion Technology for Improving the Solubility of Poorly Water-Soluble Drugs and Application to Anticancer Drugs. *Pharmaceutics*, 11(3), 132. Retrieved from [\[Link\]](#)
- Taylor, L. S., & Zhang, G. G. Z. (2016). Cocrystal solubility advantage diagrams as a means to control dissolution, supersaturation and precipitation. *Journal of Pharmaceutical Sciences*, 105(9), 2686-2696. Retrieved from [\[Link\]](#)
- World Pharma Today. (n.d.). Innovative Formulation Strategies for Poorly Soluble Drugs. Retrieved from [\[Link\]](#)
- Deshmukh, A. S., Tiwari, K. J., & Mahajan, V. R. (2017). Solubility Enhancement Techniques for Poorly Water-Soluble Drugs. *International Journal of Pharmaceutical Sciences and Nanotechnology*, 10(2), 3701-3708. Retrieved from [\[Link\]](#)
- Aston University. (n.d.). Improving the solubility and dissolution of poorly soluble drugs by salt formation and the consequent effect on mechanical properties. Retrieved from [\[Link\]](#)
- MDPI. (2023, October 27). The Use of Cyclodextrin Inclusion Complexes to Increase the Solubility and Pharmacokinetic Profile of Albendazole. Retrieved from [\[Link\]](#)
- Springer. (n.d.). Structural diversity-guided optimization of carbazole derivatives as potential cytotoxic agents. Retrieved from [\[Link\]](#)
- Sivaraman, G., et al. (2022). Exploring the sensing properties of pH-sensitive carbazole-based AIE emitters and their applications in paper strip sensing. *Scientific Reports*, 12, 19379. Retrieved from [\[Link\]](#)
- International Journal of Research in Pharmacy and Pharmaceutical Sciences. (2022, May 24). Co-crystallization: Technique for solubility enhancement. Retrieved from [\[Link\]](#)
- Silberberg, M. (2017). Cyclodextrin as a Drug Carrier Increasing Drug Solubility. *Touro College Journal of Experimental and Theoretical Sciences*, 12. Retrieved from [\[Link\]](#)

- Drug Development & Delivery. (2023, April 21). BIOAVAILABILITY ENHANCEMENT - Solving Low Solubility Challenges to Optimize Drug Delivery Platforms. Retrieved from [[Link](#)]
- Research Journal of Pharmaceutical Dosage Forms and Technology. (n.d.). Drug Dissolution Enhancement by Salt Formation. Retrieved from [[Link](#)]
- Vasconcelos, T., Sarmiento, B., & Costa, P. (2007). Solid dispersions as strategy to improve oral bioavailability of poor water soluble drugs. Drug Discovery Today, 12(23-24), 1068-1075. Retrieved from [[Link](#)]
- MDPI. (2023, June 5). Preparation and Characterization of Carbazole-Based Luminogen with Efficient Emission in Solid and Solution States. Retrieved from [[Link](#)]
- SciSpace. (n.d.). Cyclodextrins and their application in enhancing the solubility, dissolution rate and bioavailability. Retrieved from [[Link](#)]
- YouTube. (2023, April 17). Part1:Particle size reduction, Solid dispersion & Improving solubility of poorly-water soluble drugs. Retrieved from [[Link](#)]
- ResearchGate. (2015, August). Accuracy of calculated pH-dependent aqueous drug solubility. Retrieved from [[Link](#)]
- MDPI. (2023, March 28). Special Issue "Carbazole Derivatives: Latest Advances and Prospects". Retrieved from [[Link](#)]
- International Journal of Pharmaceutical Sciences Review and Research. (2022, June 3). Role of Coformers in Solubility Enhancement of Poorly Soluble Drugs through Cocrystallization. Retrieved from [[Link](#)]
- MDPI. (n.d.). Dissolution Enhancement of Poorly Soluble Drugs. Retrieved from [[Link](#)]
- Journal of the American Chemical Society. (n.d.). [2 + 1] and [2 + 1 + 1] Cyclization: Diversifying Alkenes for Small Carbocycles via Photocatalytically Accessed 1,3-Dielectrophiles. Retrieved from [[Link](#)]
- ResearchGate. (n.d.). Comprehensive solubility study and inter-molecular interactions on fenbendazole dissolved in some aqueous aprotic and protic co-solvent solutions. Retrieved

from [\[Link\]](#)

- National Institutes of Health. (n.d.). Electroactive Carbazole-Based Polycyclic Aromatic Hydrocarbons: Synthesis, Photophysical Properties, and Computational Studies. Retrieved from [\[Link\]](#)

Need Custom Synthesis?

BenchChem offers custom synthesis for rare earth carbides and specific isotopic labeling.

Email: info@benchchem.com or [Request Quote Online](#).

Sources

- [1. mdpi.com \[mdpi.com\]](#)
- [2. researchgate.net \[researchgate.net\]](#)
- [3. Design, synthesis, molecular docking and biological evaluation of new carbazole derivatives as anticancer, and antioxidant agents - PMC \[pmc.ncbi.nlm.nih.gov\]](#)
- [4. solubilityofthings.com \[solubilityofthings.com\]](#)
- [5. Impact of Functional Groups in Organic Chemistry on Pharmaceutical Development - Rechem \[rechemchemicals.com\]](#)
- [6. mdpi.com \[mdpi.com\]](#)
- [7. Exploring the sensing properties of pH-sensitive carbazole-based AIE emitters and their applications in paper strip sensing - PMC \[pmc.ncbi.nlm.nih.gov\]](#)
- [8. Synthesis of benzo\[a \]carbazole derivatives via intramolecular cyclization using Brønsted acidic carbonaceous material as the catalyst - RSC Advances \(RSC Publishing\) DOI:10.1039/D3RA04943D \[pubs.rsc.org\]](#)
- [9. researchgate.net \[researchgate.net\]](#)
- [10. ascendiacdmo.com \[ascendiacdmo.com\]](#)
- [11. pH-Dependent Solubility and Dissolution Behavior of Carvedilol—Case Example of a Weakly Basic BCS Class II Drug - PMC \[pmc.ncbi.nlm.nih.gov\]](#)
- [12. Salt formation to improve drug solubility - PubMed \[pubmed.ncbi.nlm.nih.gov\]](#)
- [13. rjpdf.com \[rjpdf.com\]](#)
- [14. research.aston.ac.uk \[research.aston.ac.uk\]](#)

- [15. mdpi.com \[mdpi.com\]](#)
- [16. researchgate.net \[researchgate.net\]](#)
- [17. globalresearchonline.net \[globalresearchonline.net\]](#)
- [18. mdpi.com \[mdpi.com\]](#)
- [19. Cyclodextrins: Enhancing Drug Delivery, Solubility and Bioavailability for Modern Therapeutics - PMC \[pmc.ncbi.nlm.nih.gov\]](#)
- [20. mdpi.com \[mdpi.com\]](#)
- [21. touroscholar.touro.edu \[touroscholar.touro.edu\]](#)
- [22. scispace.com \[scispace.com\]](#)
- [23. researchgate.net \[researchgate.net\]](#)
- [24. japsonline.com \[japsonline.com\]](#)
- [25. Formulation Strategies for Poorly Soluble Drugs \[worldpharmatoday.com\]](#)
- [26. Overview of the Manufacturing Methods of Solid Dispersion Technology for Improving the Solubility of Poorly Water-Soluble Drugs and Application to Anticancer Drugs - PMC \[pmc.ncbi.nlm.nih.gov\]](#)
- [27. nbinno.com \[nbinno.com\]](#)
- [28. Novel carbazole sulfonamide derivatives of antitumor agent: Synthesis, antiproliferative activity and aqueous solubility - PubMed \[pubmed.ncbi.nlm.nih.gov\]](#)
- [29. merckmillipore.com \[merckmillipore.com\]](#)
- To cite this document: BenchChem. [Technical Support Center: Overcoming Solubility Challenges of Functionalized Carbazoles]. BenchChem, [2026]. [Online PDF]. Available at: [<https://www.benchchem.com/product/b1590146/docs#technical-support-center-overcoming-solubility-challenges-of-functionalized-carbazoles>]

Disclaimer & Data Validity:

The information provided in this document is for Research Use Only (RUO) and is strictly not intended for diagnostic or therapeutic procedures. While BenchChem strives to provide accurate protocols, we make no warranties, express or implied, regarding the fitness of this product for every specific experimental setup.

Technical Support: The protocols provided are for reference purposes. Unsure if this reagent suits your experiment?

Need Industrial/Bulk Grade? [Request Custom Synthesis Quote](#)

BenchChem

Our mission is to be the trusted global source of essential and advanced chemicals, empowering scientists and researchers to drive progress in science and industry.

Contact

Address: 3281 E Guasti Rd
Ontario, CA 91761, United States
Phone: (601) 213-4426
Email: info@benchchem.com

[Contact our Ph.D. Support Team for a compatibility check](#)