

Comprehensive Analytical Profiling of 2-(3-Nitrophenyl)acetaldehyde

Author: BenchChem Technical Support Team. **Date:** May 2026

Compound of Interest

Compound Name: 2-(3-Nitrophenyl)acetaldehyde

CAS No.: 66146-33-6

Cat. No.: B1589022

[Get Quote](#)

Application Note & Method Development Guide

Executive Summary

This guide details the analytical characterization of **2-(3-nitrophenyl)acetaldehyde** (3-NPA), a critical intermediate in the synthesis of indole-based pharmaceuticals and phenethylamine derivatives.

The Analytical Challenge: Unlike stable aromatic aldehydes (e.g., benzaldehyde), phenylacetaldehydes are chemically labile. They are prone to:

- Oxidation: Rapid conversion to 2-(3-nitrophenyl)acetic acid upon air exposure.
- Enolization & Polymerization: Formation of trimers or aldol condensation products under basic or high-temperature conditions.

Scope: This protocol provides two distinct workflows:

- High-Fidelity HPLC-UV: For purity assay and quantification of the acid impurity.

- GC-MS: For structural confirmation and volatile impurity profiling, utilizing a derivatization strategy to ensure thermal stability.

Chemical Context & Stability

Understanding the degradation pathways is essential for accurate data interpretation.

Target Analyte: **2-(3-Nitrophenyl)acetaldehyde**[1]

- MW: 165.15 g/mol [1][2][3]
- Boiling Point: ~165°C (Predicted)
- Solubility: Soluble in Acetonitrile (ACN), Methanol (MeOH), Dichloromethane (DCM). Poorly soluble in water.

Degradation Pathway Diagram

The following diagram illustrates the critical stability issues that dictate sample preparation.

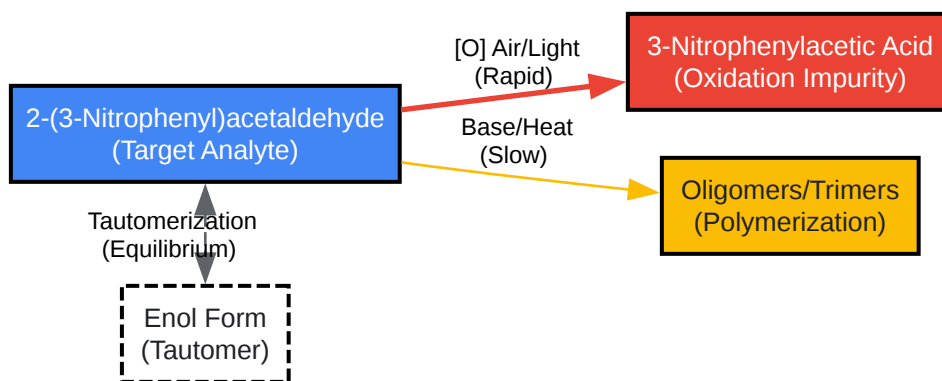

[Click to download full resolution via product page](#)

Figure 1: Primary degradation pathways. Note the rapid oxidation to the carboxylic acid, necessitating fresh sample preparation and acidic mobile phases.

Sample Preparation Protocols

Trustworthiness Principle: Standard solutions must be prepared immediately before analysis to prevent "ghost" peaks from oxidation.

Protocol A: Direct Dilution (HPLC & GC-Direct)

Best for: Rapid purity checks of fresh synthesis batches.

- Weighing: Weigh 10 mg of 3-NPA into a 20 mL amber glass vial.
- Dissolution: Dissolve in 10 mL Acetonitrile (HPLC Grade).
 - Note: Do not use Methanol for GC analysis without derivatization, as hemiacetals may form in the injector.
- Filtration: Filter through a 0.22 μ m PTFE syringe filter.
- Storage: Analyze within 4 hours. Store at 4°C in the dark.

Protocol B: Oxime Derivatization (GC-MS Recommended)

Best for: Precise quantification and preventing thermal degradation in the GC inlet.

- Reagent: Prepare a 20 mg/mL solution of Methoxyamine Hydrochloride in Pyridine.
- Reaction: Mix 100 μ L of Sample (from Protocol A) with 100 μ L of Reagent.
- Incubation: Heat at 60°C for 30 minutes.
- Quench: Dilute with 800 μ L of Ethyl Acetate.
- Mechanism: Converts the thermally unstable aldehyde into a stable O-methyloxime derivative.

HPLC-UV Methodology

This method utilizes a "Generic Gradient" optimized for polar aromatic compounds. The use of an acidic mobile phase is mandatory to suppress the ionization of the acid impurity (3-nitrophenylacetic acid), ensuring it retains on the column and separates from the aldehyde.

Instrument Parameters

Parameter	Setting
Column	Agilent ZORBAX Eclipse Plus C18 (4.6 x 100 mm, 3.5 µm) or equivalent
Mobile Phase A	Water + 0.1% Formic Acid (pH ~2.7)
Mobile Phase B	Acetonitrile (ACN) + 0.1% Formic Acid
Flow Rate	1.0 mL/min
Column Temp	30°C
Injection Vol	5 µL
Detection	UV @ 254 nm (Primary), 210 nm (Secondary)

Gradient Table

Time (min)	% A (Water)	% B (ACN)	Event
0.0	90	10	Equilibration
2.0	90	10	Hold (Elute polar salts)
12.0	10	90	Linear Gradient
15.0	10	90	Wash
15.1	90	10	Re-equilibration

Expected Elution Order & System Suitability

Based on polarity (RP-C18 interaction):

- 3-Nitrophenylacetic Acid (Impurity): ~5.5 - 6.5 min (Most polar due to -COOH).
- 2-(3-Nitrophenyl)ethanol (Precursor): ~7.0 - 8.0 min.
- **2-(3-Nitrophenyl)acetaldehyde (Target): ~8.5 - 9.5 min.**
- Dimers/Oligomers: >12 min.

Acceptance Criteria:

- Resolution (Rs) between Acid and Aldehyde: > 2.0.
- Tailing Factor (Aldehyde): < 1.5 (Acidic mobile phase is critical here).

GC-MS Methodology

GC-MS provides structural confirmation. While direct injection is possible, the aldehyde functionality can degrade to the acid or lose CO in the hot injector.

Method A: Direct Injection (Qualitative)

- Column: DB-5MS or HP-5MS (30 m x 0.25 mm x 0.25 μ m).
- Carrier Gas: Helium @ 1.0 mL/min (Constant Flow).
- Inlet: Split 20:1, 200°C (Keep temp low to minimize degradation).
- Oven Program:
 - 50°C (hold 1 min)
 - Ramp 15°C/min to 280°C
 - Hold 3 min.

Method B: Derivatized Analysis (Quantitative)[4]

- Analyte: **2-(3-nitrophenyl)acetaldehyde O-methyloxime**.
- Inlet: 250°C (Derivative is stable).
- Oven Program: Same as above.
- Note: Oxime formation results in two peaks (Syn and Anti isomers). Sum the areas of both peaks for quantification.

Mass Spectrum Interpretation (EI Source, 70 eV)

Target: **2-(3-Nitrophenyl)acetaldehyde** (Direct Injection)

m/z	Ion Type	Interpretation
165	[M] ⁺	Molecular Ion (Weak intensity).
136	[M - CHO] ⁺	Base Peak (Often). Loss of formyl radical. Formation of nitrobenzyl cation.
119	[M - NO ₂] ⁺	Loss of nitro group (Common in nitro-aromatics).

| 90 | [C₇H₆]⁺ | Tropylium-like ion (derived from benzyl fragment). |

Analytical Workflow Diagram

This flowchart summarizes the decision-making process for analyzing 3-NPA.

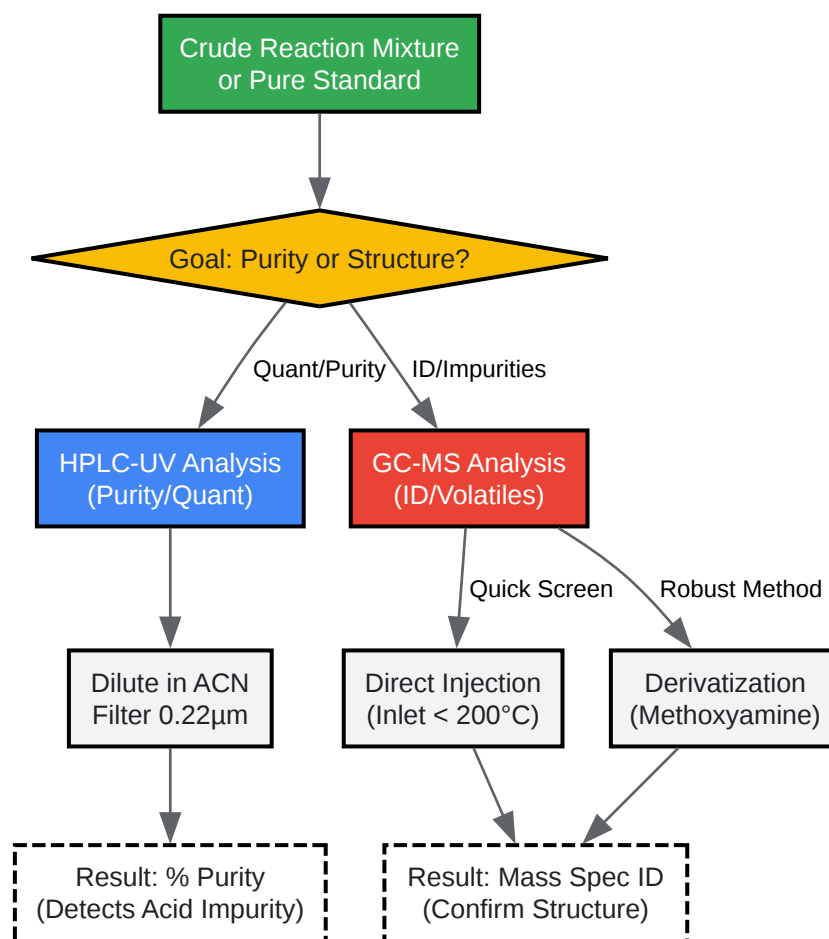

[Click to download full resolution via product page](#)

Figure 2: Decision matrix for selecting the appropriate analytical technique based on research goals.

References

- PubChem. (2025).[1][3] **2-(3-Nitrophenyl)acetaldehyde** Compound Summary. National Library of Medicine. [\[Link\]](#)
- SIELC Technologies. (n.d.). Separation of Phenylacetaldehyde on Newcrom R1 HPLC column. [\[Link\]](#)
- Agilent Technologies. (2020). Analysis of Pharmacologically Relevant Compounds using GC/MSD. [\[Link\]](#)

- MDPI. (2021). Bioanalytical and Mass Spectrometric Methods for Aldehyde Profiling. Molecules. [[Link](#)][2][4][5][6][7][8][9][10][11]

Need Custom Synthesis?

BenchChem offers custom synthesis for rare earth carbides and specific isotopic labeling.

Email: info@benchchem.com or [Request Quote Online](#).

Sources

- 1. 2-(3-Nitrophenyl)acetaldehyde | C₈H₇NO₃ | CID 11528408 - PubChem [pubchem.ncbi.nlm.nih.gov]
- 2. [benchchem.com](https://www.benchchem.com) [[benchchem.com](https://www.benchchem.com)]
- 3. (4-Nitrophenyl)acetaldehyde | C₈H₇NO₃ | CID 11744988 - PubChem [pubchem.ncbi.nlm.nih.gov]
- 4. [mdpi.com](https://www.mdpi.com) [[mdpi.com](https://www.mdpi.com)]
- 5. [researchgate.net](https://www.researchgate.net) [[researchgate.net](https://www.researchgate.net)]
- 6. Separation of Phenylacetaldehyde on Newcrom R1 HPLC column | SIELC Technologies [[sielc.com](https://www.sielc.com)]
- 7. pdf.benchchem.com [pdf.benchchem.com]
- 8. [tentamus.com](https://www.tentamus.com) [[tentamus.com](https://www.tentamus.com)]
- 9. [researchgate.net](https://www.researchgate.net) [[researchgate.net](https://www.researchgate.net)]
- 10. Study on the Mechanism of Phenylacetaldehyde Formation in a Chinese Water Chestnut-Based Medium during the Steaming Process - PMC [[pmc.ncbi.nlm.nih.gov](https://pubmed.ncbi.nlm.nih.gov)]
- 11. Improvement of Soluble Expression, Stability, and Activity of Acetaldehyde Lyase by Elastin-like Polypeptides Fusion for Acetoin Production from Acetaldehyde [[mdpi.com](https://www.mdpi.com)]
- To cite this document: BenchChem. [Comprehensive Analytical Profiling of 2-(3-Nitrophenyl)acetaldehyde]. BenchChem, [2026]. [Online PDF]. Available at: [<https://www.benchchem.com/product/b1589022/docs#comprehensive-analytical-profiling-of-2-3-nitrophenyl-acetaldehyde>]

Disclaimer & Data Validity:

The information provided in this document is for Research Use Only (RUO) and is strictly not intended for diagnostic or therapeutic procedures. While BenchChem strives to provide accurate protocols, we make no warranties, express or implied, regarding the fitness of this product for every specific experimental setup.

Technical Support: The protocols provided are for reference purposes. Unsure if this reagent suits your experiment?

Need Industrial/Bulk Grade? [Request Custom Synthesis Quote](#)

BenchChem

Our mission is to be the trusted global source of essential and advanced chemicals, empowering scientists and researchers to drive progress in science and industry.

Contact

Address: 3281 E Guasti Rd
Ontario, CA 91761, United States
Phone: (601) 213-4426
Email: info@benchchem.com

[Contact our Ph.D. Support Team for a compatibility check](#)