

# Application Notes & Protocols for Reactions with Sodium Propan-2-olate

**Author:** BenchChem Technical Support Team. **Date:** May 2026

## Compound of Interest

Compound Name: Sodium propan-2-olate

CAS No.: 683-60-3

Cat. No.: B1589648

[Get Quote](#)

## Abstract

This document provides a comprehensive guide for researchers, scientists, and drug development professionals on the effective and safe use of **sodium propan-2-olate** (sodium isopropoxide). As a potent, non-nucleophilic base with moderate steric hindrance, **sodium propan-2-olate** is a versatile and critical reagent in modern organic synthesis. These application notes delve into its fundamental properties, safety protocols, in-situ preparation, and detailed experimental setups for key transformations, including the Williamson ether synthesis and base-catalyzed transesterification. The causality behind experimental choices is explained, ensuring protocols are scientifically robust and reproducible.

## Introduction: The Role of Sodium Propan-2-olate in Organic Synthesis

**Sodium propan-2-olate**, commonly known as sodium isopropoxide, is an alkoxide salt widely employed in organic chemistry.<sup>[1][2]</sup> Its utility stems from its character as a strong base and a competent nucleophile, enabling a variety of chemical transformations such as condensations, eliminations, and alkylations.<sup>[1]</sup> It is particularly valuable when a base stronger than hydroxides

is required, but a less sterically demanding one than tert-butoxides is preferred. This guide provides the foundational knowledge and practical protocols necessary to successfully and safely integrate **sodium propan-2-olate** into synthetic workflows.

## Reagent Profile and Safety Mandates

### Physicochemical Data

A clear understanding of the reagent's physical properties is paramount for proper handling and reaction setup.

Property	Value	Source(s)
Synonyms	Sodium isopropoxide, Sodium 2-propoxide	[1][3]
CAS Number	683-60-3	[1][4]
Molecular Formula	C <sub>3</sub> H <sub>7</sub> NaO	[1][5]
Molecular Weight	82.08 g/mol	[5]
Appearance	White to yellowish crystalline solid/powder	[6][7]
Melting Point	70-75 °C	[2][4][6]
Solubility	Soluble in tetrahydrofuran; reacts violently with water.	[2][3][7]
Sensitivity	Highly sensitive to moisture and air.	[2][6]

### Critical Safety and Handling Protocols

**Sodium propan-2-olate** is a hazardous chemical that demands strict adherence to safety protocols. It is flammable, corrosive, and reacts violently with water.[3][6][7]

- Inert Atmosphere Handling: Due to its high sensitivity to moisture and air, **sodium propan-2-olate** must be handled and stored under an inert atmosphere (e.g., nitrogen or argon).[5][6]

[8] Exposure to atmospheric moisture leads to rapid decomposition into sodium hydroxide and isopropanol, diminishing its efficacy and creating safety hazards.[7][8]

- Personal Protective Equipment (PPE): Always wear a flame-resistant lab coat, chemical safety goggles (EN 166 standard), and nitrile or neoprene gloves.[6][8][9] All manipulations should be conducted within a certified chemical fume hood.[9]
- Fire Safety: Use Class D fire extinguishers (dry powder, sand). DO NOT use water, foam, or carbon dioxide, as these will react violently with the alkoxide.[6][10]
- Storage: Store in a tightly sealed container in a cool, dry, and well-ventilated area designated for corrosive and flammable materials, away from incompatible materials like oxidizing agents and water.[8][9][10]
- Spill Management: In case of a small spill, carefully sweep up the solid material, avoiding dust formation, and place it into a suitable container for disposal. Do not expose the spill to water.[9][10]

## In-Situ Preparation of Sodium Propan-2-olate

While commercially available, preparing **sodium propan-2-olate** fresh (in situ) from dry isopropanol and a sodium source (sodium metal or sodium hydride) is often preferred to ensure maximum reactivity.

### Protocol 3.1: Preparation from Sodium Hydride

This method is generally safer than using sodium metal as it avoids handling highly reactive metallic sodium.

Materials:

- Sodium hydride (NaH), 60% dispersion in mineral oil
- Anhydrous isopropanol
- Anhydrous tetrahydrofuran (THF) or isopropanol (as reaction solvent)
- Three-neck round-bottom flask with a magnetic stir bar

- Septa, nitrogen/argon inlet, and bubbler
- Addition funnel

Procedure:

- Setup: Assemble the glassware and flame-dry it under vacuum, then allow it to cool to room temperature under a positive pressure of nitrogen or argon.
- NaH Preparation: In the flask, suspend the required amount of NaH (60% dispersion) in anhydrous THF. If desired, the mineral oil can be removed by washing the NaH dispersion with anhydrous hexanes under an inert atmosphere, allowing the NaH to settle, and decanting the hexanes.
- Reaction: Cool the NaH suspension to 0 °C using an ice bath.
- Addition of Isopropanol: Slowly add an equimolar amount of anhydrous isopropanol dropwise via the addition funnel. Vigorous hydrogen gas evolution will occur. The rate of addition must be controlled to prevent excessive foaming and a runaway reaction.
- Completion: Once the addition is complete, remove the ice bath and allow the mixture to stir at room temperature for 1-2 hours, or until hydrogen evolution ceases. The resulting solution/slurry of **sodium propan-2-olate** is now ready for use.[\[11\]](#)

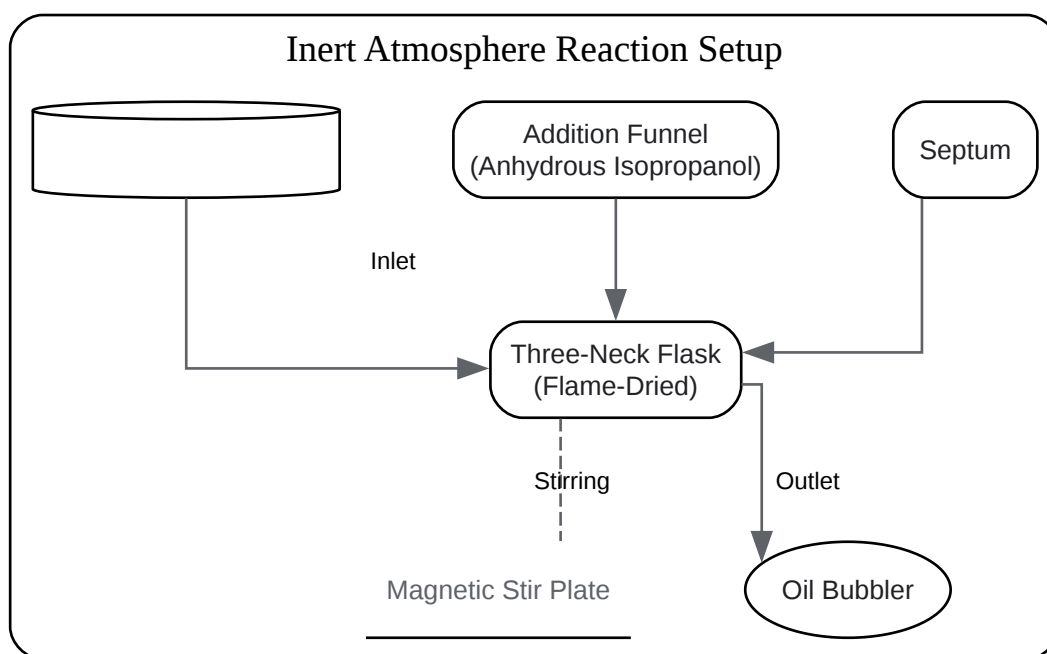

[Click to download full resolution via product page](#)

Caption: General setup for reactions requiring an inert atmosphere.

## Application I: The Williamson Ether Synthesis

The Williamson ether synthesis is a robust  $S_N2$  reaction for preparing symmetrical and unsymmetrical ethers.<sup>[12]</sup> **Sodium propan-2-olate** serves as the base to deprotonate an alcohol (or is used directly as the nucleophilic alkoxide) to react with a primary alkyl halide.

### Mechanistic Considerations

The reaction proceeds via a backside attack of the alkoxide nucleophile on the carbon atom bearing the leaving group.<sup>[13]</sup>

- **Substrate Choice:** This reaction works best with methyl or primary alkyl halides.<sup>[13]</sup>
- **Competition with Elimination (E2):** With secondary alkyl halides, a competing E2 elimination reaction can become significant, reducing the ether yield. With tertiary alkyl halides, elimination is almost exclusively observed.<sup>[12][13]</sup> Therefore, to synthesize an ether like ethyl isopropyl ether, it is far more efficient to react sodium isopropoxide with ethyl bromide (primary halide) than to react sodium ethoxide with 2-bromopropane (secondary halide).<sup>[12]</sup>

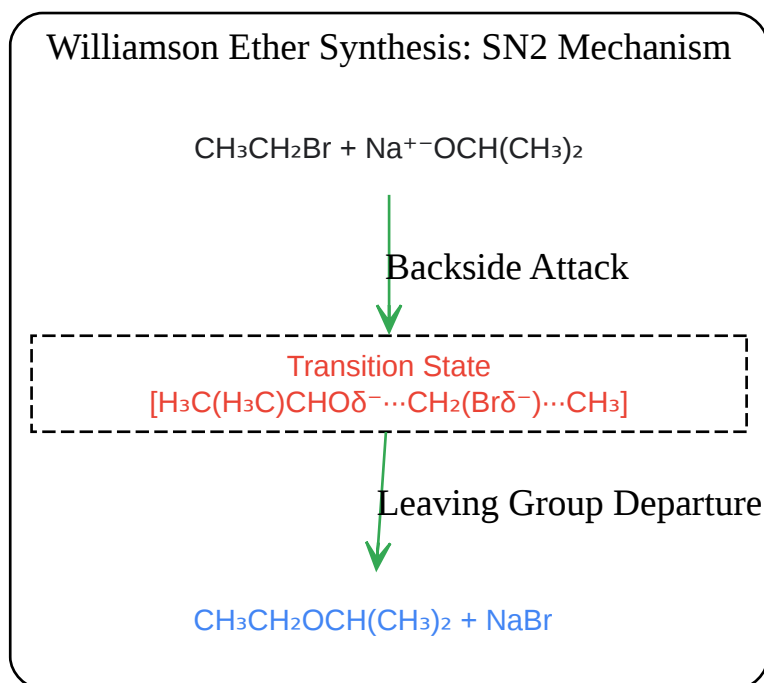

[Click to download full resolution via product page](#)

Caption: SN2 mechanism for the Williamson ether synthesis.

## Protocol 4.2: Synthesis of Ethyl Isopropyl Ether

Materials:

- **Sodium propan-2-olate** (prepared in situ as a ~1M solution in THF or purchased)
- Ethyl bromide (EtBr)
- Anhydrous Tetrahydrofuran (THF)
- Saturated aqueous ammonium chloride (NH<sub>4</sub>Cl)
- Diethyl ether
- Anhydrous magnesium sulfate (MgSO<sub>4</sub>)

Procedure:

- **Reaction Setup:** To a flame-dried, three-neck flask under a nitrogen atmosphere, add the solution of **sodium propan-2-olate** (1.1 equivalents) in anhydrous THF.
- **Substrate Addition:** Cool the solution to 0 °C. Add ethyl bromide (1.0 equivalent) dropwise via syringe.
- **Reaction:** After the addition is complete, allow the reaction to warm to room temperature and stir for 12-18 hours. The formation of a white precipitate (NaBr) is typically observed.
- **Monitoring:** The reaction progress can be monitored by TLC (staining with permanganate) or GC-MS by observing the disappearance of ethyl bromide.
- **Quenching:** Cool the reaction mixture to 0 °C and quench by the slow, dropwise addition of saturated aqueous NH<sub>4</sub>Cl solution.
- **Extraction:** Transfer the mixture to a separatory funnel. Add diethyl ether and water. Separate the layers and extract the aqueous layer twice more with diethyl ether.
- **Washing & Drying:** Combine the organic layers, wash with brine, dry over anhydrous MgSO<sub>4</sub>, filter, and concentrate under reduced pressure to yield the crude product.
- **Purification:** The resulting ethyl isopropyl ether can be purified by simple distillation if necessary.

## Application II: Base-Catalyzed Transesterification

Transesterification is the process of converting one ester to another by exchanging the alkoxy group, a cornerstone reaction in applications like polyester production and biodiesel synthesis. [14] **Sodium propan-2-olate** is an effective catalyst for this transformation.

### Mechanism Overview

The reaction is initiated by the alkoxide, which acts as a nucleophile, attacking the carbonyl carbon of the starting ester.[15][16] This forms a tetrahedral intermediate, which then collapses, eliminating the original alkoxy group to form the new ester.[15] The reaction is an equilibrium process; therefore, using a large excess of the new alcohol is necessary to drive the reaction to completion, following Le Châtelier's principle.[16]

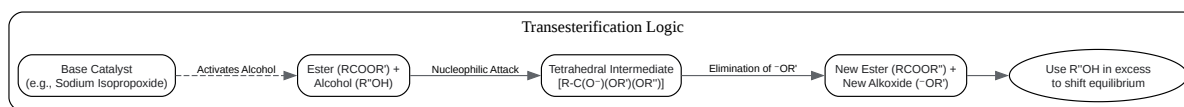

[Click to download full resolution via product page](#)

Caption: Logical flow of base-catalyzed transesterification.

## Protocol 5.2: General Procedure for Transesterification

Materials:

- Starting ester (e.g., methyl benzoate)
- Alcohol solvent (e.g., isopropanol, must be in large excess)
- **Sodium propan-2-olate** (catalytic amount, e.g., 5 mol%)
- Weak acid for neutralization (e.g., acetic acid)

Procedure:

- **Setup:** In a round-bottom flask equipped with a reflux condenser and under a nitrogen atmosphere, dissolve the starting ester (1.0 equivalent) in a large excess of the desired alcohol (e.g., isopropanol, which also acts as the solvent).
- **Catalyst Addition:** Add the catalytic amount of **sodium propan-2-olate** to the solution.
- **Reaction:** Heat the mixture to reflux and maintain for several hours.
- **Monitoring:** Monitor the reaction by GC or  $^1\text{H}$  NMR, observing the disappearance of the starting ester signal and the appearance of the product ester signal.[\[17\]](#)[\[18\]](#)
- **Work-up:** Cool the reaction to room temperature. Neutralize the catalyst by adding a few drops of acetic acid.

- Isolation: Remove the excess alcohol under reduced pressure. Dissolve the residue in a suitable organic solvent (e.g., diethyl ether), wash with water and brine, dry over anhydrous  $\text{Na}_2\text{SO}_4$ , and concentrate to afford the product ester.
- Purification: Purify via distillation or column chromatography as needed.

## Reaction Quenching: A Critical Safety Step

Due to the presence of a highly reactive alkoxide, quenching the reaction mixture must be done with extreme caution to control the exothermic reaction with protic reagents.

### Protocol 6.1: Safe Quenching Procedure

- Cooling: Always cool the reaction flask to 0 °C in an ice-water bath before quenching.[19]
- Initial Quench: Slowly and dropwise, add a less reactive alcohol like isopropanol or ethanol. [19][20] This reacts less vigorously than water. Do this until gas evolution or exotherm subsides.[19]
- Aqueous Addition: Once the initial quench is complete and the reaction is no longer vigorous, slowly add water or an aqueous solution (e.g., saturated  $\text{NH}_4\text{Cl}$  or a weak acid) to fully neutralize any remaining base.[19]
- Safety: Perform all quenching operations in a fume hood, away from flammable materials, and ensure a suitable fire extinguisher is nearby.[21]

## References

- Gelest, Inc. SODIUM ISOPROPOXIDE, 20% in tetrahydrofuran - Safety Data Sheet. [Link]
- Sciencemadness Discussion Board. Safely quenching sodium?. [Link]
- LookChem. Cas 683-60-3, **Sodium propan-2-olate**. [Link]
- Henderson, K. Common Standard Operating Procedure for work with Quenching of pyrophoric substances and waste. [Link]

- University of California, Berkeley. STANDARD OPERATING PROCEDURES FOR QUENCHING SOLVENT DRYING STILL BOTTOMS. [[Link](#)]
- UCLA Department of Chemistry and Biochemistry. Improper Quenching of Sodium. [[Link](#)]
- Chemistry Steps. The Williamson Ether Synthesis. [[Link](#)]
- Sarpong, R. Quenching of Self-Heating Substances and Mixtures. [[Link](#)]
- Symax Laboratories Private Limited. Sodium Isopropoxide. [[Link](#)]
- Fisher Scientific. SAFETY DATA SHEET - Sodium isopropoxide. [[Link](#)]
- University of Missouri–St. Louis. The Williamson Ether Synthesis. [[Link](#)]
- Haz-Map. Sodium isopropoxide - Hazardous Agents. [[Link](#)]
- Master Organic Chemistry. The Williamson Ether Synthesis. [[Link](#)]
- KPU Pressbooks. 1.5 Williamson Ether Synthesis – Organic Chemistry II. [[Link](#)]
- Wikipedia. Transesterification. [[Link](#)]
- Master Organic Chemistry. Transesterification. [[Link](#)]
- University of Windsor. Analytical techniques for reaction monitoring, mechanistic investigations, and metal complex discovery. [[Link](#)]
- Wiley. ANALYTICAL METHODS FOR THERAPEUTIC DRUG MONITORING AND TOXICOLOGY. [[Link](#)]
- Redalyc. ESTERIFICATION AND TRANSESTERIFICATION ASSISTED BY MICROWAVES OF CRUDE PALM OIL. HOMOGENEOUS CATALYSIS. [[Link](#)]
- Frontiers. Estimation of Reaction Rates of Transesterification Pathways. [[Link](#)]
- Chemistry LibreTexts. Transesterification. [[Link](#)]

- LCGC International. Rapid Monitoring of Chemical Reactions Made Possible by Ultrahigh-Performance Liquid Chromatography. [[Link](#)]
- Spectroscopy Online. Seven Essential Steps for In Situ Reaction Monitoring. [[Link](#)]

### Need Custom Synthesis?

BenchChem offers custom synthesis for rare earth carbides and specific isotopic labeling.

Email: [info@benchchem.com](mailto:info@benchchem.com) or [Request Quote Online](#).

## Sources

- 1. Page loading... [[wap.guidechem.com](http://wap.guidechem.com)]
- 2. lookchem.com [[lookchem.com](http://lookchem.com)]
- 3. CAS 683-60-3: Sodium isopropoxide | CymitQuimica [[cymitquimica.com](http://cymitquimica.com)]
- 4. Page loading... [[wap.guidechem.com](http://wap.guidechem.com)]
- 5. Sodium isopropoxide | 683-60-3 | FS180720 | Biosynth [[biosynth.com](http://biosynth.com)]
- 6. fishersci.be [[fishersci.be](http://fishersci.be)]
- 7. Sodium isopropoxide - Hazardous Agents | Haz-Map [[haz-map.com](http://haz-map.com)]
- 8. gelest.com [[gelest.com](http://gelest.com)]
- 9. fishersci.com [[fishersci.com](http://fishersci.com)]
- 10. fishersci.com [[fishersci.com](http://fishersci.com)]
- 11. Sodium propan-2-olate synthesis - chemicalbook [[chemicalbook.com](http://chemicalbook.com)]
- 12. Williamson Ether Synthesis - Chemistry Steps [[chemistrysteps.com](http://chemistrysteps.com)]
- 13. masterorganicchemistry.com [[masterorganicchemistry.com](http://masterorganicchemistry.com)]
- 14. Transesterification - Wikipedia [[en.wikipedia.org](http://en.wikipedia.org)]
- 15. masterorganicchemistry.com [[masterorganicchemistry.com](http://masterorganicchemistry.com)]
- 16. chem.libretexts.org [[chem.libretexts.org](http://chem.libretexts.org)]
- 17. Analytical techniques for reaction monitoring, mechanistic investigations, and metal complex discovery [[dSPACE.library.uvic.ca](http://dSPACE.library.uvic.ca)]
- 18. benchchem.com [[benchchem.com](http://benchchem.com)]

- [19. chemistry.nd.edu](https://chemistry.nd.edu) [[chemistry.nd.edu](https://chemistry.nd.edu)]
- [20. safety.engr.wisc.edu](https://safety.engr.wisc.edu) [[safety.engr.wisc.edu](https://safety.engr.wisc.edu)]
- [21. ehs.uci.edu](https://ehs.uci.edu) [[ehs.uci.edu](https://ehs.uci.edu)]
- To cite this document: BenchChem. [Application Notes & Protocols for Reactions with Sodium Propan-2-olate]. BenchChem, [2026]. [Online PDF]. Available at: [<https://www.benchchem.com/product/b1589648/docs#application-notes-protocols-for-reactions-with-sodium-propan-2-olate>]

### Disclaimer & Data Validity:

The information provided in this document is for Research Use Only (RUO) and is strictly not intended for diagnostic or therapeutic procedures. While BenchChem strives to provide accurate protocols, we make no warranties, express or implied, regarding the fitness of this product for every specific experimental setup.

**Technical Support:** The protocols provided are for reference purposes. Unsure if this reagent suits your experiment?

**Need Industrial/Bulk Grade?** [Request Custom Synthesis Quote](#)

## BenchChem

Our mission is to be the trusted global source of essential and advanced chemicals, empowering scientists and researchers to drive progress in science and industry.

### Contact

Address: 3281 E Guasti Rd  
Ontario, CA 91761, United States  
Phone: (601) 213-4426  
Email: [info@benchchem.com](mailto:info@benchchem.com)

[Contact our Ph.D. Support Team for a compatibility check](#)

