

# Application Note: High-Impact Asymmetric Synthesis of Functionalized Cyclopentane-1-Carboxylic Acids

**Author:** BenchChem Technical Support Team. **Date:** May 2026

## Compound of Interest

Compound Name:	<i>1-carbamoylcyclobutane-1-carboxylic Acid</i>
CAS No.:	845621-11-6
Cat. No.:	B1589009

[Get Quote](#)

## Executive Summary & Strategic Importance

The functionalized cyclopentane-1-carboxylic acid scaffold is a privileged motif in modern medicinal chemistry, serving as the pharmacophore core for neuraminidase inhibitors (e.g., Peramivir), NK1 antagonists, and conformationally restricted

-amino acids (e.g., Cispentacin).

Achieving high enantiomeric excess (ee) and diastereomeric ratio (dr) on this ring system is historically challenging due to the flexibility of the cyclopentane envelope and the difficulty in controlling remote stereocenters. This guide moves beyond classical resolution methods, presenting two field-proven, catalytic asymmetric protocols that offer superior atom economy and scalability.

## Strategic Selection Guide

Feature	Method A: Desymmetrization	Method B: De Novo Domino Assembly
Primary Mechanism	Organocatalytic Ring Opening of meso-Anhydrides	Organocatalytic Michael-Aldol Cascade
Starting Material	cis-Cyclopentane-1,2-dicarboxylic anhydride	Linear precursors (Enals + Nitroalkenes/Esters)
Complexity	Sets 2 stereocenters; ideal for core scaffolds	Sets 3-5 stereocenters in one pot
Scalability	High (kg-scale ready)	Moderate (requires precise kinetics)
Key Application	-Amino acids, simple chiral building blocks	Highly substituted cores (e.g., Prostaglandin analogs)

## Core Protocol A: Asymmetric Desymmetrization of meso-Anhydrides

Objective: Synthesis of (1S,2R)-2-(methoxycarbonyl)cyclopentane-1-carboxylic acid with >95% ee.

This method utilizes a modified Cinchona alkaloid to differentiate the enantiotopic carbonyl groups of a meso-anhydride. It is the industry standard for generating chiral cyclopentane-1-carboxylic acid derivatives due to its operational simplicity and high yield.

### Mechanistic Insight

The reaction proceeds via a general base-catalyzed mechanism where the quinuclidine nitrogen of the catalyst activates the nucleophile (methanol). The catalyst's chiral pocket imposes strict steric constraints, directing the attack preferentially to one carbonyl group.

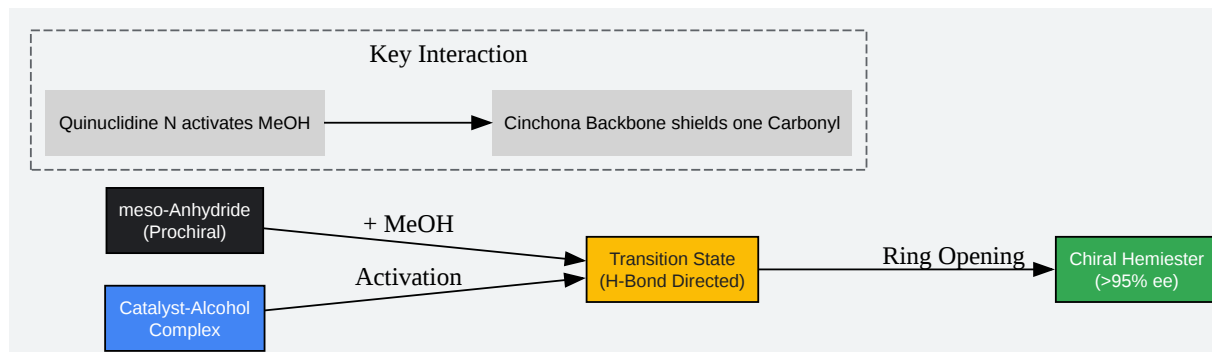

[Click to download full resolution via product page](#)

Figure 1: Mechanistic flow of the cinchona-alkaloid catalyzed desymmetrization.

## Experimental Protocol

### Reagents:

- Substrate: cis-Cyclopentane-1,2-dicarboxylic anhydride (1.0 equiv)
- Nucleophile: Methanol (10.0 equiv)
- Catalyst: (DHQD)<sub>2</sub>AQN (Hydroquinidine (anthraquinone-1,4-diyl)diether) (5 mol%)
- Solvent: Methyl tert-butyl ether (MTBE) or Toluene (anhydrous)

### Step-by-Step Workflow:

- Preparation: Flame-dry a 100 mL round-bottom flask equipped with a magnetic stir bar and cool under argon.
- Charging: Add cis-cyclopentane-1,2-dicarboxylic anhydride (1.40 g, 10 mmol) and (DHQD)<sub>2</sub>AQN (43 mg, 0.05 mmol).
- Solvation: Add anhydrous MTBE (50 mL). Cool the mixture to -20 °C using a cryostat or CCl<sub>4</sub>/dry ice bath. Critical: Lower temperature significantly enhances enantioselectivity.

- Initiation: Add Methanol (4.0 mL, 100 mmol) dropwise over 10 minutes to prevent localized exotherms.
- Incubation: Stir at -20 °C for 24–48 hours. Monitor conversion by TLC (Hexane:EtOAc 1:1) or <sup>1</sup>H NMR (disappearance of anhydride peak at ~3.2 ppm).
- Quench & Workup:
  - Concentrate the reaction mixture in vacuo to remove excess methanol.
  - Dissolve residue in EtOAc (30 mL) and wash with 1N HCl (2 x 15 mL) to remove the catalyst. Note: The aqueous layer contains the catalyst, which can be recovered by basification (pH 10) and extraction.
  - Wash the organic layer with brine, dry over Na<sub>2</sub>SO<sub>4</sub>, and concentrate.
- Purification: The crude hemiester is typically pure enough for downstream applications. If necessary, purify via flash chromatography on silica gel (DCM:MeOH 95:5).

#### Expected Results:

- Yield: 90–98%
- ee: 93–98% (Determined by Chiral HPLC)

## Core Protocol B: De Novo Organocatalytic Domino Assembly

Objective: One-pot synthesis of highly substituted cyclopentanes via Triple Michael/Aldol cascade.

For targets requiring multiple stereocenters (e.g., prostaglandin analogs), desymmetrization is insufficient. This protocol builds the ring from linear precursors.

## Experimental Protocol

Reagents:

- Substrate A:
  - unsaturated aldehyde (e.g., trans-cinnamaldehyde) (1.0 equiv)
- Substrate B: Nitroalkene or
  - ketoester (1.0 equiv)
- Catalyst: Diphenylprolinol silyl ether (Jørgensen-Hayashi Catalyst) (10 mol%)
- Additives: Benzoic acid (10 mol%) to accelerate iminium formation.

#### Step-by-Step Workflow:

- Setup: In a vial, dissolve the catalyst (10 mol%) and benzoic acid (10 mol%) in Toluene (0.5 M concentration relative to substrate).
- Addition: Add the nitroalkene (1.0 equiv). Stir at ambient temperature for 5 minutes.
- Cascade Initiation: Add the
  - unsaturated aldehyde (1.2 equiv).
- Reaction: Stir at room temperature for 12–24 hours. The reaction proceeds via a Michael addition followed by an intramolecular Henry (nitro-aldol) or Michael reaction.
- Workup: Quench with saturated  $\text{NH}_4\text{Cl}$ . Extract with DCM.
- Purification: Flash chromatography (Hexane:EtOAc).

## Analytical Validation & Quality Control

Trustworthiness in asymmetric synthesis relies on rigorous validation of stereochemical purity.

### Chiral HPLC Method (for Method A Product)

- Column: Chiralpak AD-H or OD-H (4.6 mm x 250 mm, 5  $\mu\text{m}$ ).
- Mobile Phase: Hexane : Isopropanol (90:10) with 0.1% TFA (TFA is critical to sharpen the peak of the carboxylic acid).

- Flow Rate: 1.0 mL/min.
- Detection: UV @ 210 nm.
- Retention Times (Approximate):
  - (1R,2S)-isomer: 8.5 min
  - (1S,2R)-isomer: 11.2 min

## NMR Validation

- $^1\text{H}$  NMR (400 MHz,  $\text{CDCl}_3$ ): Look for the methyl ester singlet at 3.68 ppm. The methine protons on the ring will show distinct splitting patterns (multiplets) at 3.0–3.2 ppm indicative of cis vs trans coupling constants.

## Troubleshooting & Optimization

Issue	Root Cause	Corrective Action
Low ee (<90%)	Temperature too high	Ensure cryostat maintains -20 °C or lower.
Low ee (<90%)	Wet solvent	Use freshly distilled or molecular sieve-dried MTBE. Water hydrolyzes the anhydride non-selectively.
Low Conversion	Catalyst poisoning	Ensure starting anhydride is free of hydrolyzed diacid. Recrystallize anhydride if necessary.
Poor Peak Shape (HPLC)	Acidic analyte	Add 0.1% TFA or Formic Acid to the mobile phase to suppress ionization of the carboxylic acid.

## References

- Organocatalytic Triple Michael Domino Reaction
  - Title: Asymmetric Synthesis of Fully Substituted Cyclopentane-Oxindoles through an Organoc
  - Source: NIH / PubMed Central.
  - URL:[\[Link\]](#)
- Desymmetrization of meso-Anhydrides (Cinchona Alkaloids)
  - Title: A Highly Enantioselective Catalytic Desymmetrization of Cyclic Anhydrides with Modified Cinchona Alkaloids.
  - Source: Journal of the American Chemical Society (JACS).[1]
  - URL:[\[Link\]](#)
- Synthesis of Cispentacin
  - Title: Asymmetric Synthesis of (-)-(1R,2S)-Cispentacin and Related cis- and trans-2-Amino Cyclopentane-1-carboxylic Acids.[2][3]
  - Source: Royal Society of Chemistry (Perkin Trans. 1).
  - URL:[\[Link\]](#)
- Drug Discovery Applications (Neuraminidase Inhibitors)
  - Title: Systematic Structure-Based Design and Stereoselective Synthesis of Novel Multisubstituted Cyclopentane Derivatives with Potent Antiinfluenza Activity.
  - Source: Journal of Medicinal Chemistry.
  - URL:[\[Link\]](#)
- Desymmetrization via CDC
  - Title: Desymmetrization of cyclopentenediones via organocatalytic CDC with pyrazoles.[4]

- Source: ResearchGate.[4][5]
- URL:[[Link](#)]

### Need Custom Synthesis?

BenchChem offers custom synthesis for rare earth carbides and specific isotopic labeling.

Email: [info@benchchem.com](mailto:info@benchchem.com) or [Request Quote Online](#).

## Sources

- 1. [pubs.acs.org](https://pubs.acs.org) [[pubs.acs.org](https://pubs.acs.org)]
- 2. Asymmetric synthesis of (–)-(1R,2S)-cispentacin and related cis- and trans-2-amino cyclopentane- and cyclohexane-1-carboxylic acids - Journal of the Chemical Society, Perkin Transactions 1 (RSC Publishing) [[pubs.rsc.org](https://pubs.rsc.org)]
- 3. Asymmetric synthesis of (–)-(1R,2S)-cispentacin and related cis- and trans-2-amino cyclopentane- and cyclohexane-1-carboxylic acids - Journal of the Chemical Society, Perkin Transactions 1 (RSC Publishing) [[pubs.rsc.org](https://pubs.rsc.org)]
- 4. [researchgate.net](https://researchgate.net) [[researchgate.net](https://researchgate.net)]
- 5. [researchgate.net](https://researchgate.net) [[researchgate.net](https://researchgate.net)]
- To cite this document: BenchChem. [Application Note: High-Impact Asymmetric Synthesis of Functionalized Cyclopentane-1-Carboxylic Acids]. BenchChem, [2026]. [Online PDF]. Available at: [<https://www.benchchem.com/product/b1589009/docs#application-note-high-impact-asymmetric-synthesis-of-functionalized-cyclopentane-1-carboxylic-acids>]

---

### Disclaimer & Data Validity:

The information provided in this document is for Research Use Only (RUO) and is strictly not intended for diagnostic or therapeutic procedures. While BenchChem strives to provide accurate protocols, we make no warranties, express or implied, regarding the fitness of this product for every specific experimental setup.

**Technical Support:** The protocols provided are for reference purposes. Unsure if this reagent suits your experiment?

**Need Industrial/Bulk Grade?** [Request Custom Synthesis Quote](#)

## BenchChem

Our mission is to be the trusted global source of essential and advanced chemicals, empowering scientists and researchers to drive progress in science and industry.

### Contact

Address: 3281 E Guasti Rd  
Ontario, CA 91761, United States  
Phone: (601) 213-4426  
Email: [info@benchchem.com](mailto:info@benchchem.com)

[Contact our Ph.D. Support Team for a compatibility check](#)