

An In-Depth Technical Guide to 2-Chloro-3-iodo-5-nitropyridine

Author: BenchChem Technical Support Team. **Date:** February 2026

Compound of Interest

Compound Name: 2-Chloro-3-iodo-5-nitropyridine

CAS No.: 25391-60-0

Cat. No.: B1589499

[Get Quote](#)

Abstract

2-Chloro-3-iodo-5-nitropyridine is a pivotal, multi-functionalized heterocyclic building block in modern organic synthesis. Its strategic arrangement of three distinct functional groups—a reactive iodine, a less labile chlorine, and an electron-withdrawing nitro group—on a pyridine scaffold offers chemists a powerful tool for constructing complex molecular architectures. The inherent electronic and steric properties of this reagent allow for highly selective, sequential transformations, making it an invaluable intermediate in the fields of medicinal chemistry, agrochemicals, and materials science. This guide provides a comprehensive overview of its core chemical properties, delves into its nuanced reactivity, presents validated experimental protocols, and outlines essential safety and handling procedures.

Core Physicochemical and Spectroscopic Profile

Understanding the fundamental properties of a reagent is the bedrock of its effective application. **2-Chloro-3-iodo-5-nitropyridine** is typically a stable, off-white to yellow crystalline solid at room temperature.^{[1][2]} Its key identifiers and properties are summarized below.

Physical and Chemical Properties

| Property | Value | Source(s) |
|-------------------|----------------------------------------------------------------|-----------|
| IUPAC Name | 2-Chloro-3-iodo-5-nitropyridine | [3] |
| CAS Number | 25391-60-0 | [4] |
| Molecular Formula | C ₅ H ₂ ClIN ₂ O ₂ | [4] |
| Molecular Weight | 284.44 g/mol | [4] |
| Appearance | Off-white to gray/yellow solid | [1][2] |
| Melting Point | 102-106 °C | [2][4] |
| Solubility | Soluble in Toluene, DMF, Dichloromethane | [2][5] |
| Storage | Store under inert gas (Nitrogen/Argon) at 2–8 °C | [2] |

Spectroscopic Signature

The spectroscopic profile is essential for reaction monitoring and final product confirmation.

- ¹H NMR (300 MHz, CDCl₃): The proton NMR spectrum is characterized by two distinct singlets in the aromatic region, corresponding to the two protons on the pyridine ring. The significant downfield shift is a direct consequence of the powerful deshielding effects of the adjacent nitro group and the electronegative halogen atoms.
 - δ 9.19 (s, 1H)
 - δ 8.90 (s, 1H)[2]
- ¹³C NMR: While specific literature data is sparse, the chemical shifts can be predicted. The carbon bearing the iodine (C3) would be significantly shielded due to the heavy atom effect, while the carbons attached to the chloro (C2) and nitro (C5) groups, along with the carbon ortho to the nitro group (C6), would be deshielded.
- Mass Spectrometry (MS): Electron Ionization (EI) would likely show a prominent molecular ion peak (m/z = 284/286 for ³⁵Cl/³⁷Cl isotopes) and characteristic fragmentation patterns

involving the loss of I, NO₂, and Cl radicals.[6]

- Infrared (IR) Spectroscopy: Key vibrational bands would include strong asymmetric and symmetric stretches for the nitro group (typically ~1530 cm⁻¹ and ~1350 cm⁻¹), C=N and C=C stretches for the pyridine ring (~1600-1400 cm⁻¹), and vibrations corresponding to the C-I and C-Cl bonds in the lower frequency region.

Synthesis Pathway

The primary route to **2-Chloro-3-iodo-5-nitropyridine** involves the direct iodination of the readily available precursor, 2-chloro-5-nitropyridine. This transformation leverages the electron-rich nature of the pyridine ring, which, despite the deactivating nitro group, can undergo electrophilic substitution.

Caption: General workflow for the synthesis of **2-Chloro-3-iodo-5-nitropyridine**.

Detailed Synthetic Protocol

Causality: Sulfuric acid acts as a catalyst, activating the N-Iodosuccinimide (NIS) to generate a potent electrophilic iodine species (I⁺). The reaction proceeds regioselectively at the C3 position, which is the most activated position for electrophilic attack on the 2-chloro-5-nitropyridine scaffold.

- Reaction Setup: To a solution of 2-chloro-5-nitropyridine in concentrated sulfuric acid, add N-Iodosuccinimide (NIS) portion-wise while maintaining the temperature.
- Reaction Execution: Stir the resulting mixture at room temperature for approximately 12 hours, monitoring the reaction progress by TLC or LC-MS.
- Workup: Upon completion, carefully pour the reaction mixture into ice water.
- Extraction: Extract the aqueous mixture with a suitable organic solvent, such as dichloromethane (DCM).
- Washing: Wash the combined organic layers sequentially with water, a saturated aqueous solution of sodium bicarbonate (NaHCO₃), and brine to remove residual acid and salts.[2]

- Purification: Dry the organic phase over anhydrous sodium sulfate, filter, and concentrate under reduced pressure. The crude product is then purified by column chromatography on silica gel to yield the final product.[2]

Reactivity and Strategic Application

The synthetic utility of **2-chloro-3-iodo-5-nitropyridine** stems from the differential reactivity of its two halogen substituents. The carbon-iodine bond is significantly weaker and more polarizable than the carbon-chlorine bond, making it the preferred site for metal-catalyzed cross-coupling reactions. This allows for a predictable and sequential functionalization strategy.

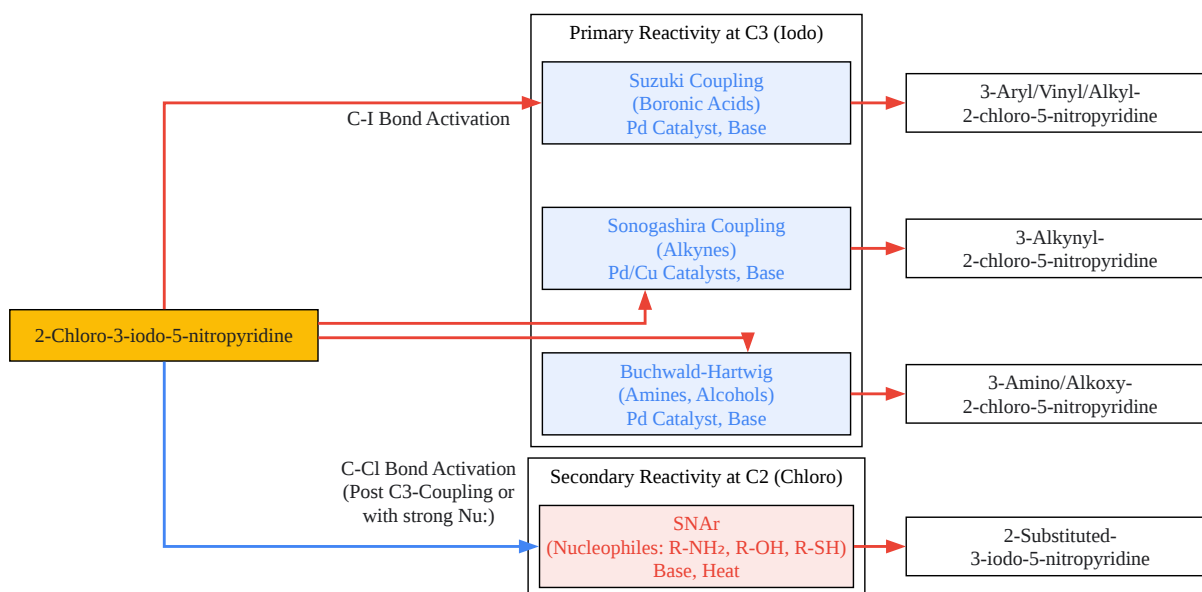

[Click to download full resolution via product page](#)

Caption: Differential reactivity pathways of **2-Chloro-3-iodo-5-nitropyridine**.

Site-Selective Cross-Coupling at the C3-Iodo Position

The C-I bond is the workhorse of this molecule. Its high reactivity in palladium-catalyzed cycles allows for the introduction of a wide array of substituents with high fidelity, leaving the C-Cl bond intact for subsequent transformations.

- Suzuki-Miyaura Coupling: Introduction of aryl or vinyl groups using boronic acids or esters. This is arguably the most common application.
- Sonogashira Coupling: Formation of a C-C triple bond by coupling with terminal alkynes, a key reaction for building rigid molecular scaffolds.
- Buchwald-Hartwig Amination: Creation of C-N bonds by coupling with primary or secondary amines, essential for many pharmaceutical syntheses.

Exemplary Protocol: Suzuki-Miyaura Coupling

Causality: A palladium(0) catalyst, such as Pd(PPh₃)₄ or one generated in situ from Pd(OAc)₂ and a phosphine ligand, undergoes oxidative addition preferentially into the weaker C-I bond. The subsequent steps of transmetalation with the activated boronic acid and reductive elimination form the new C-C bond and regenerate the catalyst. A base is required to activate the boronic acid.

- Inert Atmosphere: To a flame-dried flask under an inert atmosphere (Argon or Nitrogen), add **2-chloro-3-iodo-5-nitropyridine**, the desired boronic acid (1.1-1.5 equivalents), a palladium catalyst (e.g., Pd(PPh₃)₄, 2-5 mol%), and a base (e.g., K₂CO₃ or Cs₂CO₃, 2-3 equivalents).
- Solvent Addition: Add a degassed solvent system, typically a mixture like Dioxane/Water or Toluene/Ethanol/Water.
- Heating: Heat the reaction mixture to 80-100 °C and stir until the starting material is consumed (monitor by TLC/LC-MS).
- Workup and Purification: Cool the reaction to room temperature, dilute with water, and extract with an organic solvent (e.g., Ethyl Acetate). Wash the combined organic layers, dry,

concentrate, and purify by flash chromatography to obtain the 3-aryl-2-chloro-5-nitropyridine product.

Nucleophilic Aromatic Substitution (S_NAr) at the C2-Chloro Position

The C2 position is highly activated towards nucleophilic attack due to the strong electron-withdrawing effects of both the ring nitrogen and the C5-nitro group. While the C-Cl bond is less reactive than C-I in cross-coupling, it is susceptible to S_NAr. This reaction can be performed on the product of a C3-coupling reaction or, with sufficiently strong nucleophiles, directly on the starting material.

- Mechanism: The reaction proceeds via a Meisenheimer complex, a resonance-stabilized anionic intermediate. The stability of this intermediate is enhanced by the nitro group, facilitating the displacement of the chloride ion.[7][8]
- Common Nucleophiles: Amines, alkoxides, and thiolates are effective nucleophiles for this transformation.

Safety and Handling

Proper handling is critical when working with highly functionalized and potentially hazardous reagents.

- Hazard Identification: **2-Chloro-3-iodo-5-nitropyridine** is classified as harmful if swallowed (H302) and causes serious eye damage (H318).[4] The related compound, 2-chloro-5-nitropyridine, is known to cause skin and respiratory irritation.[3][9]
- Personal Protective Equipment (PPE): Always wear appropriate PPE, including a lab coat, nitrile gloves, and chemical safety goggles.[5]
- Handling Precautions:
 - Handle in a well-ventilated fume hood to avoid inhalation of dust.[9]
 - Avoid contact with skin and eyes.[10]

- Wash hands thoroughly after handling.[5]
- Keep away from strong oxidizing agents, strong acids, and strong bases.[5]
- Storage: Store in a tightly sealed container in a cool, dry, and well-ventilated area, preferably under an inert atmosphere as recommended.[2][10]
- Disposal: Dispose of contents and container in accordance with local, regional, and national regulations.

Conclusion

2-Chloro-3-iodo-5-nitropyridine is a sophisticated chemical tool that offers a reliable platform for sequential, site-selective functionalization. Its predictable reactivity, governed by the interplay between its halogen and nitro substituents, provides a clear strategic advantage in multi-step syntheses. By understanding its fundamental properties and applying the robust protocols outlined in this guide, researchers can effectively leverage this versatile building block to accelerate the discovery and development of novel molecules.

References

- Jubilant Ingrevia Limited. (n.d.). 2-Chloro-5-nitropyridine Safety Data Sheet.
- Xinfu Pharmaceutical Co Ltd. (2020). Preparation method of high-yield 2-chloro-5-nitropyridine. Google Patents (CN109456257B).
- IndiaMART. (n.d.). 2 Chloro 5 Iodo 3 Nitropyridine Chemical Powder, 98%.
- ResearchGate. (n.d.). 2-Chloro-5-nitropyridine. Retrieved from [\[Link\]](#)
- RUIDENG. (n.d.). What is the synthesis and application of 2-Chloro-3-nitropyridine in organic chemistry? Retrieved from [\[Link\]](#)
- Ng, S. W. (2010). 2-Chloro-5-nitropyridine. Acta Crystallographica Section E: Structure Reports Online, 66(Pt 4), o848. Retrieved from [\[Link\]](#)
- Google Patents. (2011). Method for preparing 2-chloro-5-nitropyridine. (CN102040554A).
- PubChem. (n.d.). 2-Chloro-5-nitropyridine. National Center for Biotechnology Information. Retrieved from [\[Link\]](#)

- Georganics. (n.d.). 2-Chloro-5-iodo-3-nitropyridine. Retrieved from [[Link](#)]
- SpectraBase. (n.d.). 2-CHLORO-3-FLUORO-5-IODO-4-METHYLPYRIDINE. Retrieved from [[Link](#)]

Need Custom Synthesis?

BenchChem offers custom synthesis for rare earth carbides and specific isotopic labeling.

Email: info@benchchem.com or [Request Quote Online](#).

Sources

- 1. indiamart.com [indiamart.com]
- 2. 2-Chloro-3-iodo-5-nitropyridine | 25391-60-0 [chemicalbook.com]
- 3. 2-Chloro-5-nitropyridine | C5H3ClN2O2 | CID 78308 - PubChem [pubchem.ncbi.nlm.nih.gov]
- 4. sigmaaldrich.com [sigmaaldrich.com]
- 5. jubilantingrevia.com [jubilantingrevia.com]
- 6. pdf.benchchem.com [pdf.benchchem.com]
- 7. researchgate.net [researchgate.net]
- 8. 2-Chloro-5-nitropyridine - PMC [pmc.ncbi.nlm.nih.gov]
- 9. fishersci.com [fishersci.com]
- 10. 2-Amino-5-chloro-3-nitropyridine - Safety Data Sheet [chemicalbook.com]
- To cite this document: BenchChem. [An In-Depth Technical Guide to 2-Chloro-3-iodo-5-nitropyridine]. BenchChem, [2026]. [Online PDF]. Available at: [<https://www.benchchem.com/product/b1589499#2-chloro-3-iodo-5-nitropyridine-chemical-properties>]

Disclaimer & Data Validity:

The information provided in this document is for Research Use Only (RUO) and is strictly not intended for diagnostic or therapeutic procedures. While BenchChem strives to provide

accurate protocols, we make no warranties, express or implied, regarding the fitness of this product for every specific experimental setup.

Technical Support: The protocols provided are for reference purposes. Unsure if this reagent suits your experiment? [[Contact our Ph.D. Support Team for a compatibility check](#)]

Need Industrial/Bulk Grade? [Request Custom Synthesis Quote](#)

BenchChem

Our mission is to be the trusted global source of essential and advanced chemicals, empowering scientists and researchers to drive progress in science and industry.

Contact

Address: 3281 E Guasti Rd

Ontario, CA 91761, United States

Phone: (601) 213-4426

Email: info@benchchem.com