

"2-Chloro-6-(trifluoromethyl)isonicotinic acid" potential research applications

Author: BenchChem Technical Support Team. **Date:** May 2026

Compound of Interest

Compound Name: 2-Chloro-6-(trifluoromethyl)isonicotinic acid

CAS No.: 796090-23-8

Cat. No.: B1589544

[Get Quote](#)

Technical Whitepaper: 2-Chloro-6-(trifluoromethyl)isonicotinic Acid Strategic Utilization in Medicinal & Agrochemical Discovery

Executive Summary

2-Chloro-6-(trifluoromethyl)isonicotinic acid (CAS: 796090-23-8) represents a "privileged structure" in organic synthesis. It combines the orthogonal reactivity of a halogenated pyridine with the metabolic stability and lipophilicity of a trifluoromethyl group.^[1] This scaffold is increasingly utilized to develop auxin-mimic herbicides, systemic acquired resistance (SAR) inducers in plants, and kinase inhibitors in oncology.^[1] Its unique substitution pattern allows for precise, regioselective functionalization, making it an ideal core for Fragment-Based Drug Discovery (FBDD).^[1]

Chemical Profile & Physicochemical Properties[1][2][3][4][5][6]

Property	Data
IUPAC Name	2-Chloro-6-(trifluoromethyl)pyridine-4-carboxylic acid
CAS Number	796090-23-8
Molecular Formula	C ₇ H ₃ ClF ₃ NO ₂
Molecular Weight	225.55 g/mol
Appearance	White to off-white crystalline solid
Acidity (pKa)	~2.57 (Predicted) - Highly acidic due to electron-withdrawing CF ₃ & Cl
Lipophilicity (LogP)	~2.33 - Enhanced membrane permeability vs. non-fluorinated analogs
H-Bond Donors/Acceptors	1 Donor / 3 Acceptors

Structural Analysis:

- Position 2 (Cl): Activated for nucleophilic aromatic substitution (S_NAr) and transition-metal catalyzed cross-coupling (e.g., Suzuki-Miyaura) due to the electron-deficient nature of the pyridine ring.
- Position 4 (COOH): A versatile handle for amidation, esterification, or reduction.[1] The "isonicotinic" position is historically significant for anti-tubercular activity (e.g., Isoniazid).[1][2]
- Position 6 (CF₃): Provides metabolic blocking (preventing oxidation) and increases lipophilicity, often improving the bioavailability of the final drug candidate.[1]

Core Research Applications

A. Agrochemicals: Auxin Mimics & Resistance Inducers

The structural homology of this compound to Picloram and Clopyralid (commercial pyridine herbicides) suggests potent auxin-mimic activity.[1]

- Mechanism: These compounds bind to the TIR1 ubiquitin ligase complex, disrupting auxin homeostasis and causing uncontrolled growth in broadleaf weeds.[1]
- Plant Immunity: Analogs of 2,6-dichloroisonicotinic acid (INA) are known to induce Systemic Acquired Resistance (SAR) in crops, priming them against viral and fungal pathogens.[1][3] The 6-CF₃ group acts as a bioisostere for chlorine, potentially altering transport kinetics in plant tissues.[1]

B. Medicinal Chemistry: Kinase Inhibitors & Anti-Infectives[1]

- Kinase Inhibition: The pyridine core is a common motif in Type II kinase inhibitors (e.g., Sorafenib analogs).[1] The 2-chloro group allows for the attachment of a "hinge-binding" motif or a hydrophobic tail via Suzuki coupling, while the carboxylic acid can be converted to an amide linker.[1]
- Anti-Tubercular Agents: As a derivative of isonicotinic acid, this scaffold is screened for activity against Mycobacterium tuberculosis.[1][2] The CF₃ group can block the acetylation deactivation pathway common to isoniazid resistance.[1]

Experimental Workflows & Protocols

Diagram: Reactivity & Diversification Map

The following diagram illustrates the orthogonal functionalization pathways available for this scaffold.

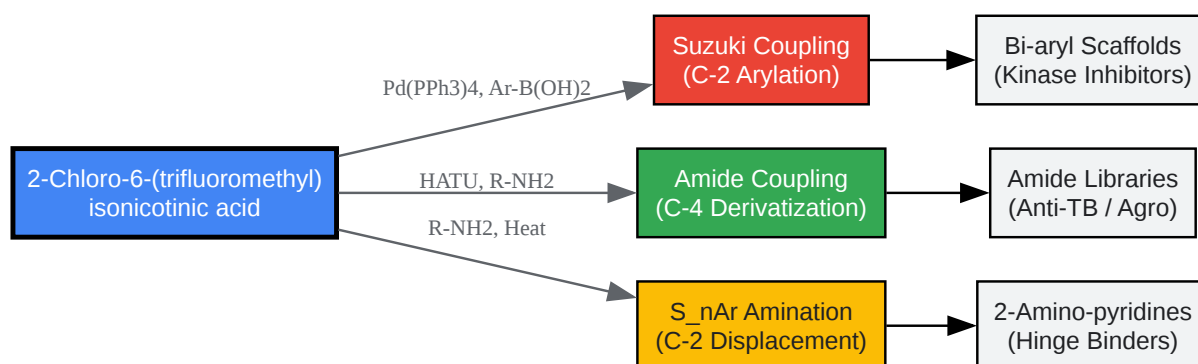

[Click to download full resolution via product page](#)

Caption: Orthogonal reactivity map showing C-2 cross-coupling and C-4 amidation pathways.

Protocol 1: C-2 Selective Suzuki-Miyaura Coupling

Objective: To introduce an aryl group at the 2-position while preserving the carboxylic acid.

Reagents:

- Substrate: **2-Chloro-6-(trifluoromethyl)isonicotinic acid** (1.0 equiv)
- Boronic Acid: Aryl-B(OH)₂ (1.2 equiv)
- Catalyst: Pd(dppf)Cl₂[1][4]·DCM (0.05 equiv)[1]
- Base: K₂CO₃ (3.0 equiv)[1]
- Solvent: 1,4-Dioxane/Water (4:1)

Step-by-Step:

- Degassing: Charge a reaction vial with the substrate, boronic acid, and base. Purge with nitrogen for 5 minutes.[1]
- Catalyst Addition: Add Pd(dppf)Cl₂[1]·DCM under a nitrogen stream.[1]
- Solvation: Add degassed solvent mixture. Seal the vial.
- Reaction: Heat to 90°C for 4–12 hours. Monitor by LC-MS (Target mass = MW of Substrate + MW of Aryl - HCl).
- Workup: Acidify to pH 3 with 1N HCl (critical to recover the carboxylic acid product). Extract with Ethyl Acetate.[1]
- Purification: The crude product is often pure enough for the next step; otherwise, purify via reverse-phase HPLC.[1]

Protocol 2: C-4 Amide Library Generation

Objective: To synthesize a library of amides for biological screening.

Reagents:

- Coupling Agent: HATU (1.2 equiv)[1]
- Base: DIPEA (3.0 equiv)[1]
- Amine: R-NH₂ (1.1 equiv)
- Solvent: DMF (Anhydrous)[1]

Step-by-Step:

- Activation: Dissolve the acid substrate in DMF. Add DIPEA and HATU. Stir at room temperature for 15 minutes to form the activated ester.
- Coupling: Add the amine (R-NH₂).[1]
- Reaction: Stir at room temperature for 2–4 hours.
- Quench: Add water. If the product precipitates, filter and wash.[1] If not, extract with DCM.[1]
- Note: For electron-deficient amines (e.g., anilines), heating to 50°C may be required.[1]

Safety & Handling

- Hazard Classification: Irritant (H315, H319, H335).[1] Toxic if swallowed (H301) is possible for pyridine derivatives.[1]
- Handling: Use in a fume hood.[1] The CF₃ group ensures high volatility is unlikely, but dust inhalation should be avoided.[1]
- Waste: Halogenated organic waste.[1] Do not mix with strong oxidizers.[1]

References

- PubChem. "2-Chloro-6-(trifluoromethyl)nicotinic acid | C₇H₃ClF₃NO₂." National Institutes of Health (NIH).[1] [Link](#)[1]
- ChemScene. "**2-Chloro-6-(trifluoromethyl)isonicotinic acid** Product Data." ChemScene. [Link](#)

- Invasive.org. "Picloram: Herbicide Basics and Mode of Action." [1] Center for Invasive Species and Ecosystem Health. [1] [Link](#)
- BenchChem. "Biological Activities of Isonicotinic Acid Derivatives." BenchChem Technical Notes. [Link](#) [1]
- ResearchGate. "Synthesis and Suzuki Cross-Coupling Reactions of 2,6-Bis(trifluoromethyl)pyridine-4-boronic Acid." ResearchGate. [1][5] [Link](#)
- Google Patents. "Synthesis method of 2-chloro-4-(trifluoromethyl) pyridine." CN116425671A. [1] [Link](#)

Need Custom Synthesis?

BenchChem offers custom synthesis for rare earth carbides and specific isotopic labeling.

Email: info@benchchem.com or [Request Quote Online](#).

Sources

- 1. Picloram - Wikipedia [en.wikipedia.org]
- 2. pdf.benchchem.com [pdf.benchchem.com]
- 3. researchgate.net [researchgate.net]
- 4. Yoneda Labs [yonedalabs.com]
- 5. researchgate.net [researchgate.net]
- To cite this document: BenchChem. ["2-Chloro-6-(trifluoromethyl)isonicotinic acid" potential research applications]. BenchChem, [2026]. [Online PDF]. Available at: [<https://www.benchchem.com/product/b1589544/docs#2-chloro-6-trifluoromethyl-isonicotinic-acid-potential-research-applications>]

Disclaimer & Data Validity:

The information provided in this document is for Research Use Only (RUO) and is strictly not intended for diagnostic or therapeutic procedures. While BenchChem strives to provide

accurate protocols, we make no warranties, express or implied, regarding the fitness of this product for every specific experimental setup.

Technical Support: The protocols provided are for reference purposes. Unsure if this reagent suits your experiment?

Need Industrial/Bulk Grade? [Request Custom Synthesis Quote](#)

BenchChem

Our mission is to be the trusted global source of essential and advanced chemicals, empowering scientists and researchers to drive progress in science and industry.

Contact

Address: 3281 E Guasti Rd

Ontario, CA 91761, United States

Phone: (601) 213-4426

Email: info@benchchem.com

[Contact our Ph.D. Support Team for a compatibility check](#)