

Technical Support Center: Optimizing 2-(Chloromethyl)phenylacetic Acid Synthesis

Author: BenchChem Technical Support Team. **Date:** May 2026

Compound of Interest

Compound Name: 2-(Chloromethyl)phenylacetic acid

CAS No.: 95335-46-9

Cat. No.: B1588471

[Get Quote](#)

This guide is designed for researchers, chemists, and drug development professionals to troubleshoot and optimize the synthesis of **2-(Chloromethyl)phenylacetic acid**. Our focus is on providing actionable, evidence-based solutions to common issues, particularly extended reaction times, by explaining the causality behind experimental choices.

Introduction: The Challenge of Sluggish Reactions

2-(Chloromethyl)phenylacetic acid is a valuable building block in the synthesis of various pharmaceuticals and agrochemicals. However, its preparation, typically via chloromethylation of a phenylacetic precursor, is often plagued by slow reaction kinetics, leading to decreased throughput and the formation of undesirable byproducts. This guide provides a deep dive into the factors governing the reaction rate and offers systematic approaches to accelerate the synthesis while maintaining high yield and purity.

Frequently Asked Questions (FAQs) & Troubleshooting

Q1: My chloromethylation reaction is incredibly slow or has completely stalled. What are the primary factors I should investigate?

A1: A stalled or slow reaction is one of the most common hurdles. The rate of this electrophilic aromatic substitution is governed by several interdependent factors. Here's a breakdown of the most critical parameters:

- **Catalyst Choice and Activity:** The reaction is almost always catalyzed by a Lewis acid. The catalyst's role is to activate the chloromethylating agent (typically formaldehyde or its polymer, paraformaldehyde) to generate a potent electrophile, the chloromethyl cation or a related complex. The activity of Lewis acids varies significantly. Stronger Lewis acids like Aluminum Chloride (AlCl_3) or Iron(III) Chloride (FeCl_3) can accelerate the reaction but may also promote side reactions if not carefully controlled. Milder catalysts like Zinc Chloride (ZnCl_2) are common but may require higher temperatures or longer reaction times.^{[1][2]} Indium(III) Chloride has also been shown to be an effective catalyst.^[3] The choice of catalyst is paramount and should be tailored to the reactivity of your specific substrate.
- **Reaction Temperature:** Temperature has a direct and significant impact on the reaction rate. However, there is a critical trade-off. While higher temperatures increase kinetics, they also accelerate the formation of side products, such as diarylmethanes and polymers (tar).^[4] Optimal temperatures are typically in the range of 30°C to 70°C.^[3] Exceeding 100°C can lead to significantly reduced yields of the desired product.^[3]
- **Reagents and Anhydrous Conditions:** The most common chloromethylating agents are a combination of formaldehyde (or paraformaldehyde) and hydrogen chloride (HCl).^[1] The reaction is highly sensitive to moisture. Water can deactivate the Lewis acid catalyst and hydrolyze the product. Therefore, using anhydrous reagents and solvents is crucial for optimal performance.^[5] The rate of introduction of gaseous HCl can also be a rate-limiting step; ensuring a steady and sufficient supply is essential.^[3]
- **Solvent System:** The solvent must be inert to the reaction conditions and capable of dissolving the starting materials. Common choices include halogenated hydrocarbons like chlorobenzene or 1,2-dichloroethane, as well as toluene.^[3] The solvent choice can influence

the reaction temperature (via its boiling point) and the solubility of the HCl gas, thereby affecting the overall reaction rate.

Q2: Besides the slow rate, my yield is poor. What are the most common side reactions and how can I minimize them?

A2: Poor yields are typically a result of competing side reactions that consume starting material or the desired product. The primary culprits are:

- **Diarylmethane Formation:** This is a very common byproduct where the newly formed, electron-rich **2-(chloromethyl)phenylacetic acid** undergoes a second electrophilic substitution with another molecule of the starting material.^[1] This is a type of Friedel-Crafts alkylation. To minimize this, avoid high concentrations of the starting material and consider adding the aromatic substrate slowly to the reaction mixture.
- **Dichloromethylation:** The aromatic ring can react a second time with the chloromethylating agent, leading to the formation of 2-(dichloromethyl)phenylacetic acid.^[6] This is more likely to occur with highly active catalysts or at elevated temperatures.
- **α -Chlorination:** The alpha-carbon of the acetic acid side chain can also be chlorinated, yielding 2-(chloromethyl)- α -chlorophenylacetic acid.^[6] While different from the primary chloromethylation mechanism, this pathway can be promoted under certain conditions.
- **Polymerization/Tar Formation:** Under harsh conditions (e.g., excessively high temperatures or catalyst concentrations), polymerization of formaldehyde or the aromatic substrate can lead to the formation of intractable tars, significantly complicating purification and reducing yield.^[4]

Q3: How do I select the best catalyst to accelerate my reaction without compromising the yield?

A3: Catalyst selection is a balancing act between reactivity and selectivity. A catalyst that is too aggressive will favor side reactions. Based on patent literature, a comparative analysis can guide your choice.

Catalyst	Solvent	Temperature (°C)	Reaction Time (h)	Yield of Value Product	Reference
Iron(III) Chloride (FeCl ₃)	Chlorobenzene	50	2	75%	[3]
Indium(III) Chloride (InCl ₃)	Toluene	40	4	80%	[3]
Aluminum Chloride (AlCl ₃)	Toluene	100	2	30%	[3]
Tin(IV) Chloride (SnCl ₄)	1,2-Dichloroethane	85	4	30%	[3]

Analysis: From this data, Indium(III) Chloride and Iron(III) Chloride appear to be the most effective catalysts, providing high yields at moderate temperatures and reasonable reaction times.[3] In contrast, Aluminum Chloride and Tin(IV) Chloride required much higher temperatures and still resulted in significantly lower yields, suggesting they may be too reactive and promote side product formation under these conditions.[3]

Visualizing the Process

Reaction Mechanism

The synthesis proceeds via a classic electrophilic aromatic substitution. The Lewis acid catalyst is essential for activating formaldehyde to form the reactive electrophile that attacks the phenylacetic acid ring.

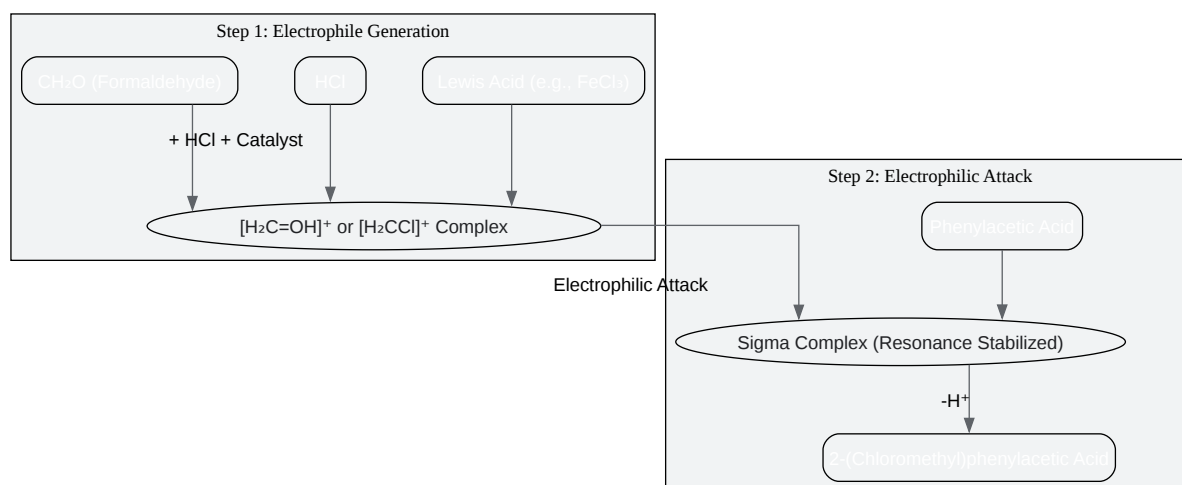

[Click to download full resolution via product page](#)

Caption: Mechanism of Lewis acid-catalyzed chloromethylation.

Troubleshooting Workflow

If you encounter a slow reaction, follow this logical workflow to diagnose and resolve the issue.

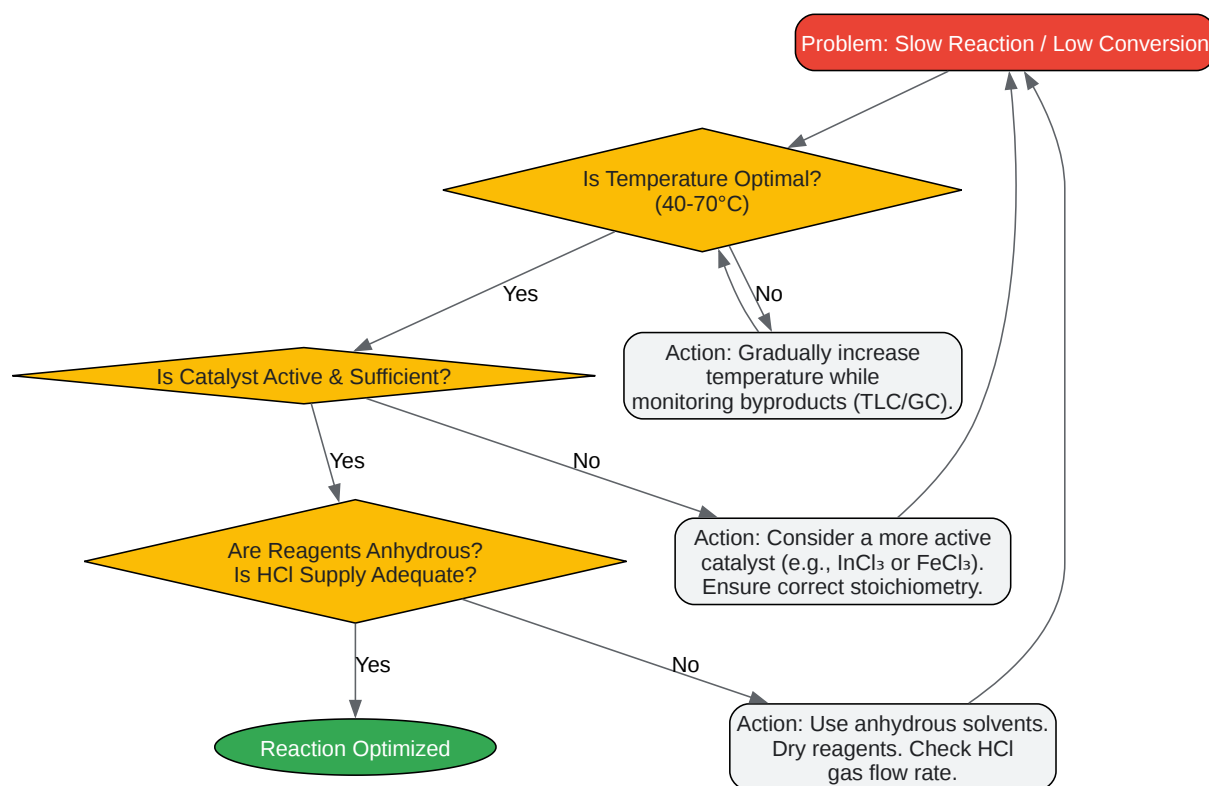

[Click to download full resolution via product page](#)

Caption: A systematic workflow for troubleshooting slow reactions.

Optimized Experimental Protocol

This protocol is based on a method demonstrated to provide a high yield in a relatively short time, utilizing Indium(III) Chloride as the catalyst.[3]

Disclaimer: This procedure involves hazardous materials, including gaseous hydrogen chloride and potentially carcinogenic byproducts like bis(chloromethyl) ether.[5] All operations must be performed in a certified chemical fume hood with appropriate personal protective equipment (PPE).

Materials & Equipment:

- Reactants: Phenylacetic acid, Indium(III) Chloride (anhydrous), Paraformaldehyde, Toluene (anhydrous), Hydrogen Chloride (gas).
- Equipment: Three-necked round-bottom flask, magnetic stirrer with heating mantle, reflux condenser, gas inlet tube, thermometer, and a gas scrubber (e.g., containing NaOH solution) for the HCl off-gas.

Procedure:

- Setup: Assemble the glassware and ensure the system is dry and under an inert atmosphere (e.g., Nitrogen).
- Charging the Flask: To the flask, add phenylacetic acid (1.0 eq) and anhydrous toluene.
- Catalyst and Reagent Addition: Add Indium(III) Chloride (0.1 eq) and paraformaldehyde (3.0 eq) to the stirred solution.
- Reaction Initiation: Begin bubbling dry hydrogen chloride gas through the mixture while gradually heating the reaction to 40°C.
- Reaction Monitoring: Maintain the temperature at 40°C and continue stirring. Monitor the reaction's progress by taking small aliquots and analyzing them via TLC or HPLC. The reaction is typically complete within 4-5 hours.[3]
- Work-up:
 - Once the reaction is complete, cool the mixture to room temperature.
 - Carefully add a small amount of methanol to quench any reactive species.

- Transfer the mixture to a separatory funnel and wash sequentially with dilute HCl and then a saturated sodium bicarbonate solution to remove the catalyst and unreacted acid.
- Wash the organic phase with brine, dry it over anhydrous magnesium sulfate, and filter.
- Purification: Remove the solvent (toluene) under reduced pressure. The resulting crude product can be further purified by recrystallization or column chromatography to yield pure **2-(Chloromethyl)phenylacetic acid**.

References

- Method for producing 2-chloromethylphenyl acetic acid derivatives - Google Patents.
- New studies in aromatic chloromethylation - Durham E-Theses.
- troubleshooting low conversion rates in 2-chlorothiophene chloromethylation - Benchchem.
- Blanc Chloromethylation - J&K Scientific LLC.
- PROCESS FOR PRODUCING CHLOROMETHYLPHENYLACETIC ACID - European Patent Office - EP 1072580 B1 - EPO.
- CN101774880A - Method for catalytic reaction of chloromethylation of aromatic cyclic compound - Google Patents.
- 2-Chlorophenylacetic acid synthesis - ChemicalBook.
- An inexpensive and convenient procedure for chloromethylation of aromatic hydrocarbons by phase transfer catalysis in aqueous media - ResearchGate.
- US2541408A - Catalytic chloromethylation of aromatic compounds - Google Patents.
- Blanc Chloromethylation - Removing BCME from Product - Sciencemadness.org.

Need Custom Synthesis?

BenchChem offers custom synthesis for rare earth carbides and specific isotopic labeling.

Email: info@benchchem.com or [Request Quote Online](#).

Sources

- [1. etheses.dur.ac.uk \[etheses.dur.ac.uk\]](https://etheses.dur.ac.uk)
- [2. CN101774880A - Method for catalytic reaction of chloromethylation of aromatic cyclic compound - Google Patents \[patents.google.com\]](#)
- [3. WO2003072538A1 - Method for producing 2-chloromethylphenyl acetic acid derivatives - Google Patents \[patents.google.com\]](#)
- [4. pdf.benchchem.com \[pdf.benchchem.com\]](https://pdf.benchchem.com)
- [5. jk-sci.com \[jk-sci.com\]](https://jk-sci.com)
- [6. data.epo.org \[data.epo.org\]](https://data.epo.org)
- To cite this document: BenchChem. [Technical Support Center: Optimizing 2-(Chloromethyl)phenylacetic Acid Synthesis]. BenchChem, [2026]. [Online PDF]. Available at: [\[https://www.benchchem.com/product/b1588471/docs#technical-support-center-optimizing-2-chloromethyl-phenylacetic-acid-synthesis\]](https://www.benchchem.com/product/b1588471/docs#technical-support-center-optimizing-2-chloromethyl-phenylacetic-acid-synthesis)

Disclaimer & Data Validity:

The information provided in this document is for Research Use Only (RUO) and is strictly not intended for diagnostic or therapeutic procedures. While BenchChem strives to provide accurate protocols, we make no warranties, express or implied, regarding the fitness of this product for every specific experimental setup.

Technical Support: The protocols provided are for reference purposes. Unsure if this reagent suits your experiment?

Need Industrial/Bulk Grade? [Request Custom Synthesis Quote](#)

BenchChem

Our mission is to be the trusted global source of essential and advanced chemicals, empowering scientists and researchers to drive progress in science and industry.

Contact

Address: 3281 E Guasti Rd
Ontario, CA 91761, United States
Phone: (601) 213-4426
Email: info@benchchem.com

Contact our Ph.D. Support Team for a compatibility check