

# Application Notes & Protocols: A Detailed Guide to Alcohol Protection Using Isopropyldimethylchlorosilane

**Author:** BenchChem Technical Support Team. **Date:** May 2026

## Compound of Interest

Compound Name: *Isopropyldimethylchlorosilane*

CAS No.: 3634-56-8

Cat. No.: B1588863

[Get Quote](#)

## Abstract

In the intricate landscape of multi-step organic synthesis, the strategic protection and deprotection of functional groups is paramount to achieving desired molecular architectures.[1] [2] Silyl ethers stand out as one of the most versatile and widely employed protecting groups for alcohols, owing to their ease of formation, tunable stability, and mild removal conditions.[1] [3] This document provides an in-depth technical guide on the use of **Isopropyldimethylchlorosilane** (IPDMSCI) for the protection of hydroxyl moieties. The isopropyldimethylsilyl (IPDMS) ether offers a unique balance of steric bulk and reactivity, positioning it as a valuable tool for researchers, scientists, and drug development professionals. We will explore the underlying mechanisms, provide detailed experimental protocols, and discuss its application in orthogonal synthetic strategies.

## Introduction: The Role of Silyl Ethers in Modern Synthesis

The hydroxyl group is ubiquitous in organic chemistry, yet its acidic proton and nucleophilic oxygen can interfere with a wide array of transformations, such as those involving organometallics, strong bases, or hydrides.[4][5] Protecting groups serve as temporary masks, rendering the alcohol inert to specific reaction conditions.[6] Silyl ethers, formed by reacting an alcohol with a silyl halide, are a cornerstone of this strategy.[1][4]

The stability of a silyl ether is primarily governed by the steric hindrance around the silicon atom.[7][8] This allows chemists to select from a panel of silylating agents to match the demands of their synthetic route. The Isopropyldimethylsilyl (IPDMS) group occupies a strategic intermediate position in terms of stability, generally considered more robust than a Trimethylsilyl (TMS) ether but more labile than a tert-Butyldimethylsilyl (TBS) or Triisopropylsilyl (TIPS) ether. This characteristic makes IPDMSCl an excellent reagent for syntheses requiring fine-tuning of protecting group stability and selective deprotection.[9][10]

## Mechanism of Silylation

The formation of an isopropyldimethylsilyl ether proceeds via a nucleophilic substitution at the silicon center of **Isopropyldimethylchlorosilane**. The reaction is typically facilitated by a nitrogenous base, such as imidazole or triethylamine, in an aprotic solvent.[9][11]

The mechanism can be described in two key steps:

- **Activation of the Alcohol:** The base deprotonates the alcohol to form a more nucleophilic alkoxide.
- **Nucleophilic Attack:** The alkoxide attacks the electrophilic silicon atom of IPDMSCl, displacing the chloride ion in an SN2-like fashion.[12][13] The base also serves to neutralize the hydrochloric acid generated during the reaction.[9]

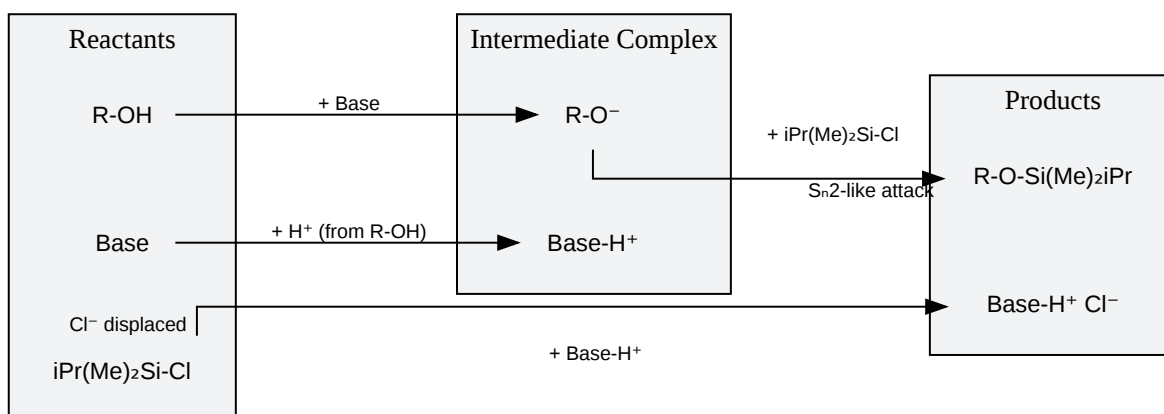

[Click to download full resolution via product page](#)

Caption: General mechanism for alcohol protection with IPDMSCl.

## Experimental Protocol: Protection of a Primary Alcohol

This protocol provides a reliable method for the silylation of a primary alcohol using **Isopropyl dimethylchlorosilane**. The procedure should be conducted under an inert atmosphere (e.g., nitrogen or argon) to prevent hydrolysis of the silyl chloride.

### Materials

- Alcohol (1.0 eq.)
- **Isopropyl dimethylchlorosilane** (1.2 - 1.5 eq.)
- Imidazole (2.0 - 2.5 eq.)
- Anhydrous N,N-Dimethylformamide (DMF) or Dichloromethane (DCM)
- Saturated aqueous sodium bicarbonate (NaHCO<sub>3</sub>) solution
- Brine (saturated aqueous NaCl solution)

- Anhydrous magnesium sulfate ( $\text{MgSO}_4$ ) or sodium sulfate ( $\text{Na}_2\text{SO}_4$ )
- Standard laboratory glassware, magnetic stirrer, and inert atmosphere setup.

## Step-by-Step Procedure

- Preparation: To a dry, round-bottom flask under an inert atmosphere, add the alcohol (1.0 eq.) and imidazole (2.0 - 2.5 eq.).
- Dissolution: Add anhydrous DMF (or DCM) to dissolve the solids, typically to a concentration of 0.5 M with respect to the alcohol. Stir the solution at room temperature.
- Addition of Silylating Agent: Slowly add **Isopropyldimethylchlorosilane** (1.2 - 1.5 eq.) to the stirring solution at 0 °C (ice bath). Causality Note: The use of imidazole is crucial as it reacts with the silyl chloride to form a highly reactive silylimidazolium intermediate, accelerating the reaction, and also neutralizes the generated HCl.<sup>[11][12]</sup> Adding the chlorosilane slowly at a reduced temperature helps to control any potential exotherm.
- Reaction Monitoring: Allow the reaction to warm to room temperature and stir for 1-4 hours. Monitor the reaction progress by Thin Layer Chromatography (TLC) until the starting alcohol is consumed.
- Workup - Quenching: Once the reaction is complete, cool the flask in an ice bath and slowly add saturated aqueous  $\text{NaHCO}_3$  solution to quench any remaining silyl chloride.
- Extraction: Transfer the mixture to a separatory funnel. If DMF was used, add water and a suitable organic solvent like ethyl acetate or diethyl ether. Extract the aqueous layer two more times with the organic solvent. If DCM was used, add water and separate the layers.
- Washing: Combine the organic extracts and wash sequentially with water and then brine. Causality Note: The water wash removes residual DMF and imidazole salts, while the brine wash helps to break any emulsions and begins the drying process.
- Drying and Concentration: Dry the organic layer over anhydrous  $\text{MgSO}_4$  or  $\text{Na}_2\text{SO}_4$ , filter, and concentrate the solvent under reduced pressure using a rotary evaporator.

- Purification: The crude product can be purified by flash column chromatography on silica gel, typically using a gradient of ethyl acetate in hexanes.

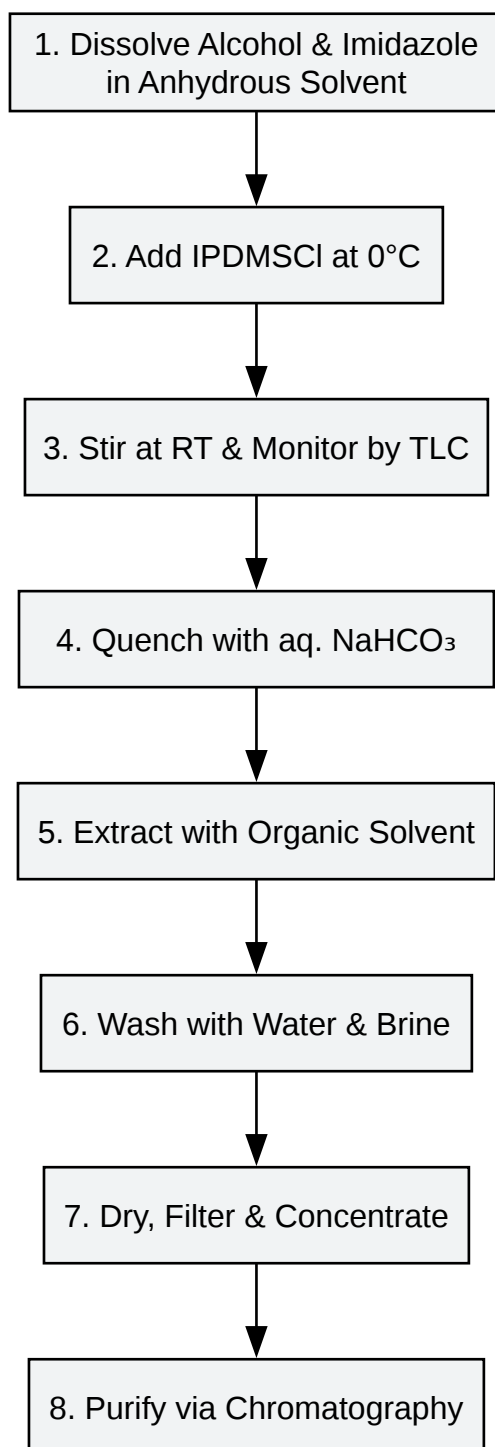

[Click to download full resolution via product page](#)

Caption: Experimental workflow for IPDMS protection of an alcohol.

## Substrate Scope and Reactivity Considerations

The rate of silylation is highly dependent on the steric environment of the hydroxyl group.<sup>[7]</sup> IPDMSCl reacts readily with primary alcohols but will react more slowly with secondary and tertiary alcohols. For sterically hindered substrates, extended reaction times, elevated temperatures, or the use of a more reactive silylating agent like isopropyltrimethylsilyl triflate may be necessary.<sup>[11]</sup>

Substrate Type	Typical Conditions	Approx. Time	Expected Yield	Notes
Primary Alcohol	Imidazole, DMF, RT	1-4 h	>90%	Reaction is generally fast and high-yielding.
Secondary Alcohol	Imidazole, DMF, RT to 40°C	4-12 h	70-90%	May require gentle heating to drive to completion.
Tertiary Alcohol	AgOTf, 2,6-lutidine, DCM	12-24 h	40-70%	Standard conditions are often ineffective; requires conversion to a more reactive silyl triflate in situ. <sup>[14][15]</sup>
Phenol	Imidazole, DMF, RT	1-3 h	>95%	Generally very reactive due to the acidity of the phenolic proton.

This table presents representative data based on established principles of silylation reactions.

## Deprotection of the IPDMS Group

A key advantage of silyl ethers is their selective and mild removal.[10] The IPDMS group can be cleaved under two main conditions: fluoride-mediated cleavage or acidic hydrolysis.

## Fluoride-Mediated Deprotection

This is the most common and mildest method for silyl ether cleavage. The high affinity of silicon for fluoride (the Si-F bond is one of the strongest single bonds) is the driving force for the reaction.[4][16] Tetrabutylammonium fluoride (TBAF) is the most frequently used reagent.

Mechanism of Fluoride-Mediated Cleavage: The fluoride ion attacks the silicon atom, forming a pentacoordinate intermediate which then fragments to release the alkoxide and the fluorosilane.

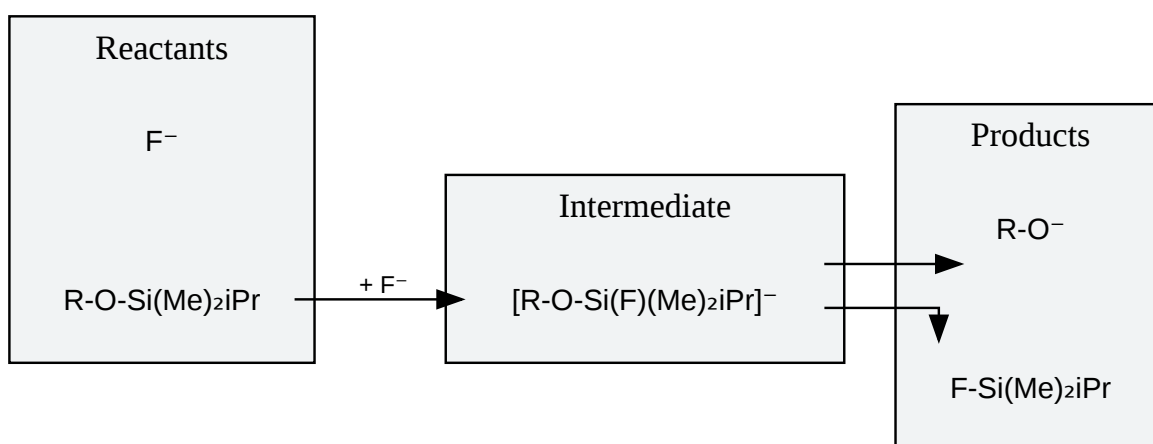

[Click to download full resolution via product page](#)

Caption: Mechanism of fluoride-mediated deprotection of a silyl ether.

## Experimental Protocol: Deprotection using TBAF

- Preparation: Dissolve the IPDMS-protected alcohol (1.0 eq.) in anhydrous tetrahydrofuran (THF) in a flask.
- Reagent Addition: Add a 1.0 M solution of TBAF in THF (1.1 - 1.5 eq.) dropwise to the stirring solution at room temperature.

- **Reaction Monitoring:** Monitor the reaction by TLC. Deprotection is usually complete within 30 minutes to 2 hours.
- **Workup:** Quench the reaction by adding water. Extract the product with ethyl acetate or diethyl ether.
- **Washing and Drying:** Wash the combined organic layers with brine, dry over anhydrous  $\text{Na}_2\text{SO}_4$ , filter, and concentrate under reduced pressure.
- **Purification:** Purify the resulting alcohol by flash column chromatography.

## Acidic Hydrolysis

IPDMS ethers can also be cleaved under acidic conditions, though this method is less common due to the potential for incompatibility with other acid-sensitive functional groups.<sup>[17]</sup> The stability of silyl ethers to acid is highly dependent on steric bulk. The IPDMS group is more acid-labile than TBS or TBDPS groups.<sup>[8]</sup> Typical reagents include acetic acid in THF/water or catalytic amounts of stronger acids like HCl or camphorsulfonic acid (CSA) in methanol.<sup>[11]</sup>

## Orthogonal Protection Strategies

The intermediate stability of the IPDMS group makes it a valuable component in orthogonal protection strategies, where one protecting group can be removed selectively in the presence of others.<sup>[9]</sup>

- **Selective IPDMS Cleavage:** An IPDMS ether can be cleaved with a fluoride source like TBAF under conditions that would leave a more robust silyl ether, such as a tert-Butyldiphenylsilyl (TBDPS) group, intact.<sup>[18]</sup>
- **Selective Cleavage of Other Groups:** A more labile group, like TMS, can be removed with mild acidic or solvolytic conditions (e.g.,  $\text{K}_2\text{CO}_3$  in methanol) while leaving the IPDMS ether untouched.<sup>[10]</sup>

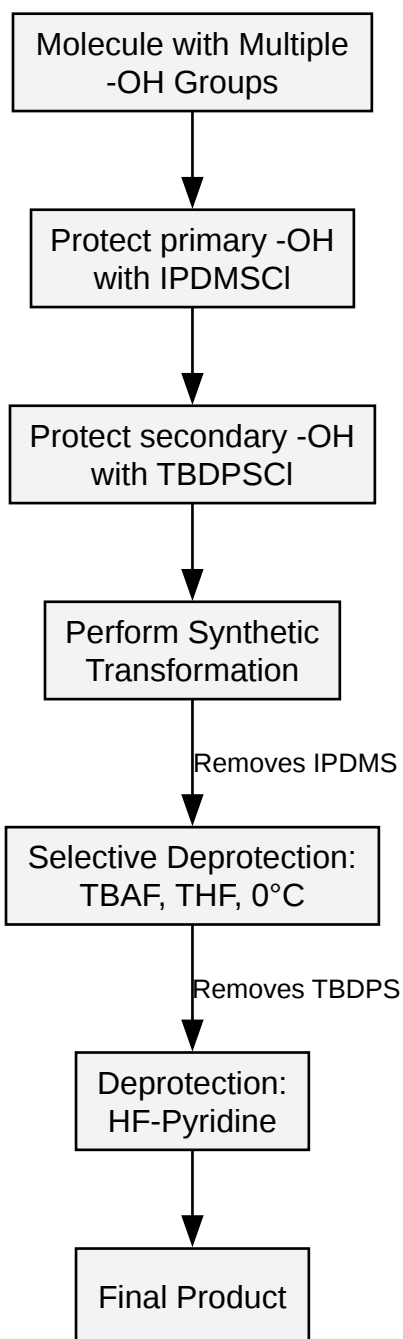

[Click to download full resolution via product page](#)

### Need Custom Synthesis?

BenchChem offers custom synthesis for rare earth carbides and specific isotopic labeling.

Email: [info@benchchem.com](mailto:info@benchchem.com) or [Request Quote Online](#).

## Sources

- [1. benchchem.com \[benchchem.com\]](#)
- [2. tandfonline.com \[tandfonline.com\]](#)
- [3. benchchem.com \[benchchem.com\]](#)
- [4. masterorganicchemistry.com \[masterorganicchemistry.com\]](#)
- [5. chem.libretexts.org \[chem.libretexts.org\]](#)
- [6. labs.utsouthwestern.edu \[labs.utsouthwestern.edu\]](#)
- [7. benchchem.com \[benchchem.com\]](#)
- [8. benchchem.com \[benchchem.com\]](#)
- [9. nbinno.com \[nbinno.com\]](#)
- [10. Deprotection of Silyl Ethers - Gelest \[technical.gelest.com\]](#)
- [11. Silyl ether - Wikipedia \[en.wikipedia.org\]](#)
- [12. benchchem.com \[benchchem.com\]](#)
- [13. chem.libretexts.org \[chem.libretexts.org\]](#)
- [14. Benzoyldiisopropylchlorosilane: a visible light photocleavable alcohol protecting group - PMC \[pmc.ncbi.nlm.nih.gov\]](#)
- [15. researchgate.net \[researchgate.net\]](#)
- [16. tert-Butyldimethylsilyl Ethers \[organic-chemistry.org\]](#)
- [17. Alcohol or phenol synthesis by silyl ether cleavage \[organic-chemistry.org\]](#)
- [18. researchgate.net \[researchgate.net\]](#)
- To cite this document: BenchChem. [Application Notes & Protocols: A Detailed Guide to Alcohol Protection Using Isopropyldimethylchlorosilane]. BenchChem, [2026]. [Online PDF]. Available at: [<https://www.benchchem.com/product/b1588863/docs#application-notes-protocols-a-detailed-guide-to-alcohol-protection-using-isopropyldimethylchlorosilane>]

---

### Disclaimer & Data Validity:

The information provided in this document is for Research Use Only (RUO) and is strictly not intended for diagnostic or therapeutic procedures. While BenchChem strives to provide

accurate protocols, we make no warranties, express or implied, regarding the fitness of this product for every specific experimental setup.

**Technical Support:** The protocols provided are for reference purposes. Unsure if this reagent suits your experiment?

**Need Industrial/Bulk Grade?** [Request Custom Synthesis Quote](#)

## BenchChem

Our mission is to be the trusted global source of essential and advanced chemicals, empowering scientists and researchers to drive progress in science and industry.

### Contact

Address: 3281 E Guasti Rd

Ontario, CA 91761, United States

Phone: (601) 213-4426

Email: [info@benchchem.com](mailto:info@benchchem.com)

[Contact our Ph.D. Support Team for a compatibility check](#)