

Technical Support Center: Accelerating Thionation Reactions

Author: BenchChem Technical Support Team. **Date:** May 2026

Compound of Interest

Compound Name: *Methyl 3-amino-3-thioxopropanoate*

CAS No.: 689-09-8

Cat. No.: B1587162

[Get Quote](#)

Welcome to the technical support center for thionation reactions. This guide is designed for researchers, scientists, and drug development professionals who are looking to optimize their thionation processes, with a specific focus on increasing reaction rates and troubleshooting common issues. As Senior Application Scientists, we have compiled our expertise and field-proven insights to help you navigate the complexities of these reactions.

Frequently Asked Questions (FAQs)

Here we address some of the most common questions we receive about thionation reactions.

Q1: What is the fundamental mechanism of thionation using reagents like Lawesson's reagent?

The generally accepted mechanism for thionation of a carbonyl compound with Lawesson's reagent (LR) involves a few key steps. Initially, the LR dissociates into a reactive dithiophosphine ylide. This ylide then undergoes a [2+2] cycloaddition with the carbonyl group to form a four-membered oxaphosphetane intermediate. This intermediate subsequently undergoes cycloreversion to yield the desired thione and a phosphine oxide byproduct. The

rate-determining step is often the initial cycloaddition, which can be influenced by the electrophilicity of the carbonyl carbon.

Q2: My thionation reaction is very slow. What are the primary factors I should investigate?

Several factors can contribute to a slow thionation reaction. The most common culprits are:

- **Low Temperature:** Many thionation reactions require elevated temperatures to proceed at a reasonable rate.
- **Inappropriate Solvent:** The choice of solvent is critical. Aprotic, high-boiling solvents like toluene or xylene are often preferred.
- **Reagent Reactivity:** Not all thionating reagents are created equal. The reactivity of the chosen reagent plays a significant role.
- **Substrate Electronics:** Electron-rich carbonyls tend to react slower than electron-poor ones.

Q3: Is Lawesson's reagent the best choice for all thionation reactions?

While Lawesson's reagent is a versatile and widely used thionating agent, it may not always be the optimal choice. For substrates that are sensitive to high temperatures, other reagents like Belleau's reagent might be more suitable as they can be used under milder conditions. For large-scale reactions, the less expensive but often more challenging to handle phosphorus pentasulfide (P₄S₁₀) might be considered.

Q4: Can I use a catalyst to speed up my thionation reaction?

Yes, catalytic approaches to thionation are an emerging area. While traditional methods are often stoichiometric, research has shown that certain catalysts can be employed. For example, the use of catalytic amounts of P₄S₁₀ with a stoichiometric amount of a milder sulfur source has been reported. Additionally, microwave irradiation can significantly accelerate thionation reactions, often leading to shorter reaction times and cleaner reaction profiles.

Troubleshooting Guide for Sluggish Thionation Reactions

This section provides a structured approach to diagnosing and resolving issues with slow or incomplete thionation reactions.

Problem 1: The reaction has stalled or is proceeding very slowly.

Probable Cause	Suggested Solution	Scientific Rationale
Insufficient Temperature	Gradually increase the reaction temperature, monitoring for product formation and potential side reactions. Consider switching to a higher-boiling solvent if necessary.	The initial [2+2] cycloaddition step in thionation often has a significant activation energy barrier. Increasing the temperature provides the necessary energy to overcome this barrier, thus increasing the reaction rate.
Poor Reagent Solubility	If using a heterogeneous mixture (e.g., with P4S10), ensure vigorous stirring. For reagents like Lawesson's, consider a solvent in which it has better solubility at the reaction temperature, such as anhydrous toluene or dioxane.	For a reaction to occur, the reactants must be able to interact. Poor solubility of the thionating agent can limit its effective concentration in the solution, leading to a slower reaction rate.
Low Reagent Reactivity	If temperature and solvent optimization are ineffective, consider a more reactive thionating agent. For example, if Lawesson's reagent is too slow, the more reactive Belleau's reagent could be an option.	Different thionating reagents have varying levels of reactivity due to their electronic and steric properties. A more reactive reagent can accelerate the rate-determining step of the reaction.
Deactivated Substrate	For electron-rich carbonyls, a more forceful thionating agent or higher temperatures may be required.	The electrophilicity of the carbonyl carbon is a key driver of the reaction. Electron-donating groups on the substrate reduce this electrophilicity, making the nucleophilic attack by the thionating agent less favorable.

Problem 2: The reaction is producing significant side products.

Probable Cause	Suggested Solution	Scientific Rationale
Reaction Temperature is Too High	If the desired product is thermally unstable, or if side reactions are observed at higher temperatures, try running the reaction at the lowest effective temperature.	While high temperatures can increase the rate of the desired reaction, they can also accelerate undesirable side reactions, such as decomposition of the starting material or product.
Presence of Water	Ensure all glassware is oven-dried and that anhydrous solvents are used. Perform the reaction under an inert atmosphere (e.g., nitrogen or argon).	Thionating reagents are moisture-sensitive and can be hydrolyzed by water. This not only consumes the reagent but can also generate byproducts that complicate the reaction mixture.
Incorrect Stoichiometry	Carefully control the stoichiometry of the thionating reagent. An excess can sometimes lead to side reactions with other functional groups in the molecule.	Using the correct molar equivalents of the thionating agent is crucial. An excess can lead to over-thionation or reaction with other susceptible functional groups.

Visualizing the Thionation Process

To aid in understanding the reaction and troubleshooting, we have provided the following diagrams.

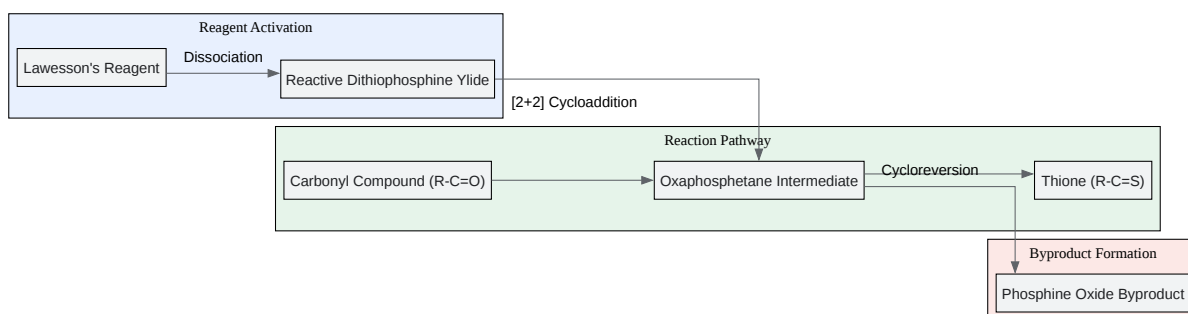

[Click to download full resolution via product page](#)

Caption: General mechanism of thionation using Lawesson's reagent.

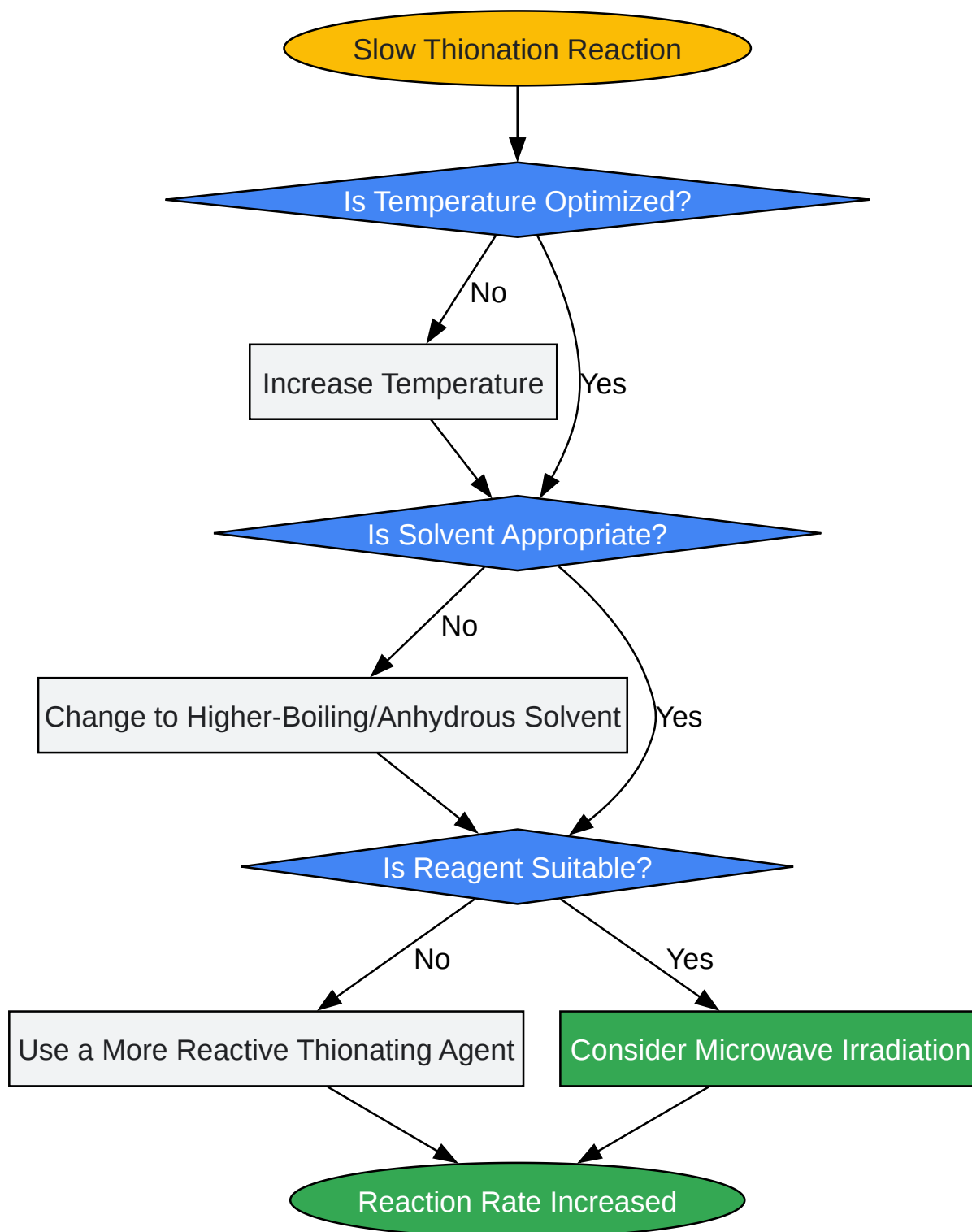

[Click to download full resolution via product page](#)

Caption: Decision workflow for troubleshooting a slow thionation reaction.

Detailed Experimental Protocol: Thionation of an Amide

This protocol provides a general procedure for the thionation of a secondary amide using Lawesson's reagent.

Materials:

- Secondary amide (1.0 eq)
- Lawesson's reagent (0.5 eq)
- Anhydrous toluene
- Round-bottom flask
- Reflux condenser
- Magnetic stirrer and stir bar
- Heating mantle
- Inert gas supply (Nitrogen or Argon)

Procedure:

- **Setup:** Assemble the glassware and ensure it is oven-dried. The reaction should be set up under an inert atmosphere.
- **Charging the Flask:** To the round-bottom flask, add the secondary amide and anhydrous toluene. Stir the mixture until the amide is fully dissolved.
- **Adding the Reagent:** Add Lawesson's reagent to the flask in one portion. Note that Lawesson's reagent may not fully dissolve at room temperature.
- **Reaction:** Heat the reaction mixture to reflux (approximately 110 °C for toluene) and maintain this temperature.

- **Monitoring:** Monitor the progress of the reaction by thin-layer chromatography (TLC) or liquid chromatography-mass spectrometry (LC-MS).
- **Work-up:** Once the reaction is complete, cool the mixture to room temperature. The crude product can be purified by filtration to remove any insoluble byproducts, followed by column chromatography on silica gel.

Comparison of Common Thionating Reagents

Reagent	Formula	Typical Conditions	Advantages	Disadvantages
Lawesson's Reagent	C ₁₄ H ₁₄ O ₂ P ₂ S ₄	Toluene or xylene, reflux	Good reactivity, commercially available	Can require high temperatures, byproduct removal can be tricky
Phosphorus Pentasulfide	P ₄ S ₁₀	Toluene, pyridine, reflux	Inexpensive	Heterogeneous, can be difficult to handle, often requires a base
Belleau's Reagent	C ₁₆ H ₁₈ N ₂ O ₂ P ₂ S ₄	THF, room temp to reflux	Milder reaction conditions	More expensive than Lawesson's reagent
Davy Reagents	Varies	Varies	Tunable reactivity	Not as commonly used or commercially available as Lawesson's reagent

References

- Ozturk, T., Ertas, E., & Mert, O. (2010). A Berzelius Reagent, Phosphorus Decasulfide (P₄S₁₀), in Organic Syntheses. Chemical Reviews, 110(6), 3419-3478. [\[Link\]](#)

- Fossey, J. S., & Richards, C. J. (2004). Microwave-accelerated thionation of carbonyls with Lawesson's reagent. *Tetrahedron Letters*, 45(41), 7949-7951. [[Link](#)]
- Kalman, A., Czugler, M., & Toth, G. (1981). On the structure of Belleau's reagent. *Journal of Molecular Structure*, 77(1-2), 279-282. [[Link](#)]
- Varma, R. S. (1999). Solvent-free organic syntheses. Using supported reagents and microwave irradiation. *Green Chemistry*, 1(1), 43-55. [[Link](#)]
- To cite this document: BenchChem. [Technical Support Center: Accelerating Thionation Reactions]. BenchChem, [2026]. [Online PDF]. Available at: [<https://www.benchchem.com/product/b1587162/docs#technical-support-center-accelerating-thionation-reactions>]

Disclaimer & Data Validity:

The information provided in this document is for Research Use Only (RUO) and is strictly not intended for diagnostic or therapeutic procedures. While BenchChem strives to provide accurate protocols, we make no warranties, express or implied, regarding the fitness of this product for every specific experimental setup.

Technical Support: The protocols provided are for reference purposes. Unsure if this reagent suits your experiment?

Need Industrial/Bulk Grade? [Request Custom Synthesis Quote](#)

BenchChem

Our mission is to be the trusted global source of essential and advanced chemicals, empowering scientists and researchers to drive progress in science and industry.

Contact

Address: 3281 E Guasti Rd
Ontario, CA 91761, United States
Phone: (601) 213-4426
Email: info@benchchem.com

Contact our Ph.D. Support Team for a compatibility check