

# Technical Support Center: ATRP Using Allyl 2-bromo-2-methylpropionate

**Author:** BenchChem Technical Support Team. **Date:** May 2026

## Compound of Interest

Compound Name: *Allyl 2-bromo-2-methylpropionate*

CAS No.: 40630-82-8

Cat. No.: B1587140

[Get Quote](#)

Welcome to the technical support center for Atom Transfer Radical Polymerization (ATRP) utilizing **Allyl 2-bromo-2-methylpropionate**. This guide is designed for researchers, scientists, and drug development professionals to navigate the complexities and potential pitfalls of using this versatile, functional initiator. Here, we will dissect common experimental issues, provide evidence-based troubleshooting protocols, and explain the underlying chemical principles to ensure your polymerizations are controlled, efficient, and reproducible.

## Introduction to Allyl 2-bromo-2-methylpropionate in ATRP

**Allyl 2-bromo-2-methylpropionate** is a valuable initiator for ATRP as it installs a reactive allyl group at the  $\alpha$ -terminus of the polymer chain.[1] This functionality serves as a versatile handle for post-polymerization modifications, such as thiol-ene reactions or hydrosilylation, enabling the synthesis of complex macromolecular architectures.[1] However, the presence of the allyl group, an unconjugated double bond, can also introduce a series of potential side reactions that may compromise the "living" character of the polymerization, leading to loss of control over molecular weight, broad molecular weight distributions, and even gelation.[2][3]

This guide will address these challenges in a practical, question-and-answer format, empowering you to diagnose and resolve common issues encountered in your experiments.

## Core Principles of ATRP

Before delving into troubleshooting, it's crucial to recall the fundamental equilibrium of ATRP. The process relies on the reversible activation of a dormant species (the polymer chain with a terminal halogen) by a transition metal complex (typically copper(I)) to form a propagating radical and the oxidized metal complex (copper(II)).<sup>[1][4][5]</sup> A low concentration of radicals is maintained to minimize termination reactions.<sup>[6]</sup>

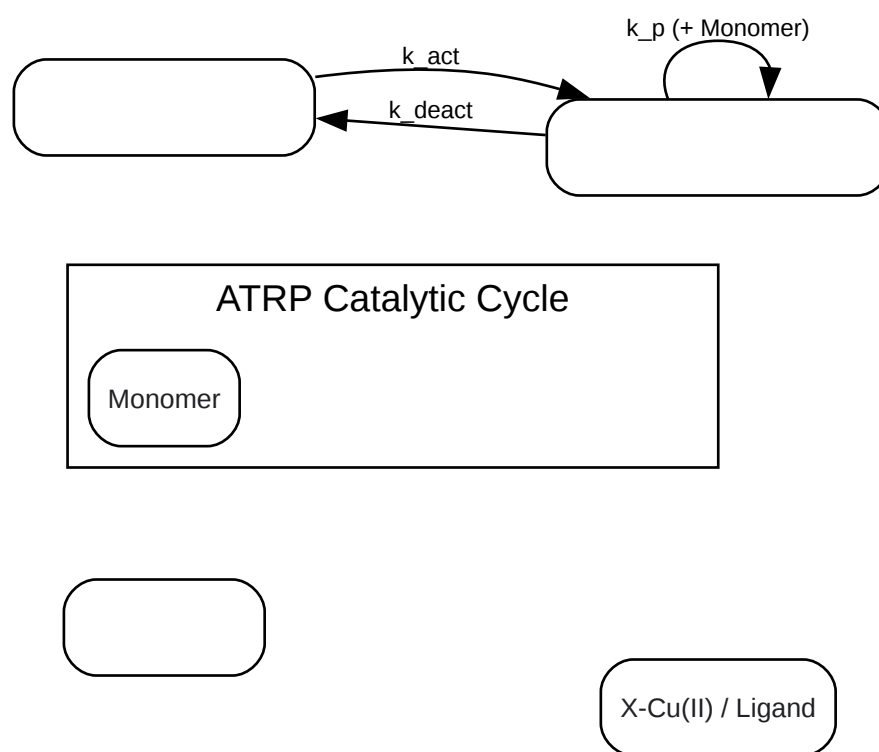

[Click to download full resolution via product page](#)

Caption: The core ATRP catalytic cycle.

## Troubleshooting Guide

### Issue 1: Bimodal or Broad Molecular Weight Distribution in GPC Traces

Question: I'm observing a bimodal or significantly broadened molecular weight distribution in my GPC results when using **Allyl 2-bromo-2-methylpropionate**. What could be the cause, and how can I fix it?

Answer: A bimodal or broad molecular weight distribution is a classic symptom of loss of control in the polymerization. With an allyl-functionalized initiator, there are several potential culprits:

- Cause A: Oxidative Alkyne-Alkyne Coupling (if using a propargyl analogue): While your initiator is allyl-functional, a very similar and common issue arises with the analogous propargyl 2-bromo-2-methylpropanoate, where terminal alkynes undergo oxidative coupling under ATRP conditions, leading to bimodal distributions.[7] It is crucial to ensure you are using the correct allyl initiator.
- Cause B: Chain Transfer to the Allyl Group: The allyl protons are susceptible to abstraction by the propagating radical, creating a new, less reactive radical on the initiator fragment and terminating the original chain. This new radical can then initiate a new polymer chain, leading to a population of polymers with different initiation points and thus a broader molecular weight distribution.
- Cause C: Radical Addition to the Allyl Double Bond: The propagating radical can add across the double bond of the allyl group on another polymer chain.[2] This branching reaction can lead to higher molecular weight species and a broadening of the distribution. At higher conversions, this can lead to cross-linking and gel formation.[2][3]
- Cause D: Inefficient Initiation: If the rate of initiation is significantly slower than the rate of propagation, new chains will be formed throughout the polymerization, resulting in a broad distribution of chain lengths.[8][9]

Troubleshooting Protocol:

- Verify Initiator Purity:
  - Action: Confirm the identity and purity of your **Allyl 2-bromo-2-methylpropionate** initiator using  $^1\text{H}$  NMR and  $^{13}\text{C}$  NMR spectroscopy.
  - Rationale: Impurities can act as unintended initiators or inhibitors, disrupting the controlled nature of the polymerization.

- Optimize Reaction Temperature:
  - Action: Lower the reaction temperature. For monomers like methacrylates, temperatures around 50-70°C are often a good starting point.
  - Rationale: Side reactions, such as chain transfer and radical addition to the allyl group, have higher activation energies than propagation.[2] Lowering the temperature will disproportionately slow these undesired reactions compared to chain growth, improving control.
- Increase Catalyst Deactivator Concentration:
  - Action: Add a small amount of the Cu(II) complex (e.g., CuBr<sub>2</sub>/Ligand) at the beginning of the reaction (typically 5-10 mol% relative to the Cu(I) catalyst).
  - Rationale: This increases the concentration of the deactivator, shifting the ATRP equilibrium towards the dormant species.[5] This lowers the overall radical concentration, reducing the probability of bimolecular termination and side reactions involving the allyl group.[6]
- Choose a More Active Catalyst System:
  - Action: Employ a more active catalyst system, such as one with a ligand like Me<sub>6</sub>TREN or TPMA.
  - Rationale: A more active catalyst will lead to a faster deactivation rate (higher  $k_{\text{deact}}$ ), which helps to suppress side reactions by keeping the radical concentration low and ensuring rapid reversible deactivation.[1]

Summary of Troubleshooting Strategies for Broad MWD:

Parameter	Recommended Adjustment	Rationale
Temperature	Decrease	Reduce rate of side reactions relative to propagation.
[Cu(II)] <sub>0</sub>	Increase (add 5-10% at t=0)	Lower radical concentration to minimize termination.
Catalyst System	Use more active ligand (e.g., Me <sub>6</sub> TREN)	Promote faster deactivation and better control.
Monomer Conversion	Target lower conversion	Minimize branching and cross-linking at later stages.

## Issue 2: Polymerization Stalls at Low Conversion or is Unusually Slow

Question: My ATRP reaction with **Allyl 2-bromo-2-methylpropionate** is extremely slow or stops completely at low monomer conversion. What's happening?

Answer: A stalled or overly slow polymerization points to issues with the catalyst activity or the presence of inhibitors.

- Cause A: Catalyst Oxidation: The Cu(I) activator is sensitive to oxidation by residual oxygen in the reaction system. If your deoxygenation procedure is not thorough, the Cu(I) will be converted to the inactive Cu(II) state, effectively stopping the polymerization.
- Cause B: Impurities in Monomer or Solvent: Monomers often contain inhibitors (like MEHQ) that must be removed. Solvents can also contain impurities that can coordinate with the copper catalyst and reduce its activity.
- Cause C: Poor Initiator Efficiency: While **Allyl 2-bromo-2-methylpropionate** is generally an efficient initiator, its efficiency can be affected by the specific monomer and reaction conditions.[\[10\]](#)

Troubleshooting Protocol:

- Rigorous Deoxygenation:

- Action: Ensure all components (monomer, solvent, initiator) are thoroughly deoxygenated before mixing. A minimum of three freeze-pump-thaw cycles is recommended for the reaction mixture. Alternatively, sparging with an inert gas (Argon or Nitrogen) for at least 30-60 minutes can be effective.
- Rationale: Oxygen irreversibly oxidizes the Cu(I) catalyst to Cu(II), halting the activation of dormant chains.
- Purification of Reagents:
  - Action: Pass the monomer through a column of basic alumina to remove the inhibitor. Use freshly distilled or high-purity anhydrous solvents.
  - Rationale: Inhibitors scavenge radicals, preventing polymerization. Coordinating impurities in solvents can poison the catalyst.
- Employ an Activator Regeneration Technique (e.g., ARGET or ICAR ATRP):
  - Action: Introduce a reducing agent (for ARGET ATRP) or a conventional radical initiator (for ICAR ATRP) to continuously regenerate the Cu(I) activator from the Cu(II) deactivator that builds up due to termination reactions.[\[11\]](#)
  - Rationale: These techniques allow for the use of much lower catalyst concentrations (ppm levels) and are more tolerant to oxygen, as they have a built-in mechanism to counteract catalyst oxidation.[\[11\]](#)[\[12\]](#)

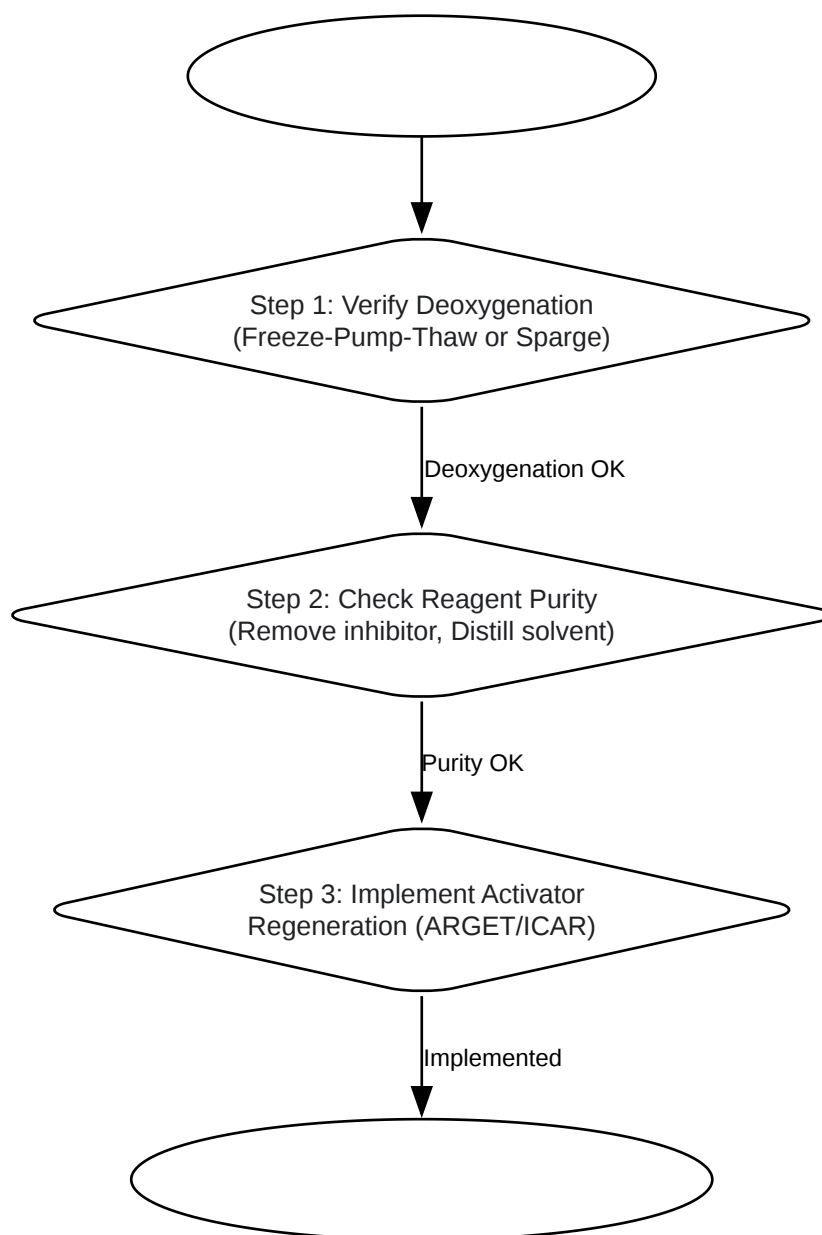

[Click to download full resolution via product page](#)

Caption: Troubleshooting workflow for slow ATRP reactions.

## Frequently Asked Questions (FAQs)

Q1: Can the allyl group itself polymerize under ATRP conditions?

The reactivity of the allyl double bond is significantly lower than that of common ATRP monomers like acrylates and methacrylates.[2] Under carefully controlled conditions (e.g., lower temperatures), the polymerization will proceed selectively through the monomer's double

bond, leaving the allyl group intact.[3] However, at higher temperatures or high monomer conversions, the probability of side reactions involving the allyl group increases.[2]

Q2: I observe some insoluble gel in my reaction flask at high conversion. Why?

This is likely due to cross-linking.[3] As the concentration of polymer chains bearing allyl groups increases, the chance of a propagating radical from one chain adding to an allyl group on another chain rises. This creates a covalent link between chains, and enough of these events will lead to an insoluble polymer network (gel). To avoid this, it is often best to stop the polymerization at moderate conversions (e.g., 50-70%) if you are targeting a soluble, linear polymer.

Q3: Are there alternative initiators to introduce an allyl group with fewer side reactions?

While **Allyl 2-bromo-2-methylpropionate** is widely used, you could consider a protected functional group strategy. For example, use an initiator with a protected hydroxyl group, carry out the ATRP, and then deprotect the hydroxyl and convert it to an allyl ether in a post-polymerization step. This adds synthetic steps but completely decouples the potentially problematic allyl group from the polymerization itself.

Q4: How does the choice of solvent affect side reactions with the allyl group?

The solvent can influence the ATRP equilibrium and catalyst stability. In protic media like water or alcohols, side reactions such as the disproportionation of the Cu(I) complex can occur, leading to a loss of control.[13] For polymerizations with functional initiators like this, using a non-polar or moderately polar aprotic solvent (e.g., toluene, anisole, DMF) often provides a more stable and controlled environment.

## References

- ATRP of Allyl Methacrylate with Alkyl Methacrylates – Crosslinking of Poly(methacrylate)s with Allyl Ester Side Groups. ResearchGate. Available from: [\[Link\]](#)
- Synthesis and Applications of ATRP Macromolecular Initiator. Scientific.Net. Available from: [\[Link\]](#)
- What is the mechanism for ATRP? Reddit. Available from: [\[Link\]](#)

- Functional polymers by atom transfer radical polymerization. Progress in Polymer Science. Available from: [\[Link\]](#)
- Atom Transfer Radical Polymerization (ATRP): Current Status and Future Perspectives. ACS Publications. Available from: [\[Link\]](#)
- Atom transfer radical polymerization. Wikipedia. Available from: [\[Link\]](#)
- Activating ATRP Initiators to Incorporate End-Group Modularity into Photo-RAFT Polymerization. ACS Publications. Available from: [\[Link\]](#)
- Macromolecular Engineering by Applying Concurrent Reactions with ATRP. MDPI. Available from: [\[Link\]](#)
- Atom Transfer Radical Polymerization. ACS Publications. Available from: [\[Link\]](#)
- Effects of Initiator Structure on Activation Rate Constants in ATRP. ResearchGate. Available from: [\[Link\]](#)
- Atom Transfer Radical Polymerization. Matyjaszewski Polymer Group, Carnegie Mellon University. Available from: [\[Link\]](#)
- ATRP in Protic Media. Matyjaszewski Polymer Group, Carnegie Mellon University. Available from: [\[Link\]](#)
- Synthesis of Polymers Containing Cross-Linkable Groups by Atom Transfer Radical Polymerization: Poly(allyl methacrylate) and Copolymers of Allyl Methacrylate and Styrene. ResearchGate. Available from: [\[Link\]](#)
- Kinetic Studies on ATRP. Matyjaszewski Polymer Group, Carnegie Mellon University. Available from: [\[Link\]](#)
- One-Pot Synthesis of Star Copolymers by the Combination of Metal-Free ATRP and ROP Processes. MDPI. Available from: [\[Link\]](#)
- Kris Matyjaszewski - Fundamentals of Controlled/Living Radical Polymerization. YouTube. Available from: [\[Link\]](#)

- Photoinitiated ATRP. Matyjaszewski Polymer Group, Carnegie Mellon University. Available from: [\[Link\]](#)
- Prop-2-yn-1-yl 2-Bromo-2-methylpropanoate: Identification and Suppression of Side Reactions of a Commonly Used Terminal Alkyne-Functional ATRP Initiator. ResearchGate. Available from: [\[Link\]](#)

### Need Custom Synthesis?

BenchChem offers custom synthesis for rare earth carbides and specific isotopic labeling.

Email: [info@benchchem.com](mailto:info@benchchem.com) or [Request Quote Online](#).

## Sources

- [1. ATRP Ligands & Initiators: Clean Functional Polymers \[sigmaaldrich.com\]](#)
- [2. researchgate.net \[researchgate.net\]](#)
- [3. polymer.chem.cmu.edu \[polymer.chem.cmu.edu\]](#)
- [4. Atom transfer radical polymerization - Wikipedia \[en.wikipedia.org\]](#)
- [5. Atom Transfer Radical Polymerization - Matyjaszewski Polymer Group - Carnegie Mellon University \[cmu.edu\]](#)
- [6. reddit.com \[reddit.com\]](#)
- [7. researchgate.net \[researchgate.net\]](#)
- [8. researchgate.net \[researchgate.net\]](#)
- [9. m.youtube.com \[m.youtube.com\]](#)
- [10. pubs.acs.org \[pubs.acs.org\]](#)
- [11. mdpi.com \[mdpi.com\]](#)
- [12. Photoinitiated ATRP - Matyjaszewski Polymer Group - Carnegie Mellon University \[cmu.edu\]](#)
- [13. ATRP in Protic Media - Matyjaszewski Polymer Group - Carnegie Mellon University \[cmu.edu\]](#)
- To cite this document: BenchChem. [Technical Support Center: ATRP Using Allyl 2-bromo-2-methylpropionate]. BenchChem, [2026]. [Online PDF]. Available at:

[<https://www.benchchem.com/product/b1587140/docs#technical-support-center-atrp-using-allyl-2-bromo-2-methylpropionate>]

### Disclaimer & Data Validity:

The information provided in this document is for Research Use Only (RUO) and is strictly not intended for diagnostic or therapeutic procedures. While BenchChem strives to provide accurate protocols, we make no warranties, express or implied, regarding the fitness of this product for every specific experimental setup.

**Technical Support:** The protocols provided are for reference purposes. Unsure if this reagent suits your experiment?

**Need Industrial/Bulk Grade?** [Request Custom Synthesis Quote](#)

## BenchChem

Our mission is to be the trusted global source of essential and advanced chemicals, empowering scientists and researchers to drive progress in science and industry.

### Contact

Address: 3281 E Guasti Rd  
Ontario, CA 91761, United States  
Phone: (601) 213-4426  
Email: [info@benchchem.com](mailto:info@benchchem.com)

[Contact our Ph.D. Support Team for a compatibility check](#)