

Technical Support Center: 3-Chloro-5-(trifluoromethyl)benzaldehyde Synthesis

Author: BenchChem Technical Support Team. **Date:** May 2026

Compound of Interest

Compound Name:	3-Chloro-5-(trifluoromethyl)benzaldehyde
CAS No.:	477535-43-6
Cat. No.:	B1587322

[Get Quote](#)

Topic: Troubleshooting Common Impurities & Process Optimization

Executive Summary & Critical Analysis

Synthesis of **3-Chloro-5-(trifluoromethyl)benzaldehyde** is a high-value workflow often plagued by specific impurity profiles dictated by the chosen synthetic route.[1][2] As a meta-substituted benzaldehyde with two electron-withdrawing groups (EWG), the aromatic ring is highly deactivated, making electrophilic aromatic substitution difficult and nucleophilic attacks (or metalations) highly sensitive to regiochemistry.[2]

This guide addresses the two primary synthetic methodologies:

- Metal-Halogen Exchange (Lithiation): Prone to regiochemical errors and hydrolysis byproducts.[1][2]
- Radical Chlorination/Hydrolysis (Side-chain Oxidation): Prone to redox impurities (alcohols/acids).[1][2]

Module A: The Lithiation Route (Regioselectivity & Moisture)[1][2]

User Scenario: "I used n-BuLi with 1-chloro-3-(trifluoromethyl)benzene followed by DMF, but NMR shows a mixture of isomers. Why isn't the reaction selective for the 5-position?"

Technical Insight: The "Directing Group" Trap

This is the most common error. You cannot access the 3,5-position via Direct Ortho-Metalation (DoM) of the parent chloro-trifluoromethylbenzene.[2]

- Mechanism: Both -Cl and -CF₃ are Ortho-Directing Groups (ODG) in lithiation chemistry due to the inductive acidification of adjacent protons.[1][2]
- The Result: Treatment of 1-chloro-3-(trifluoromethyl)benzene with n-BuLi/LDA will exclusively lithiate at the 2-position (between Cl and CF₃) or the 6-position (ortho to CF₃).[1][2] It will not touch the 5-position (meta to both).[2]

Solution: You must use Halogen-Lithium Exchange starting from 1-bromo-3-chloro-5-(trifluoromethyl)benzene.[1][2]

Troubleshooting Guide: Impurity Profile

Impurity Name	Structure Description	Origin/Cause	Removal Strategy
The "2-Isomer"	2-chloro-3-(trifluoromethyl)benzaldehyde	Wrong Mechanism: Result of DoM on the starting material instead of Br/Li exchange.[1][2]	Prevention: Ensure starting material is the bromo-analog. Keep temp < -78°C to prevent scrambling.
Protonated Precursor	1-chloro-3-(trifluoromethyl)benzene	Quenching Failure: Moisture entered before DMF addition, or incomplete Br/Li exchange.[1][2]	Purification: Bisulfite wash (see Module C). [1][2][3] This is non-polar and washes out.
The "Dimer"	3,3'-dichloro-5,5'-bis(trifluoromethyl)biphenyl	Wurtz Coupling: Alkyl halide (n-BuBr) generated in situ reacts with the aryllithium.[1][2]	Process Control: Use t-BuLi (2 equiv) or keep T < -78°C. Slow addition of n-BuLi.
The "Carbinol"	Bis(3-chloro-5-(trifluoromethyl)phenyl)methanol	Double Addition: The aryllithium reacts with the newly formed aldehyde.[1][2]	Process Control: Ensure excess DMF and rapid quenching.

Visualizing the Pathway (Graphviz)

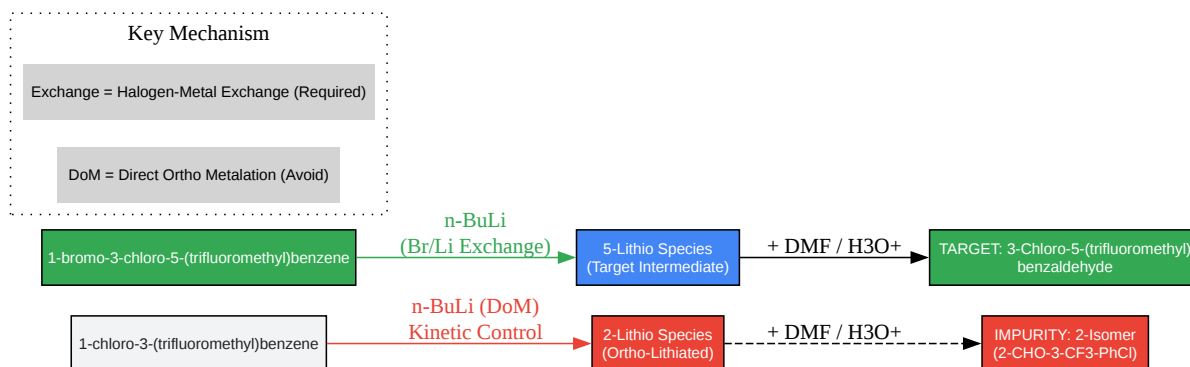

[Click to download full resolution via product page](#)

Figure 1: Divergent reaction pathways showing how incorrect starting material selection leads to regio-isomeric impurities.[1][2][4]

Module B: The Oxidation/Reduction Route (Redox Control)[1][2]

User Scenario: "I synthesized the aldehyde via hydrolysis of the benzal chloride, but the product is an oil with a broad melting point range. GC shows three major peaks."

Technical Insight: The Oxidation State Ladder

When synthesizing aldehydes via radical chlorination of toluene derivatives (followed by hydrolysis) or reduction of nitriles/acids, the system fights to stay at the aldehyde oxidation state.

- Over-Oxidation: Aldehydes autoxidize to Benzoic Acids rapidly in air, especially with electron-withdrawing groups like CF₃/Cl making the carbonyl carbon highly electrophilic.[2]
- Over-Reduction: If reducing an ester/nitrile, stopping at the aldehyde requires precise steric control (e.g., using DIBAL-H at -78°C).[1][2]

Troubleshooting Guide: Redox Impurities

Impurity Name	Detection (Typical)	Origin/Cause	Troubleshooting
The "Acid"	3-chloro-5-(trifluoromethyl)benzoic acid	HPLC: Short RT (Polar).[1][2] Odor: Acrid/Vinegar.[1][2]	Cause: Air exposure or over-chlorination (benzotrichloride formation).[2] Fix: Store under Argon. Wash organic layer with sat.[1][2][5] NaHCO ₃ .
The "Alcohol"	3-chloro-5-(trifluoromethyl)benzyl alcohol	HPLC: Broad peak.[1][2] IR: OH stretch ~3400 cm ⁻¹ . [1][2]	Cause: Over-reduction (if using DIBAL) or Cannizzaro reaction during basic hydrolysis.[2] Fix: Control hydrolysis pH (avoid strong base).
The "Acetal"	Diethyl acetal derivative	NMR: Triplet/Quartet (Ethyl groups).[1][2]	Cause: Quenching with Ethanol/Acid.[2] Fix: Use water/THF for quench, not alcohols.

Module C: The "Silver Bullet" Purification Protocol

User Scenario: "Distillation is causing decomposition, and column chromatography is too expensive for my 50g batch. How do I clean this?"

The Solution: Bisulfite Adduct Purification Aldehydes form solid, water-soluble adducts with sodium bisulfite (NaHSO₃).[1][2] Impurities like alcohols, starting halides, and dimers do not.[2] This is a self-validating purification system.[2]

Step-by-Step Protocol

- Adduct Formation:

- Dissolve crude oil in minimal Methanol or Ethanol (e.g., 2 volumes).[1][2]
- Add saturated aqueous Sodium Bisulfite (NaHSO_3) solution (1.5 equivalents).[2]
- Stir vigorously for 2–4 hours. A thick white precipitate (the adduct) should form.[1][2]
- Note: If no solid forms, the adduct may be soluble in the alcohol/water mix. Add more water or cool to 0°C .
- The Wash (Removing Impurities):
 - Filter the solid adduct.[6][7][8][9][10]
 - CRITICAL STEP: Wash the filter cake with Diethyl Ether or Hexanes.
 - Why? The filtrate and the ether wash contain your impurities (dimers, starting material, alcohols).[2] The solid filter cake is your protected aldehyde.
- Regeneration:
 - Suspend the white solid in water/DCM (biphasic).[1][2]
 - Slowly add Sodium Carbonate (Na_2CO_3) or dilute NaOH until $\text{pH} > 10$.[2]
 - Observation: The solid will dissolve, and the free aldehyde will migrate into the DCM layer.
 - Separate, dry (MgSO_4), and concentrate.[2][3]

Workflow Visualization (Graphviz)

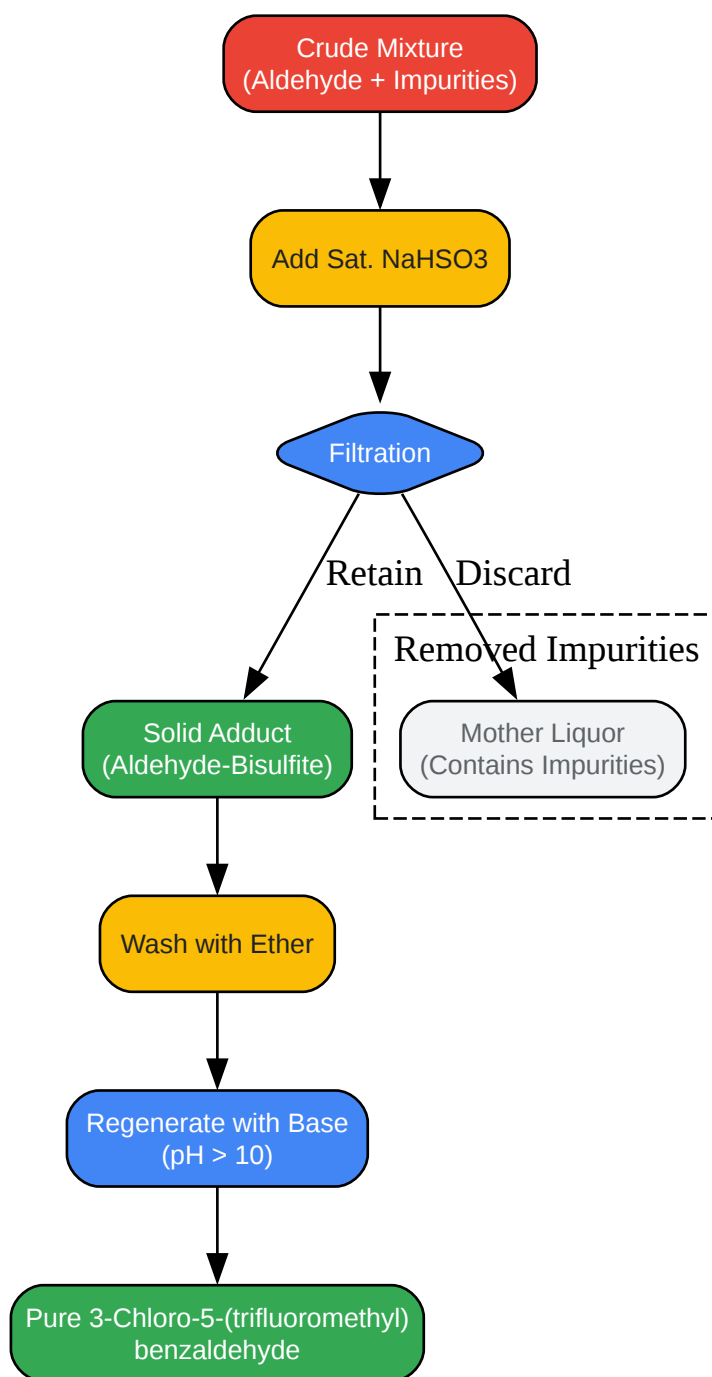

[Click to download full resolution via product page](#)

Figure 2: The Bisulfite Adduct purification loop, effectively separating non-carbonyl impurities from the target.[2]

FAQ: Rapid Fire Troubleshooting

Q: My aldehyde smells like vinegar and the melting point is low. A: You have significant Benzoic Acid contamination (autoxidation).[1][2] The CF₃ and Cl groups make this aldehyde very prone to oxidation. Action: Wash the organic solution with 10% NaHCO₃ to extract the acid as the benzoate salt before evaporating.

Q: I see a small peak at M+14 in the Mass Spec. A: This is likely the Methyl Ester impurity (if you came from the acid route via methanol) or a homologation artifact. If you used the lithiation route, check for Methylation if MeI was used nearby, though unlikely.[2] More probable is a transesterification artifact if quenched with methanol.

Q: Can I use Silica Gel chromatography? A: Yes, but be careful. Acidic silica can degrade acetals or catalyze oxidation.[2] Neutralize the silica with 1% Triethylamine (TEA) in the eluent to ensure stability during purification.

References

- Pfizer Limited. (1985).[1][2][3] Benzaldehyde derivative and process for its preparation (EP0145334A2).[1][2] European Patent Office.[2][3] [Link](#)
 - Relevance: Describes the synthesis of 2-chloro-3-trifluoromethylbenzaldehyde via lithiation, highlighting the regioselectivity of the ortho-position and the necessity of altern
- Collum, D. B., et al. (2005).[1][2] Regioselective Lithium Diisopropylamide-Mediated Ortholithiation of 1-Chloro-3-(trifluoromethyl)benzene.[1][2][11] Journal of the American Chemical Society. [Link](#)[2]
 - Relevance: Definitive mechanistic study proving that direct lithiation of the chloro-trifluoro precursor yields the 2- and 6-isomers, not the 5-isomer.[2]
- Guidechem. (n.d.).[1][2][12] Synthesis of Bis(trifluoromethyl)benzaldehyde intermediates.[1][2][3][5][12][Link](#)[1][2]
 - Relevance: Provides context on oxidation routes and radical chlorination methods for similar electron-deficient benzaldehydes.
- National Institutes of Health (NIH). (2021).[1][2] Fatty aldehyde bisulfite adducts as a purification handle.[1][6][7] PMC.[1][2] [Link](#)

- Relevance: Validates the bisulfite adduct method as a scalable, chromatography-free purification strategy for aldehydes.[2][6]

Need Custom Synthesis?

BenchChem offers custom synthesis for rare earth carbides and specific isotopic labeling.

Email: info@benchchem.com or [Request Quote Online](#).

Sources

- 1. PubChemLite - 3-chloro-5-(trifluoromethyl)benzaldehyde (C₈H₄ClF₃O) [pubchemlite.lcsb.uni.lu]
- 2. 3-(Trifluoromethyl)benzaldehyde synthesis - chemicalbook [chemicalbook.com]
- 3. patentimages.storage.googleapis.com [patentimages.storage.googleapis.com]
- 4. chemrxiv.org [chemrxiv.org]
- 5. Page loading... [guidechem.com]
- 6. Fatty aldehyde bisulfite adducts as a purification handle in ionizable lipid synthesis - PMC [pmc.ncbi.nlm.nih.gov]
- 7. Fatty aldehyde bisulfite adducts as a purification handle in ionizable lipid synthesis - RSC Advances (RSC Publishing) [pubs.rsc.org]
- 8. sites.wp.odu.edu [sites.wp.odu.edu]
- 9. CN113429276A - Green process synthesis method of 3,4, 5-trimethoxybenzaldehyde - Google Patents [patents.google.com]
- 10. US4162269A - Purification process for 3-phenoxybenzaldehyde - Google Patents [patents.google.com]
- 11. pubs.acs.org [pubs.acs.org]
- 12. US20010014759A1 - Process for the preparation of 3,5-bis(trifluoro-methyl)-benzoyl chlorides and novel 3,5-bis(tri-halogenomethyl)-and 3,5-dimethylbenzoyl halides - Google Patents [patents.google.com]
- To cite this document: BenchChem. [Technical Support Center: 3-Chloro-5-(trifluoromethyl)benzaldehyde Synthesis]. BenchChem, [2026]. [Online PDF]. Available at: [<https://www.benchchem.com/product/b1587322/docs#technical-support-center-3-chloro-5-trifluoromethyl-benzaldehyde-synthesis>]

Disclaimer & Data Validity:

The information provided in this document is for Research Use Only (RUO) and is strictly not intended for diagnostic or therapeutic procedures. While BenchChem strives to provide accurate protocols, we make no warranties, express or implied, regarding the fitness of this product for every specific experimental setup.

Technical Support: The protocols provided are for reference purposes. Unsure if this reagent suits your experiment?

Need Industrial/Bulk Grade? [Request Custom Synthesis Quote](#)

BenchChem

Our mission is to be the trusted global source of essential and advanced chemicals, empowering scientists and researchers to drive progress in science and industry.

Contact

Address: 3281 E Guasti Rd

Ontario, CA 91761, United States

Phone: (601) 213-4426

Email: info@benchchem.com

[Contact our Ph.D. Support Team for a compatibility check](#)