

Technical Guide: Optimizing Yield in Phenylthiomethylation Cross-Coupling

Author: BenchChem Technical Support Team. **Date:** April 2026

Compound of Interest

Compound Name: 4,4,5,5-TETRAMETHYL-2-PHENYLSULFANYLMETHANE
CAS No.: 66080-23-7
Cat. No.: B1587145

[Get Quote](#)

Support Ticket System: Troubleshooting & Optimization

To: Research & Development Division From: Senior Application Scientist, Catalysis Group

Subject: Optimization Protocols for Phenylthiomethylation (

)

Executive Summary & Core Mechanism

Phenylthiomethylation involves introducing the

moiety onto an aromatic ring. While nucleophilic substitution (using

) is common, transition-metal catalyzed cross-coupling (Suzuki-Miyaura type) is preferred for complex drug scaffolds to avoid harsh basic conditions.

The standard reaction couples an Aryl Boronic Acid with Chloromethyl Phenyl Sulfide (

).

The "Hidden" Challenge: Catalyst Poisoning

Unlike standard alkyl halide couplings, this reaction fights two enemies:

- Sulfur Poisoning: The sulfur atom in the reactant and product is a soft Lewis base that binds strongly to soft Pd(II) intermediates, creating "off-cycle" resting states that kill turnover.
- Reagent Instability:

is hydrolytically unstable.

Visualizing the Failure Points

The following diagram maps the catalytic cycle and identifies exactly where the reaction typically fails (The "Bugs").

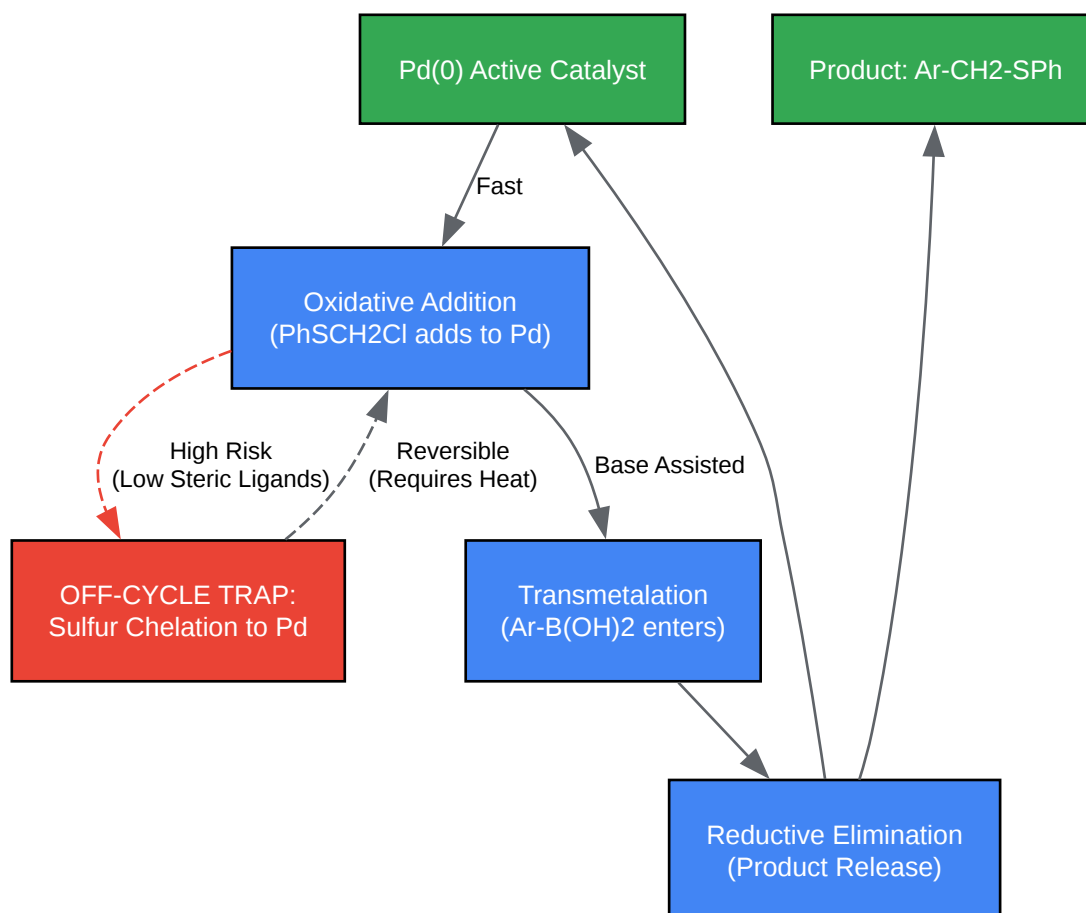

[Click to download full resolution via product page](#)

Figure 1: The Phenylthiomethylation Catalytic Cycle. Note the critical "Off-Cycle Trap" where sulfur coordinates to Palladium, necessitating bulky ligands to prevent catalyst death.

Troubleshooting Guide (Ticket-Based)

Ticket #001: "Reaction stalls at 40-50% conversion."

Diagnosis: Catalyst Deactivation (Sulfur Poisoning). The sulfur atom in your product is coordinating to the Palladium center, shutting down the catalytic cycle. Standard ligands like are not bulky enough to prevent this.

The Fix: Ligand Switch & Loading Switch to electron-rich, sterically demanding Buchwald ligands. These bulky ligands create a "protective shell" around the Pd center, preventing the sulfur atom from binding.

Parameter	Standard (Fail)	Optimized (Pass)	Why?
Catalyst		or	Precursors for active Pd(0).
Ligand		XPhos or SPhos	Bulky biaryl ligands prevent S-coordination.
Ratio	1:2 (Pd:L)	1:1.5 (Pd:L)	Slight excess ligand stabilizes Pd(0).
Loading	1-3 mol%	5-8 mol%	Higher loading compensates for S-poisoning.

Protocol 1: High-Turnover Conditions

- Charge flask with Aryl Boronic Acid (1.2 equiv), (5 mol%), and XPhos (7.5 mol%).
- Add Solvent (Toluene/Water 10:1) and Base (

, 3.0 equiv).

- Degas (sparge with Ar for 10 min).

- Add

(1.0 equiv) last via syringe.

- Heat to 100°C for 12-16h.

Ticket #002: "My electrophile () smells wrong and yields are near zero."

Diagnosis: Reagent Hydrolysis. Chloromethyl phenyl sulfide is highly susceptible to hydrolysis by ambient moisture, releasing thiophenol (stench) and formaldehyde. If your reagent bottle has a crust or intense "rotten cabbage" smell, it has decomposed.

The Fix: Reagent Integrity & Drying

- Verification: Run a quick GC-MS or NMR of the starting material. If you see

(Thiophenol) or

(Disulfide), distill the reagent.

- Storage: Store

over activated 4Å molecular sieves at 4°C.

- Reaction: Use anhydrous solvents for the reagent stock solution.

Self-Validating Step:

- Before adding the catalyst: Mix your

and base in the solvent. Wait 10 mins. If the solution turns cloudy immediately (and you aren't using an insoluble base), you likely have significant moisture hydrolyzing the chloride.

Ticket #003: "I'm seeing significant homocoupling of my boronic acid."

Diagnosis: Oxidative Induced Homocoupling. This is a side reaction where two aryl boronic acids couple (

) instead of coupling with the sulfide. This is driven by the presence of Oxygen.

The Fix: Rigorous Degassing Standard "balloon purging" is often insufficient for sulfur-sensitive couplings because the reaction is slower, giving

more time to interfere.

Protocol 2: The "Freeze-Pump-Thaw" Alternative (Sparging) If you cannot freeze-pump-thaw:

- Sonicate the solvent mixture under vacuum for 5 minutes.
- Backfill with Argon.
- Sparge (bubble gas through liquid) vigorously with Argon for 15 minutes before adding the catalyst.
- Base Switch: If homocoupling persists, switch from Carbonate bases () to Fluoride bases () or (). Fluoride activation is often milder and less prone to promoting homocoupling in this specific system.

Decision Logic for Optimization

Use this flow to select the correct conditions based on your substrate's electronics.

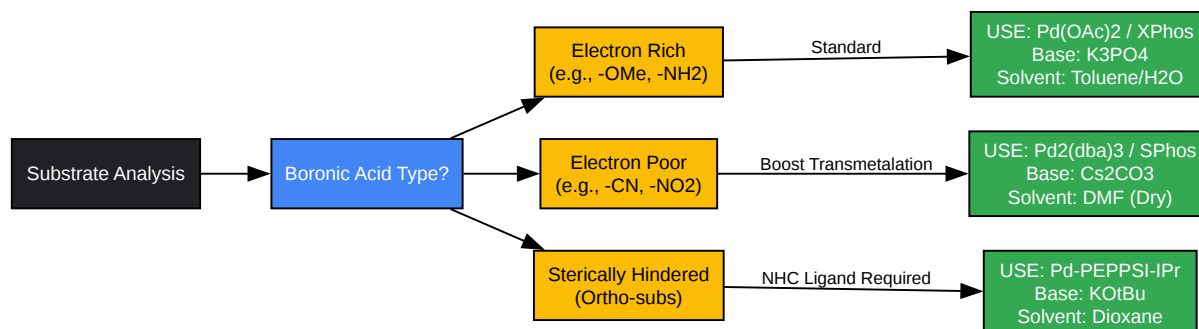

[Click to download full resolution via product page](#)

Figure 2: Optimization Decision Matrix based on Boronic Acid electronics and sterics.

FAQ: Rapid Response

Q: Can I use

(Stannane) instead of the chloride? A: Yes (Stille Coupling). It avoids the hydrolysis issue of the chloride but introduces toxicity and purification issues (tin residues). Use only if the Suzuki conditions fail due to boronic acid instability (protodeboronation).

Q: The reaction smells terrible. How do I clean the glassware? A: The smell is likely residual thiophenol or sulfide byproducts.

- Decontamination Protocol: Soak all glassware in a bath of Bleach (Sodium Hypochlorite) or Dilute

for 1 hour. This oxidizes the smelly sulfides to odorless sulfoxides/sulfones. Do not add acid to this bleach bath.

Q: Can I make the reagent

myself? A: Yes, but commercial is preferred for consistency.

- Synthesis: Thioanisole + Sulfuryl Chloride ()

- Warning: Distillation is required. If you skip distillation, the impurities will kill the Pd catalyst immediately.

References

- Suzuki-Miyaura Coupling with Alkyl Halides
 - Title: Palladium-Catalyzed Cross-Coupling Reactions of Alkyl Halides.[1][2][3][4]
 - Source:Chemical Reviews, 2008.
 - URL:[[Link](#)]
 - Relevance: Foundational mechanics of - coupling and suppression of -elimin
- Specifics of Chloromethyl Phenyl Sulfide
 - Title: Chloromethyl Phenyl Sulfide (Reagent Encyclopedia).[5]
 - Source:Encyclopedia of Reagents for Organic Synthesis (e-EROS).
 - URL:[[Link](#)]
 - Relevance: Handling, stability, and reactivity d
- Buchwald Ligands for C-S and C-C Bond Formation
 - Title: A General Catalyst for the Suzuki-Miyaura Cross-Coupling of Aryl Chlorides and/or Arylboronic Acids.
 - Source:Journal of the American Chemical Society, 2005.
 - URL:[[Link](#)]
 - Relevance: Establishes XPhos/SPhos as the gold standard for difficult couplings involving hetero

Need Custom Synthesis?

BenchChem offers custom synthesis for rare earth carbides and specific isotopic labeling.

Email: info@benchchem.com or [Request Quote Online](#).

Sources

- [1. Palladium/P,O-Ligand-Catalyzed Suzuki Cross-Coupling Reactions of Arylboronic Acids and Aryl Chlorides. Isolation and Structural Characterization of \(P,O\)-Pd\(dba\) Complex \[organic-chemistry.org\]](#)
- [2. d-nb.info \[d-nb.info\]](#)
- [3. A Palladium Catalyst System for the Efficient Cross-Coupling Reaction of Aryl Bromides and Chlorides with Phenylboronic Acid: Synthesis and Biological Activity Evaluation - PMC \[pmc.ncbi.nlm.nih.gov\]](#)
- [4. researchgate.net \[researchgate.net\]](#)
- [5. scientificlabs.ie \[scientificlabs.ie\]](#)
- [To cite this document: BenchChem. \[Technical Guide: Optimizing Yield in Phenylthiomethylation Cross-Coupling\]. BenchChem, \[2026\]. \[Online PDF\]. Available at: \[https://www.benchchem.com/product/b1587145/docs#technical-guide-optimizing-yield-in-phenylthiomethylation-cross-coupling\]](#)

Disclaimer & Data Validity:

The information provided in this document is for Research Use Only (RUO) and is strictly not intended for diagnostic or therapeutic procedures. While BenchChem strives to provide accurate protocols, we make no warranties, express or implied, regarding the fitness of this product for every specific experimental setup.

Technical Support: The protocols provided are for reference purposes. Unsure if this reagent suits your experiment?

Need Industrial/Bulk Grade? [Request Custom Synthesis Quote](#)

BenchChem

Our mission is to be the trusted global source of essential and advanced chemicals, empowering scientists and researchers to drive progress in science and industry.

Contact

Address: 3281 E Guasti Rd

Ontario, CA 91761, United States

Phone: (601) 213-4426

Email: info@benchchem.com

[Contact our Ph.D. Support Team for a compatibility check](#)