

Technical Guide: Mechanism of Hydrolysis for Chloromethyl(methyl)dimethoxysilane (CMDMS)

Author: BenchChem Technical Support Team. **Date:** May 2026

Compound of Interest

Compound Name:	<i>Chloromethyl(methyl)dimethoxysilane</i>
CAS No.:	2212-11-5
Cat. No.:	B1587336

[Get Quote](#)

Executive Summary

Chloromethyl(methyl)dimethoxysilane (CMDMS, CAS: 2212-11-5) represents a unique class of bifunctional organosilanes used extensively in the synthesis of pharmaceutical intermediates and advanced materials. Unlike simple alkylalkoxysilanes, CMDMS possesses a chloromethyl functional group (

) directly attached to the silicon atom. This moiety introduces a strong electron-withdrawing inductive effect (-I effect), fundamentally altering the hydrolysis kinetics compared to its non-halogenated analog, dimethyldimethoxysilane (DMDMS).

This guide provides a rigorous mechanistic analysis of CMDMS hydrolysis, detailing the acid/base catalytic cycles, the stability of the C-Cl bond during sol-gel processing, and validated protocols for monitoring reaction progression.

Molecular Architecture & Reactivity Profile

To understand the hydrolysis mechanism, one must first analyze the electronic environment of the central silicon atom.

Parameter	Feature	Mechanistic Implication
Leaving Group	Methoxy ()	Small steric profile; hydrolyzes faster than ethoxy groups.
Stabilizing Group	Methyl ()	Provides minimal steric hindrance; electron-donating (+I).
Functional Group	Chloromethyl ()	Electron-withdrawing (-I). Increases electrophilicity of Si; reduces basicity of leaving group oxygens.
Geometry	Tetrahedral ()	Subject to backside nucleophilic attack (-Si).

Key Insight: The chloromethyl group is the "control knob" for this molecule. By withdrawing electron density from the silicon center, it makes the silicon more susceptible to nucleophilic attack (base catalysis) but renders the methoxy oxygens less basic, potentially retarding protonation (acid catalysis step 1).

Mechanistic Pathways

Hydrolysis of CMDMS proceeds via the replacement of methoxy groups with hydroxyl groups, eventually leading to condensation. The pathway is pH-dependent.[1][2]

Acid-Catalyzed Hydrolysis (Electrophilic Mechanism)

In acidic media (pH < 4), the reaction is driven by the protonation of the methoxy oxygen.

- Protonation: A hydronium ion (

) transfers a proton to the methoxy oxygen, creating a good leaving group (

).

- Note: The electron-withdrawing

group slightly destabilizes this protonated intermediate compared to DMDMS, potentially increasing the activation energy of this specific step.

- Nucleophilic Attack: Water attacks the silicon atom from the backside (-like).[3]
- Transition State: A pentacoordinate silicon intermediate forms (inversion of configuration is possible but less relevant for achiral CMDMS).
- Elimination: Methanol is expelled, and the silicon returns to a tetrahedral geometry.

Base-Catalyzed Hydrolysis (Nucleophilic Mechanism)

In basic media (pH > 8), the reaction is driven by the direct attack of the hydroxyl anion (

).

- Nucleophilic Attack: The aggressive ion attacks the silicon atom directly.
- Inductive Acceleration: The group pulls electron density away from the silicon, making it significantly more electrophilic (partial positive charge). This results in hydrolysis rates for CMDMS that are typically faster than equivalent alkylsilanes.
- Transition State: Formation of a negatively charged pentacoordinate intermediate.
- Elimination: The methoxide ion () is displaced and subsequently protonated by water to form methanol.

Visualization of Catalytic Cycles

The following diagram illustrates the divergent pathways and the critical role of the chloromethyl group.

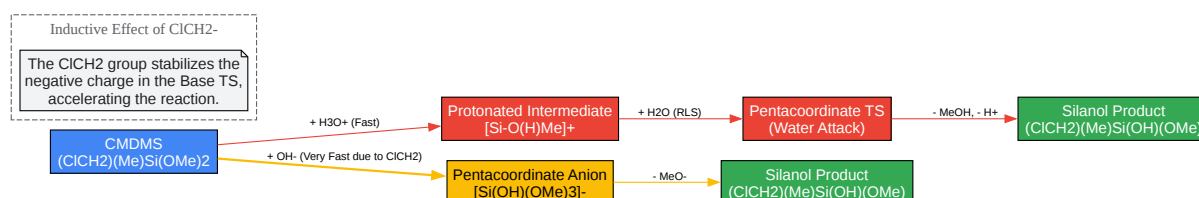

[Click to download full resolution via product page](#)

Figure 1: Comparative mechanistic pathways for CMDMS hydrolysis. Note the acceleration of the base-catalyzed path due to the electron-withdrawing chloromethyl moiety.

Kinetics & Thermodynamics

The hydrolysis of CMDMS follows pseudo-first-order kinetics when water is in excess.

Rate Constants ()

While exact constants vary by solvent/temperature, the relative reactivity sequence is:

(Under basic conditions)

The "Self-Catalysis" Phenomenon

Unlike simple alkyl silanes, the hydrolysis products of CMDMS can exhibit unique pH behavior.

- Silanol Acidity: The

group increases the acidity of the resulting silanol (

).

- Implication: As hydrolysis proceeds, the solution may become slightly more acidic, potentially auto-catalyzing further hydrolysis or condensation steps if the buffer capacity is low.

Stability of the C-Cl Bond

Critical for Drug Development: Under standard hydrolysis conditions (

), the

bond is stable. It does not hydrolyze to form a hydroxymethyl group. However, in the presence of strong nucleophiles (amines, thiols) often found in drug linkers, the

group acts as an alkylating agent.

Experimental Protocols

Protocol: Controlled Hydrolysis for Kinetic Study

Objective: Isolate the hydrolysis step from condensation to measure rates.

Reagents:

- CMDMS (Purified, >98%)
- Solvent: Deuterated Acetone () or THF-
(Avoid alcohols to prevent transesterification).
- Catalyst: 0.01 M HCl or NaOH in

Workflow:

- Preparation: Dissolve CMDMS in
to a concentration of 0.1 M.

- Initiation: Add stoichiometric equivalent of acidified/basified

(e.g.,

).

- Monitoring: Immediately transfer to NMR tube.
- Analysis: Acquire

NMR spectra every 5 minutes at 25°C.

Analytical Validation: NMR

NMR is the gold standard for validating organosilane hydrolysis.

Species	Structure	Approx. ^{[1][2][4][5][6][7][8]} [9] Chemical Shift (ppm)*
T0 (Monomer)		-5.0 to -2.0
T1 (Hydrolyzed)		-8.0 to -5.0
T2 (Fully Hydrolyzed)		-12.0 to -9.0
M (Dimer)		-15.0 to -20.0

*Note: Shifts are deshielded (more positive) compared to non-chlorinated analogs due to the electronegative Cl atom.

Experimental Workflow Diagram

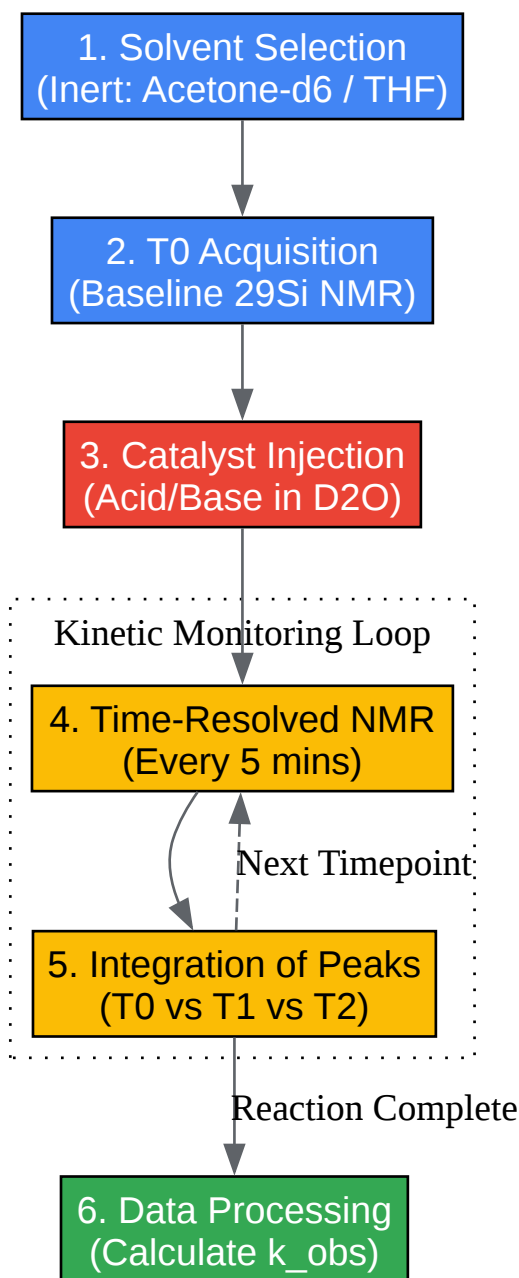

[Click to download full resolution via product page](#)

Figure 2: Step-by-step experimental workflow for kinetic characterization using NMR spectroscopy.

Safety & Handling (Drug Development Context)

Warning: CMDMS is not just a silane; it is a potential alkylating agent.

- **Toxicity:** The chloromethyl group can react with biological nucleophiles (DNA/Proteins). Handle with high-containment protocols (fume hood, double gloving).
- **HCl Generation:** Upon contact with moisture, methoxy groups hydrolyze to methanol, but if the

bond is cleaved (rare but possible under extreme stress), or if trace chlorosilanes are present, HCl gas may evolve.
- **Flammability:** Flash point is typically low. Ground all glassware.

References

- Gelest, Inc. Factors contributing to the stability of alkoxysilanes in aqueous solution. Retrieved from [6](#).
- Brinker, C. J. Hydrolysis and condensation of silicates: Effects on structure. *Journal of Non-Crystalline Solids*, 1988. Retrieved from [2](#).
- Issa, A. A., & Luyt, A. S. Kinetics of Alkoxysilanes and Organoalkoxysilanes Polymerization: A Review. *Polymers*, 2019. Retrieved from [3](#).
- ChemicalBook. Chloromethyl silane - Safety Data Sheet. Retrieved from [10](#).[\[11\]](#)
- Mane, M., et al. Optimum synthesis of (chloromethyl)silanes by chlorination and methylation reactions. *Indian Journal of Chemical Technology*, 1999. Retrieved from .

Need Custom Synthesis?

BenchChem offers custom synthesis for rare earth carbides and specific isotopic labeling.

Email: info@benchchem.com or [Request Quote Online](#).

Sources

- [1. researchgate.net](#) [[researchgate.net](#)]
- [2. brinkerlab.unm.edu](#) [[brinkerlab.unm.edu](#)]

- [3. Kinetics of Alkoxysilanes and Organoalkoxysilanes Polymerization: A Review - PMC \[pmc.ncbi.nlm.nih.gov\]](#)
- [4. researchgate.net \[researchgate.net\]](#)
- [5. researchgate.net \[researchgate.net\]](#)
- [6. gelest.com \[gelest.com\]](#)
- [7. sites.me.ucsb.edu \[sites.me.ucsb.edu\]](#)
- [8. epub.ub.uni-muenchen.de \[epub.ub.uni-muenchen.de\]](#)
- [9. publikationen.sulb.uni-saarland.de \[publikationen.sulb.uni-saarland.de\]](#)
- [10. chemicalbook.com \[chemicalbook.com\]](#)
- [11. Chloromethyl silane | 993-00-0 \[chemicalbook.com\]](#)
- [To cite this document: BenchChem. \[Technical Guide: Mechanism of Hydrolysis for Chloromethyl\(methyl\)dimethoxysilane \(CMDMS\)\]. BenchChem, \[2026\]. \[Online PDF\]. Available at: \[https://www.benchchem.com/product/b1587336/docs#technical-guide-mechanism-of-hydrolysis-for-chloromethyl-methyl-dimethoxysilane-cmdms\]](#)

Disclaimer & Data Validity:

The information provided in this document is for Research Use Only (RUO) and is strictly not intended for diagnostic or therapeutic procedures. While BenchChem strives to provide accurate protocols, we make no warranties, express or implied, regarding the fitness of this product for every specific experimental setup.

Technical Support: The protocols provided are for reference purposes. Unsure if this reagent suits your experiment?

Need Industrial/Bulk Grade? [Request Custom Synthesis Quote](#)

BenchChem

Our mission is to be the trusted global source of essential and advanced chemicals, empowering scientists and researchers to drive progress in science and industry.

Contact

Address: 3281 E Guasti Rd

Ontario, CA 91761, United States

Phone: (601) 213-4426

Email: info@benchchem.com

[Contact our Ph.D. Support Team for a compatibility check](#)