

# Comparative Guide: Ethyl Chlorodifluoroacetate (CDFA) vs. Alternative Difluoromethylating Reagents

**Author:** BenchChem Technical Support Team. **Date:** May 2026

## Compound of Interest

Compound Name: *Ethyl dichlorofluoroacetate*

CAS No.: 383-61-9

Cat. No.: B1587254

[Get Quote](#)

## Executive Summary & Critical Distinction

Target Audience: Synthetic Chemists, Process Engineers, and Drug Discovery Scientists.

Editorial Note on Reagent Identity: A critical distinction must be made regarding the subject of this guide. The prompt specified **Ethyl dichlorofluoroacetate** (EDCFA).<sup>[1][2]</sup> However, in the context of difluoromethylation (introducing a

or

group), this is chemically contradictory.

- **Ethyl dichlorofluoroacetate** (EDCFA): Contains one fluorine ( ). It is a precursor for chlorofluorocarbene ( ) and is used to synthesize chlorofluorocyclopropanes or introduce motifs.

- Ethyl chlorodifluoroacetate (CDFA): Contains two fluorines ( )  
).[3] It is a primary precursor for difluorocarbene ( )  
) and is widely used for difluoromethylation.

Assumption: This guide assumes the user intends to evaluate reagents for difluoromethylation and treats CDFA as the primary subject, while briefly contrasting it with EDCFA to ensure total technical accuracy.

## The Landscape of Difluoromethylation Reagents[4] [5]

Difluoromethylation is a pivotal transformation in medicinal chemistry, as the group acts as a lipophilic bioisostere for alcohols ( ) and thiols ( ), improving membrane permeability and metabolic stability.

### The Primary Contenders

Reagent	Chemical Structure	Active Species	Primary Mechanism	Key Application
Ethyl Chlorodifluoroacetate (CDFA)		(Carbene)	Electrophilic Carbene	Heteroatom alkylation (O-, S-, N-), Cyclopropanation
Sodium Chlorodifluoroacetate (SCDA)		(Carbene)	Electrophilic Carbene	Industrial scale Heteroatom alkylation (Solid salt of CDFA)
Zinc Difluoromethane sulfinatate (DFMS)		(Radical)	Radical (Minisci)	C-H Difluoromethylation of Heteroarenes
Ruppert-Prakash Reagent (TMS-CF <sub>2</sub> H)		(Anion)	Nucleophilic	Addition to Carbonyls (Aldehydes/Ketones)

## Deep Dive: Ethyl Chlorodifluoroacetate (CDFA)[7] Mechanism of Action

CDFA functions as a difluorocarbene (

) reservoir.[4] Under basic conditions, it undergoes hydrolysis followed by decarboxylation and chloride elimination to release the active carbene species.

Pathway:

- Hydrolysis:
- Decarboxylation:
- Elimination:

## Performance Profile

- Pros: Liquid handling (easy to pump), extremely low cost, high atom economy for carbene generation.
- Cons: Requires base activation; volatile; generates stoichiometric chloride waste.

## Comparative Analysis

### Comparison A: CDFA vs. Sodium Chlorodifluoroacetate (SCDA)

The "Liquid Ester" vs. "Solid Salt" Debate

These two reagents are mechanistically identical (both generate via decarboxylation). The choice is purely operational.

- Handling: SCDA is a stable, non-volatile solid, making it preferred for GMP manufacturing (e.g., AstraZeneca's scale-up of Roflumilast). CDFA is a liquid, which is easier for flow chemistry but poses volatility risks in batch reactors.
- Reaction Conditions: SCDA often requires higher temperatures ( ) to induce thermal decarboxylation. CDFA can be activated at lower temperatures if a strong nucleophile/base is used to cleave the ester first.
- Yields: In the difluoromethylation of phenols (O-alkylation), yields are statistically indistinguishable ( for both) when optimized.

### Comparison B: CDFA vs. Zinc Difluoromethanesulfinate (DFMS)

Electrophile vs. Radical

This is the most critical chemical distinction. You cannot swap these reagents.

- CDFA (Carbene): The species is electrophilic. It reacts best with nucleophiles (Phenols, Thiols, Amines).
  - Reaction:  
(after protonation).
- DFMS (Radical): Generates the electron-deficient radical. It reacts best with electron-deficient heterocycles via Minisci-type C-H activation.
  - Reaction:

Data Point: Attempting to use CDFA to difluoromethylate a pyridine ring (C-H activation) will fail (0% yield). Attempting to use DFMS to alkylate a phenol (O-H) will result in poor selectivity and side reactions.

## Decision Matrix & Mechanism Visualization

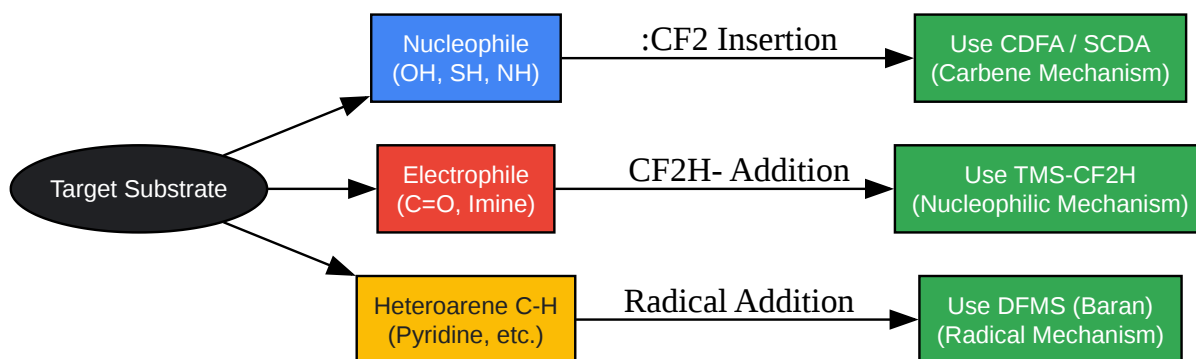

[Click to download full resolution via product page](#)

Caption: Reagent selection logic based on substrate electronic properties.

## Experimental Protocols

## Protocol 1: O-Difluoromethylation of Phenols using CDFA

Objective: Synthesis of Aryl Difluoromethyl Ethers (

).

Mechanism: Base-mediated carbene generation and insertion.

- Setup: Charge a round-bottom flask with Phenol (1.0 equiv) and (1.5 equiv) in DMF (0.5 M).
- Reagent Addition: Add Ethyl Chlorodifluoroacetate (CDFA) (2.0 equiv) dropwise at room temperature.
- Reaction: Heat the mixture to 70–80°C for 4–6 hours. Note: Vigorous bubbling ( ) will occur.
- Workup: Cool to RT. Dilute with water and extract with Ethyl Acetate. Wash organics with brine to remove DMF.
- Validation: Monitor disappearance of Phenol by TLC. Product formation confirmed by NMR (doublet around -82 ppm).

## Protocol 2: C-H Difluoromethylation using DFMS (Contrast)

Objective: Functionalization of Heteroarenes. Mechanism: Radical Minisci Reaction.

- Setup: Dissolve Heteroarene (1.0 equiv) and DFMS (3.0 equiv) in DCM/Water (biphasic 1:1).
- Oxidant: Add TBHP (tert-butyl hydroperoxide) (5.0 equiv) slowly at 0°C.
- Reaction: Stir vigorously at RT for 12–24 hours.
- Note: This reaction requires no metal catalyst but relies on the oxidative generation of the radical species from the sulfinate.

## Summary Table: Yield & Selectivity

Substrate Class	CDFA Yield	DFMS Yield	Preferred Reagent
Phenols ( )	85-95%	<10%	CDFA / SCDA
Thiols ( )	90-98%	<5%	CDFA / SCDA
Pyridines (C-H)	0%	50-70%	DFMS
Aldehydes ( )	0%	<5%	TMS-CF <sub>2</sub> H

## References

- Hu, J., Zhang, W., & Wang, F. (2009). "Difluoromethyl 2-pyridyl sulfone: A new gem-difluoroolefination reagent." *Chemical Communications*.<sup>[5]</sup> [Link](#)
- Fier, P. S., & Hartwig, J. F. (2012). "Copper-mediated difluoromethylation of aryl iodides." *Journal of the American Chemical Society*. [Link](#)
- Fujiwara, Y., et al. (2012). "Practical C–H functionalization of quinolines with difluoromethyl radicals." *Nature*. [Link](#)
- Sperry, J. B., et al. (2012).<sup>[6]</sup> "A Robust Process for an mGluR5 Negative Allosteric Modulator: Difluoromethylation and Sonogashira Coupling on Large Scale." *Organic Process Research & Development*. [Link](#)
- Zhu, Z., et al. (2025).<sup>[7]</sup> "Access to 2,2-Halofluorobicyclo[1.1.1] Pentanes via Non Ozone-Depleting Ethyl Dihalofluoroacetate." *Advanced Synthesis & Catalysis*. [Link](#)

### Need Custom Synthesis?

BenchChem offers custom synthesis for rare earth carbides and specific isotopic labeling.

Email: [info@benchchem.com](mailto:info@benchchem.com) or [Request Quote Online](#).

## Sources

- [1. researchgate.net \[researchgate.net\]](#)
- [2. researchgate.net \[researchgate.net\]](#)
- [3. sioc.ac.cn \[sioc.ac.cn\]](#)
- [4. Chlorodifluoroacetamide | 354-28-9 | Benchchem \[benchchem.com\]](#)
- [5. pubs.acs.org \[pubs.acs.org\]](#)
- [6. Organic Syntheses Procedure \[orgsyn.org\]](#)
- [7. BJOC - Copper-promoted C5-selective bromination of 8-aminoquinoline amides with alkyl bromides \[beilstein-journals.org\]](#)
- To cite this document: BenchChem. [Comparative Guide: Ethyl Chlorodifluoroacetate (CDFA) vs. Alternative Difluoromethylating Reagents]. BenchChem, [2026]. [Online PDF]. Available at: [<https://www.benchchem.com/product/b1587254/docs#comparative-guide-ethyl-chlorodifluoroacetate-cdfa-vs-alternative-difluoromethylating-reagents>]

---

### Disclaimer & Data Validity:

The information provided in this document is for Research Use Only (RUO) and is strictly not intended for diagnostic or therapeutic procedures. While BenchChem strives to provide accurate protocols, we make no warranties, express or implied, regarding the fitness of this product for every specific experimental setup.

**Technical Support:** The protocols provided are for reference purposes. Unsure if this reagent suits your experiment?

**Need Industrial/Bulk Grade?** [Request Custom Synthesis Quote](#)

# BenchChem

Our mission is to be the trusted global source of essential and advanced chemicals, empowering scientists and researchers to drive progress in science and industry.

## Contact

Address: 3281 E Guasti Rd

Ontario, CA 91761, United States

Phone: (601) 213-4426

Email: [info@benchchem.com](mailto:info@benchchem.com)

[Contact our Ph.D. Support Team for a compatibility check](#)