

# 3-(4-Chlorophenylthio)Butyric Acid structure elucidation

**Author:** BenchChem Technical Support Team. **Date:** May 2026

## Compound of Interest

Compound Name: 3-(4-Chlorophenylthio)Butyric Acid

CAS No.: 90919-34-9

Cat. No.: B1587244

[Get Quote](#)

An In-depth Technical Guide to the Structure Elucidation of **3-(4-Chlorophenylthio)Butyric Acid**

## Abstract

The definitive assignment of a chemical structure is a foundational requirement in chemical research and drug development. It ensures reproducibility, informs understanding of structure-activity relationships (SAR), and is a prerequisite for regulatory submission. This technical guide provides a comprehensive, methodology-driven walkthrough for the complete structure elucidation of **3-(4-Chlorophenylthio)Butyric Acid**. We will employ a multi-spectroscopic approach, integrating data from Mass Spectrometry (MS), Infrared (IR) Spectroscopy, and a suite of one- and two-dimensional Nuclear Magnetic Resonance (NMR) experiments. The narrative is designed for researchers, scientists, and drug development professionals, emphasizing not just the procedural steps but the strategic logic and causal reasoning behind each experimental choice, thereby creating a self-validating analytical workflow.

## The Elucidation Strategy: A Multi-Pronged Approach

The structure of an unknown compound is a puzzle. Relying on a single analytical technique is fraught with ambiguity. A robust elucidation strategy, therefore, employs several orthogonal techniques, each providing a unique piece of structural information. The data from these techniques are then synergistically assembled to build an unambiguous molecular structure.

Our strategy for elucidating the structure of **3-(4-Chlorophenylthio)Butyric Acid** follows a logical progression:

- **Determine the Molecular Formula:** High-Resolution Mass Spectrometry (HRMS) provides the accurate mass, from which the elemental composition is derived. This is the cornerstone of the entire process.
- **Identify Functional Groups:** Fourier-Transform Infrared (FT-IR) Spectroscopy offers a rapid and definitive way to identify key chemical bonds and functional groups present, such as the carboxylic acid.
- **Map the Carbon-Hydrogen Framework:**  $^1\text{H}$  and  $^{13}\text{C}$  Nuclear Magnetic Resonance (NMR) spectroscopy maps the proton and carbon environments within the molecule.
- **Establish Connectivity:** Two-dimensional (2D) NMR experiments (COSY, HSQC, HMBC) are the final and most powerful step, allowing us to connect the individual atoms and fragments into the final, complete structure.

The following workflow diagram illustrates this strategic approach.

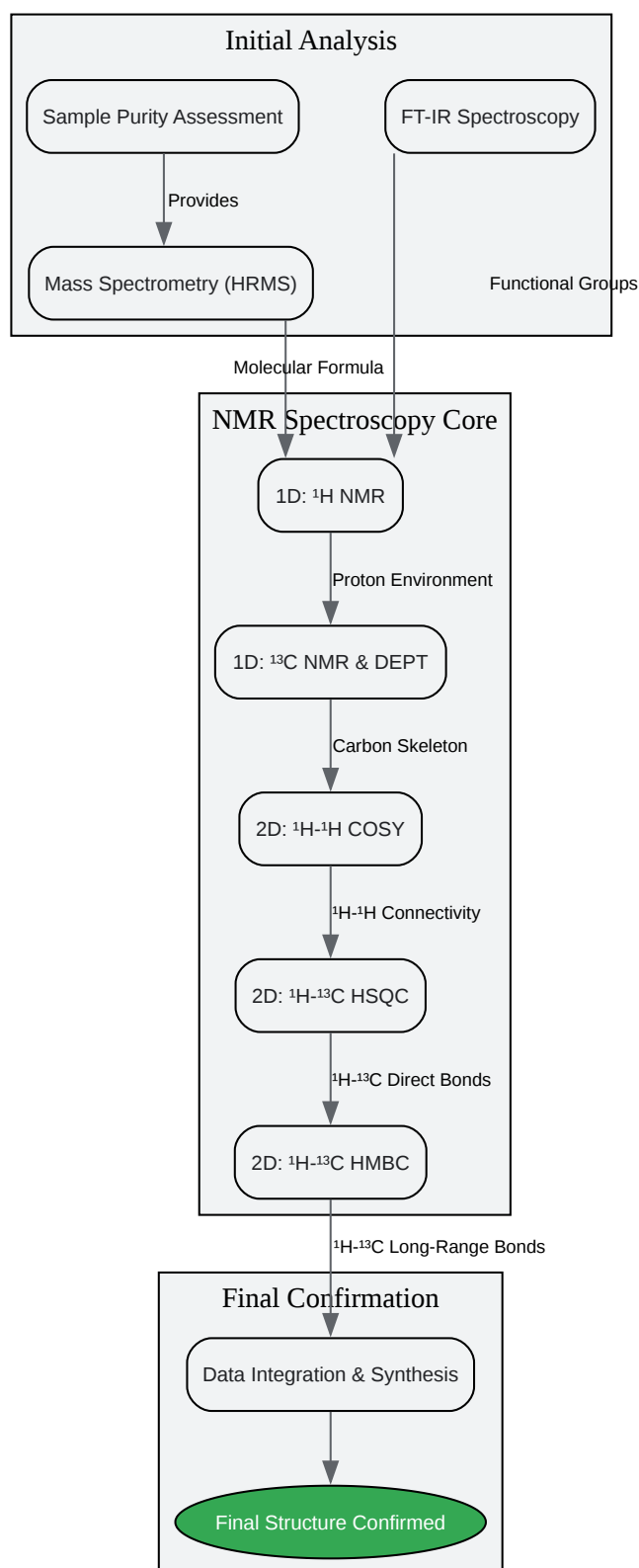

[Click to download full resolution via product page](#)

Caption: Overall workflow for the structure elucidation of **3-(4-Chlorophenylthio)Butyric Acid**.

# Foundational Analysis: Molecular Formula and Functional Groups

Before delving into complex NMR analysis, we must establish the elemental composition and the primary functional groups. This foundational data provides critical constraints that guide the interpretation of subsequent, more detailed spectra.

## Mass Spectrometry: Defining the Molecular Formula

High-Resolution Mass Spectrometry (HRMS) is the definitive technique for determining a compound's elemental composition. By measuring the mass-to-charge ratio ( $m/z$ ) to a high degree of precision (typically  $<5$  ppm), we can distinguish between isobaric formulas.

For **3-(4-Chlorophenylthio)Butyric Acid**, the molecular formula is predicted to be  $C_{10}H_{11}ClO_2S$ . A key validation is the characteristic isotopic pattern of chlorine: the presence of two major isotopes,  $^{35}Cl$  and  $^{37}Cl$ , in an approximate 3:1 ratio results in two molecular ion peaks ( $[M]^+$  and  $[M+2]^+$ ) separated by two mass units, with a relative intensity of  $\sim 3:1$ .

Table 1: Predicted HRMS Data for  $C_{10}H_{11}ClO_2S$

Ion	Calculated Exact Mass	Observed $m/z$	Mass Error (ppm)	Relative Abundance
$[M]^+$ (using $^{35}Cl$ )	230.01697	230.0171	0.56	100%

|  $[M+2]^+$  (using  $^{37}Cl$ ) | 232.01402 | 232.0142 | 0.77 |  $\sim 32\%$  |

Furthermore, the fragmentation pattern in the mass spectrum provides initial structural clues. Key expected fragments include the loss of the carboxyl group and cleavages around the sulfur atom.<sup>[1][2]</sup>

## Experimental Protocol: HRMS Analysis

- Sample Preparation: Dissolve  $\sim 0.1$  mg of the compound in 1 mL of a suitable solvent (e.g., methanol or acetonitrile).

- Instrumentation: Utilize an Electrospray Ionization Time-of-Flight (ESI-TOF) or Orbitrap mass spectrometer.
- Ionization Mode: Run in both positive and negative ion modes to ensure detection. For a carboxylic acid, negative mode ( $[M-H]^-$ ) is often highly sensitive.
- Data Acquisition: Acquire data over a mass range of  $m/z$  50-500. Ensure the instrument is calibrated with a known standard immediately prior to the run to guarantee mass accuracy.
- Analysis: Process the data to identify the molecular ion peaks. Use the instrument software to calculate the elemental composition based on the accurate mass and compare it with the observed isotopic pattern.

## Infrared Spectroscopy: A Functional Group Fingerprint

FT-IR spectroscopy provides a rapid confirmation of the functional groups suggested by the molecular formula. The spectrum is a plot of infrared light absorption versus wavenumber, and specific bonds vibrate at characteristic frequencies.[3] For our target molecule, the most telling absorptions are those associated with the carboxylic acid moiety.

Table 2: Characteristic IR Absorption Bands for **3-(4-Chlorophenylthio)Butyric Acid**

Wavenumber (cm <sup>-1</sup> )	Bond	Vibration Type	Appearance
<b>2500-3300</b>	<b>O-H</b>	<b>Stretching</b>	<b>Very broad, strong</b>
~2970	C-H (alkyl)	Stretching	Medium
~1710	C=O	Stretching	Strong, sharp
~1600, ~1475	C=C (aromatic)	Stretching	Medium to weak
~1430	C-S	Stretching	Weak, in fingerprint region

| ~820 | C-H (p-subst. aromatic) | Out-of-plane bend | Strong |

The extremely broad O-H stretch is a hallmark of a hydrogen-bonded carboxylic acid.[4] The strong carbonyl (C=O) absorption at  $\sim 1710\text{ cm}^{-1}$  further confirms this group.

## Experimental Protocol: FT-IR Spectroscopy

- **Sample Preparation:** If the sample is a solid, create a KBr pellet by grinding a small amount of the sample with dry potassium bromide and pressing it into a transparent disk. If it is an oil, a thin film can be prepared between two salt (NaCl or KBr) plates.
- **Background Scan:** Run a background spectrum of the empty sample compartment (or the KBr pellet/salt plates) to subtract atmospheric and instrumental absorptions.
- **Sample Scan:** Place the sample in the instrument and acquire the spectrum. Typically, 16-32 scans are co-added to improve the signal-to-noise ratio.
- **Data Analysis:** Process the spectrum to identify the wavenumbers of major absorption peaks and compare them to correlation tables to assign functional groups.

## NMR Spectroscopy: Assembling the Molecular Framework

NMR is the most powerful technique for determining the precise structure of an organic molecule in solution. By mapping the carbon-hydrogen framework and establishing through-bond connectivities, it allows for the unambiguous assembly of the molecular puzzle. A combination of 1D ( $^1\text{H}$ ,  $^{13}\text{C}$ , DEPT) and 2D (COSY, HSQC, HMBC) experiments is required for a complete assignment.[5][6][7]

### $^1\text{H}$ NMR: The Proton Environment

The  $^1\text{H}$  NMR spectrum provides information on the number of distinct proton environments, their electronic surroundings (chemical shift), the number of protons in each environment (integration), and the number of neighboring protons (multiplicity/splitting).

Table 3: Predicted  $^1\text{H}$  NMR Data (500 MHz,  $\text{CDCl}_3$ )

Label	Chemical Shift ( $\delta$ , ppm)	Multiplicity	Integration	Assignment
H-a	~11.5	br s	1H	-COOH
H-b/b'	~7.35	d	2H	Aromatic H (ortho to S)
H-c/c'	~7.28	d	2H	Aromatic H (ortho to Cl)
H-d	~3.75	m	1H	-S-CH-
H-e	~2.70	m	2H	-CH <sub>2</sub> -COOH

| H-f | ~1.40 | d | 3H | -CH(CH<sub>3</sub>) |

- Causality: The aromatic protons appear as two distinct doublets, characteristic of a 1,4- (para) disubstituted benzene ring. The proton at position 'd' is deshielded by the adjacent electronegative sulfur atom, shifting it downfield. The methyl group 'f' is a doublet because it is coupled to the single proton at 'd'. The methylene protons 'e' are diastereotopic due to the adjacent chiral center at 'd' and will likely appear as a complex multiplet.

## <sup>13</sup>C NMR and DEPT: The Carbon Skeleton

The <sup>13</sup>C NMR spectrum reveals the number of unique carbon environments. The DEPT-135 experiment is particularly useful, showing CH and CH<sub>3</sub> signals as positive peaks and CH<sub>2</sub> signals as negative peaks. Quaternary carbons (including C=O and substituted aromatic carbons) are absent in DEPT spectra.

Table 4: Predicted <sup>13</sup>C NMR Data (125 MHz, CDCl<sub>3</sub>)

Chemical Shift ( $\delta$ , ppm)	DEPT-135	Assignment
<b>~178.0</b>	<b>Absent</b>	<b>C=O (Carboxylic Acid)</b>
~134.5	Absent	Aromatic C-S
~133.2	Absent	Aromatic C-Cl
~132.1	Positive	Aromatic CH
~129.5	Positive	Aromatic CH
~47.5	Positive	-S-CH-
~41.0	Negative	-CH <sub>2</sub> -COOH

| ~21.5 | Positive | -CH<sub>3</sub> |

## 2D NMR: Establishing Connectivity

While 1D NMR identifies the pieces, 2D NMR shows how they are connected.

- <sup>1</sup>H-<sup>1</sup>H COSY (Correlation Spectroscopy): This experiment identifies protons that are coupled to each other (typically separated by 2 or 3 bonds). For our molecule, the key correlation will be within the butyric acid chain.

Caption: Key <sup>3</sup>J (three-bond) correlations expected in the <sup>1</sup>H-<sup>1</sup>H COSY spectrum.

- <sup>1</sup>H-<sup>13</sup>C HSQC (Heteronuclear Single Quantum Coherence): This experiment maps each proton directly to the carbon it is attached to (a one-bond correlation). This allows for the definitive assignment of the carbon signals based on the more easily assigned proton spectrum.
- <sup>1</sup>H-<sup>13</sup>C HMBC (Heteronuclear Multiple Bond Correlation): This is arguably the most critical experiment for confirming the overall structure. It reveals correlations between protons and carbons that are 2 or 3 bonds away. This allows us to connect the different spin systems.

Key Expected HMBC Correlations:

- Connecting the Butyric Acid Chain: Protons H-e (-CH<sub>2</sub>-) will show a correlation to the carboxyl carbon (C=O).
- Connecting the Chain to Sulfur/Aryl Group: Proton H-d (-S-CH-) will show a correlation to the aromatic carbon attached to sulfur (C-S).
- Confirming the Aryl Substitution: Aromatic protons H-b will show correlations to the C-S and C-Cl carbons, confirming their positions.

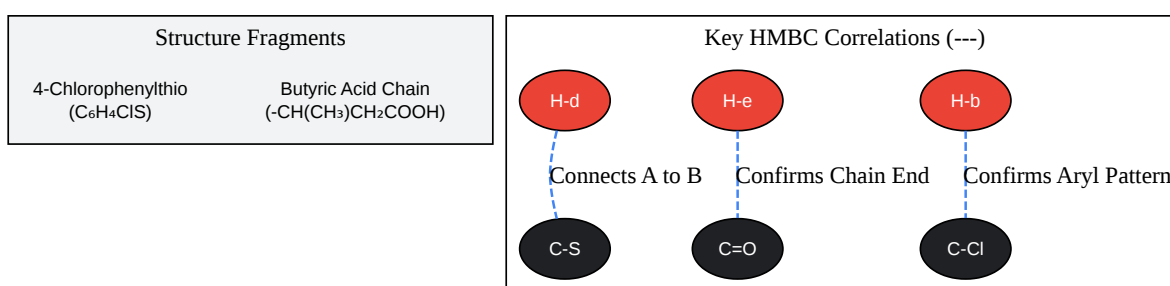

[Click to download full resolution via product page](#)

Caption: Logical connections established by key long-range HMBC correlations.

## Experimental Protocol: NMR Spectroscopy

- Sample Preparation: Dissolve 5-10 mg of the sample in ~0.6 mL of a deuterated solvent (e.g., CDCl<sub>3</sub>) in a 5 mm NMR tube. Add a small amount of tetramethylsilane (TMS) as an internal reference ( $\delta$  0.00 ppm), although modern spectrometers can reference the residual solvent peak.[8]
- Instrumentation: Use a high-field NMR spectrometer (e.g., 400 MHz or higher) for better signal dispersion.[6]
- 1D Spectra Acquisition:
  - Acquire a standard <sup>1</sup>H spectrum.

- Acquire a proton-decoupled  $^{13}\text{C}$  spectrum.
- Acquire DEPT-135 and DEPT-90 spectra.
- 2D Spectra Acquisition: Acquire standard COSY, HSQC, and HMBC experiments using the instrument's predefined parameter sets. Ensure sufficient scans are acquired for good signal-to-noise, especially for the less sensitive HMBC experiment.
- Data Processing & Analysis: Process all spectra using appropriate software (e.g., MestReNova, TopSpin). Phase and baseline correct the spectra. Integrate  $^1\text{H}$  signals. Pick peaks for all spectra and use the 2D data to build connectivity tables and confirm the final structure.

## Final Synthesis and Structure Confirmation

The final step is to integrate all the data into a single, cohesive conclusion.

- HRMS established the molecular formula as  $\text{C}_{10}\text{H}_{11}\text{ClO}_2\text{S}$ .
- FT-IR confirmed the presence of a carboxylic acid functional group and an aromatic ring.
- $^1\text{H}$  and  $^{13}\text{C}$  NMR identified all unique proton and carbon environments, consistent with the proposed structure.
- COSY confirmed the proton-proton connectivity of the  $-\text{CH}(\text{CH}_3)\text{CH}_2-$  fragment.
- HSQC unambiguously assigned each protonated carbon.
- HMBC provided the crucial long-range correlations that connected the 4-chlorophenyl group to the sulfur, the sulfur to the 3-position of the butyric acid chain, and confirmed the position of the carboxyl group.

All collected data are internally consistent and point unequivocally to the structure being **3-(4-Chlorophenylthio)Butyric Acid**.

## Conclusion

The structure elucidation of a novel compound is a systematic process of evidence gathering and logical deduction. Through the strategic application of mass spectrometry, infrared spectroscopy, and a full suite of 1D and 2D NMR experiments, we have confidently determined the chemical structure of **3-(4-Chlorophenylthio)Butyric Acid**. This guide has demonstrated not only the requisite experimental protocols but also the critical importance of understanding the causality behind each analytical step. This robust, self-validating methodology ensures the scientific integrity required for advanced research and development in the chemical and pharmaceutical sciences.

## References

- Doc Brown's Chemistry. (n.d.). Mass spectrum of butanoic acid. Retrieved January 21, 2026, from [\[Link\]](#)
- MassBank. (2008). BUTYRIC ACID; EI-B; MS. MassBank of North America (MoNA). Retrieved January 21, 2026, from [\[Link\]](#)
- Ashenhurst, J. (2015). Thiols And Thioethers. Master Organic Chemistry. Retrieved January 21, 2026, from [\[Link\]](#)
- Stanciu, I. (2024). FTIR Spectroscopy Analysis of Butanoic Acid. Journal of Applied Chemical Science International, 15(2), 26-29. Retrieved January 21, 2026, from [\[Link\]](#)
- National Center for Biotechnology Information. (n.d.). 3-(4-Chlorophenyl)-4-hydroxybutyric acid. PubChem Compound Database. Retrieved January 21, 2026, from [\[Link\]](#)
- Chemistry Learner. (n.d.). Thioether: Structure, Formula, Synthesis, and Examples. Retrieved January 21, 2026, from [\[Link\]](#)
- National Institute of Standards and Technology. (n.d.). Butyric Acid, TMS derivative. NIST Chemistry WebBook. Retrieved January 21, 2026, from [\[Link\]](#)
- Karrouchi, K., et al. (2018). Thioethers: An Overview. Journal of Chemical and Pharmaceutical Research, 10(4), 1-10. Retrieved January 21, 2026, from [\[Link\]](#)
- Biological Magnetic Resonance Bank. (n.d.). bmse000402 Butyric Acid. Retrieved January 21, 2026, from [\[Link\]](#)

- LibreTexts Chemistry. (2020). 15.12: Thioethers (Sulfides) and Silyl Ethers. Retrieved January 21, 2026, from [\[Link\]](#)
- Nikolova, P., et al. (2021). A Complete  $^1\text{H}$  and  $^{13}\text{C}$  NMR Data Assignment for Three 3-[Substituted methylidene]-1H,3H-naphtho-[1,8-cd]-pyran-1-ones. *Magnetochemistry*, 7(9), 125. Retrieved January 21, 2026, from [\[Link\]](#)
- Doc Brown's Chemistry. (n.d.). Infrared spectrum of butanoic acid. Retrieved January 21, 2026, from [\[Link\]](#)
- Doc Brown's Chemistry. (n.d.).  $^{13}\text{C}$  nmr spectrum of butanoic acid. Retrieved January 21, 2026, from [\[Link\]](#)
- de Oliveira, A. A., et al. (2023). The Challenging Complete and Detailed  $^1\text{H}$  and  $^{13}\text{C}$  NMR Assignment for ent-Kaurenoic Acid, a Remarkable Natural Product. *Molecules*, 28(23), 7793. Retrieved January 21, 2026, from [\[Link\]](#)
- Illinois State University, Department of Chemistry. (2015). Infrared Spectroscopy. Retrieved January 21, 2026, from [\[Link\]](#)
- University of Calgary, Department of Chemistry. (n.d.). Ch13 - Sample IR spectra. Retrieved January 21, 2026, from [\[Link\]](#)

### Need Custom Synthesis?

BenchChem offers custom synthesis for rare earth carbides and specific isotopic labeling.

Email: [info@benchchem.com](mailto:info@benchchem.com) or [Request Quote Online](#).

## Sources

- [1. mass spectrum of butanoic acid C<sub>4</sub>H<sub>8</sub>O<sub>2</sub> CH<sub>3</sub>CH<sub>2</sub>CH<sub>2</sub>COOH fragmentation pattern of m/z m/e ions for analysis and identification of butyric acid image diagram doc brown's advanced organic chemistry revision notes \[docbrown.info\]](#)
- [2. massbank.eu \[massbank.eu\]](#)
- [3. infrared spectrum of butanoic acid C<sub>4</sub>H<sub>8</sub>O<sub>2</sub> CH<sub>3</sub>CH<sub>2</sub>CH<sub>2</sub>COOH prominent wavenumbers cm<sup>-1</sup> detecting ? functional groups present finger print for identification of butyric acid image](#)

[diagram doc brown's advanced organic chemistry revision notes \[docbrown.info\]](#)

- [4. researchgate.net \[researchgate.net\]](#)
- [5. A Complete <sup>1</sup>H and <sup>13</sup>C NMR Data Assignment for Three 3-\[Substituted methylidene\]-1H,3H-naphtho-\[1,8-cd\]-pyran-1-ones \[mdpi.com\]](#)
- [6. preprints.org \[preprints.org\]](#)
- [7. The Challenging Complete and Detailed <sup>1</sup>H and <sup>13</sup>C NMR Assignment for ent-Kaurenoic Acid, a Remarkable Natural Product - PMC \[pmc.ncbi.nlm.nih.gov\]](#)
- [8. <sup>13</sup>C nmr spectrum of butanoic acid C<sub>4</sub>H<sub>8</sub>O<sub>2</sub> CH<sub>3</sub>CH<sub>2</sub>CH<sub>2</sub>COOH analysis of chemical shifts ppm interpretation of C-13 chemical shifts ppm of butyric acid C<sub>13</sub> <sup>13</sup>C nmr doc brown's advanced organic chemistry revision notes \[docbrown.info\]](#)
- To cite this document: BenchChem. [3-(4-Chlorophenylthio)Butyric Acid structure elucidation]. BenchChem, [2026]. [Online PDF]. Available at: [\[https://www.benchchem.com/product/b1587244/docs#3-4-chlorophenylthio-butyric-acid-structure-elucidation\]](https://www.benchchem.com/product/b1587244/docs#3-4-chlorophenylthio-butyric-acid-structure-elucidation)

---

#### Disclaimer & Data Validity:

The information provided in this document is for Research Use Only (RUO) and is strictly not intended for diagnostic or therapeutic procedures. While BenchChem strives to provide accurate protocols, we make no warranties, express or implied, regarding the fitness of this product for every specific experimental setup.

**Technical Support:** The protocols provided are for reference purposes. Unsure if this reagent suits your experiment?

**Need Industrial/Bulk Grade?** [Request Custom Synthesis Quote](#)

## BenchChem

Our mission is to be the trusted global source of essential and advanced chemicals, empowering scientists and researchers to drive progress in science and industry.

#### Contact

Address: 3281 E Guasti Rd

Ontario, CA 91761, United States

Phone: (601) 213-4426

Email: [info@benchchem.com](mailto:info@benchchem.com)

Contact our Ph.D. Support Team for a compatibility check