

Application Note: Controlled Release of Biomolecules using 5-Methyl-2-nitrobenzyl Chloride

Author: BenchChem Technical Support Team. **Date:** May 2026

Compound of Interest

Compound Name: *5-Methyl-2-nitrobenzyl chloride*

CAS No.: 66424-91-7

Cat. No.: B1586813

[Get Quote](#)

Abstract

The precise spatiotemporal control of bioactive molecules is a cornerstone of modern chemical biology. This guide details the utilization of **5-Methyl-2-nitrobenzyl chloride** as a photolabile protecting group (PPG). Unlike the widely used 4,5-dimethoxy variants, the 5-methyl derivative offers a balance of structural compactness and reliable Norrish Type II photocleavage kinetics. This document provides a validated workflow for "caging" acidic and nucleophilic biomolecules (e.g., carboxylates, phosphates, amines) and a standardized protocol for their UV-mediated release ("uncaging").

Scientific Mechanism & Rationale

The Ortho-Nitrobenzyl Effect

The utility of **5-Methyl-2-nitrobenzyl chloride** stems from the photochemistry of the ortho-nitrobenzyl moiety. Upon irradiation with near-UV light (typically 300–365 nm), the molecule undergoes an intramolecular rearrangement known as the Norrish Type II reaction.

Mechanism Breakdown:

- **Excitation:** The ground state nitro group absorbs a photon (), entering an excited singlet state, which rapidly crosses to a triplet state.
- **Hydrogen Abstraction:** The excited nitro oxygen abstracts a hydrogen atom from the benzylic carbon (or the -carbon in -substituted variants).
- **aci-Nitro Intermediate:** This forms a transient aci-nitro species.^[1]
- **Rearrangement & Cleavage:** The aci-nitro tautomer rearranges to a cyclic hemiacetal (or similar intermediate), which collapses to release the free biomolecule and a nitroso-benzaldehyde byproduct.

Why 5-Methyl-2-nitrobenzyl?

While 4,5-dimethoxy-2-nitrobenzyl (DMNB) groups are popular for their red-shifted absorption, the 5-methyl-2-nitrobenzyl scaffold offers specific advantages in synthetic handling:

- **Steric Profile:** The 5-methyl group is meta to the nitro group and para to the benzylic center. It provides a slight electron-donating effect without the steric bulk of dimethoxy groups at the 4,5 positions, potentially improving solubility in certain organic synthesis steps.
- **Atom Economy:** Lower molecular weight compared to DMNB, offering higher loading capacities in solid-phase applications.

Pathway Visualization

The following diagram illustrates the photochemical uncaging pathway.

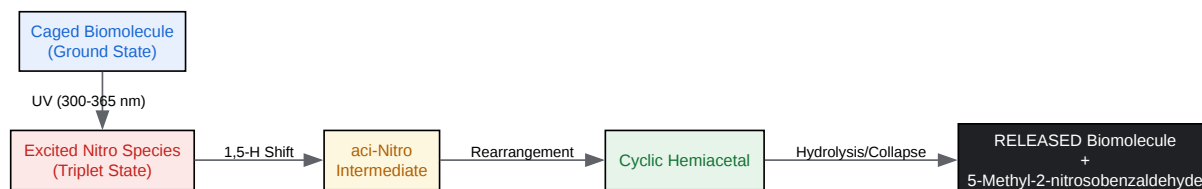

[Click to download full resolution via product page](#)

Figure 1: The Norrish Type II photocleavage mechanism for 5-methyl-2-nitrobenzyl caged compounds.

Experimental Protocols

Protocol A: Chemical Synthesis (Caging)

Objective: To synthesize a caged carboxylate (e.g., Caged-Glutamate or Caged-Drug) using **5-Methyl-2-nitrobenzyl chloride**.

Reagents:

- Target Biomolecule (containing -COOH, -OH, or -NH).[2]
- **5-Methyl-2-nitrobenzyl chloride** (1.1 - 1.5 equivalents).
- Base: Potassium Carbonate () or Cesium Carbonate () for acids; DIPEA for amines.
- Solvent: Anhydrous DMF or Acetone.
- Catalyst: Sodium Iodide (NaI) (Optional, Finkelstein condition to generate reactive iodide in situ).

Step-by-Step Procedure:

- Preparation: Dissolve the Target Biomolecule (1.0 mmol) in anhydrous DMF (5 mL) under an inert atmosphere (N₂ or Ar).
- Activation: Add NaH (1.5 mmol). Stir for 15 minutes at room temperature to deprotonate the carboxylic acid.
- Alkylation: Add **5-Methyl-2-nitrobenzyl chloride** (1.2 mmol) dropwise.
 - Tip: If the chloride is sluggish, add 10 mol% NaI to catalyze the reaction via the transient iodide.
- Reaction: Stir at room temperature for 4–12 hours. Monitor by TLC (or LC-MS) for the disappearance of the starting material.
- Quench & Extraction: Dilute with EtOAc (50 mL) and wash with water (3 x 20 mL) and brine (1 x 20 mL) to remove DMF.
- Purification: Dry the organic layer over Na₂SO₄, filter, and concentrate. Purify via Flash Column Chromatography (typically Hexane:EtOAc gradients).
- Validation: Confirm structure via ¹H-NMR (look for benzylic protons ~5.5 ppm) and Mass Spectrometry.

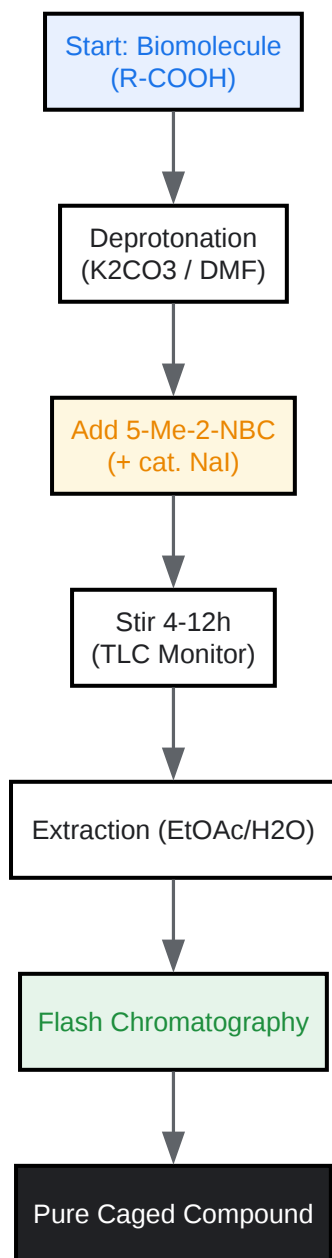

[Click to download full resolution via product page](#)

Figure 2: Synthetic workflow for caging a carboxylic acid.

Protocol B: Photolysis (Uncaging)

Objective: Controlled release of the active biomolecule in solution.

Equipment:

- UV Light Source: 365 nm LED (recommended) or Mercury Arc Lamp with 300–400 nm bandpass filter.
- Quartz cuvette (glass absorbs UV).

Procedure:

- Sample Prep: Dissolve the caged compound in a suitable buffer (e.g., PBS pH 7.4) containing a small amount of DMSO if solubility is limiting. Final concentration: 10–100 .
- Irradiation: Place the cuvette 5–10 cm from the light source. Irradiate for defined intervals (e.g., 0, 30s, 1min, 5min).
 - Note: The quantum yield () for nitrobenzyl groups is typically 0.01 – 0.1.
- Quantification: Analyze aliquots by HPLC.
 - Peak A: Disappearance of Caged Compound.
 - Peak B: Appearance of Free Biomolecule.
 - Peak C: Appearance of Nitroso-benzaldehyde byproduct (often absorbs at ~350 nm).

Data Analysis & Comparison

The following table compares **5-Methyl-2-nitrobenzyl chloride** with other common caging reagents to aid in experimental design.

Feature	2-Nitrobenzyl (Standard)	5-Methyl-2-nitrobenzyl	4,5-Dimethoxy-2-nitrobenzyl (DMNB)
Excitation	~260 nm (tail to 320 nm)	~270 nm (tail to 340 nm)	~350 nm
Uncaging	< 320 nm (UV-B/C risk)	300–365 nm (Near UV)	365–405 nm
Solubility	Moderate	Improved (Lipophilic)	Moderate
Byproduct	2-Nitrosobenzaldehyde	5-Methyl-2-nitrosobenzaldehyde	4,5-Dimethoxy-2-nitrosobenzaldehyde
Byproduct Toxicity	High (reactive aldehyde)	High (reactive aldehyde)	High (reactive aldehyde)

Technical Note: If byproduct toxicity is a concern for your specific cell line, consider using

-methyl variants (e.g., 1-(2-nitrophenyl)ethyl chloride), which release a ketone instead of an aldehyde [1]. However, for solid-phase synthesis or non-cellular assays, the **5-methyl-2-nitrobenzyl chloride** described here is highly effective.

Troubleshooting & Optimization

- Issue: Low Yield in Synthesis.
 - Cause: Steric hindrance or poor nucleophilicity.
 - Solution: Switch to Cesium Carbonate () in DMF (Cesium effect) or add NaI catalyst. Ensure the reagent is fresh; benzyl chlorides can hydrolyze if stored improperly.
- Issue: Slow Photolysis.
 - Cause: Inner filter effect (high concentration absorbing light) or incorrect wavelength.
 - Solution: Dilute the sample (OD < 0.5 at excitation wavelength). Ensure your light source emits sufficient power at 300–365 nm.

- Issue: Precipitation during Photolysis.
 - Cause: The nitroso byproduct is often insoluble in water.
 - Solution: Include 1–5% DMSO or cyclodextrin in the buffer to solubilize the byproduct.

Safety & Handling

- Reagent: **5-Methyl-2-nitrobenzyl chloride** is an alkylating agent. It is a lachrymator and skin irritant. Handle in a fume hood with gloves and eye protection.
- UV Light: Wear UV-protective eyewear when operating the photolysis setup.
- Storage: Store the reagent at 4°C, protected from light and moisture.

References

- Kaplan, J. H., Forbush, B., & Hoffman, J. F. (1978). Rapid photolytic release of adenosine 5'-triphosphate from a protected analogue: utilization by the Na:K pump of human red blood cell ghosts. *Biochemistry*, 17(10), 1929–1935. [Link](#)
- Klán, P., et al. (2013). Photoremovable Protecting Groups in Chemistry and Biology: Reaction Mechanisms and Efficacy. *Chemical Reviews*, 113(1), 119–191. [Link](#)
- Corrie, J. E. T., et al. (2005). Photoremovable Protecting Groups Used for the Caging of Biomolecules.[3][4][5] In *Dynamic Studies in Biology* (pp. 1-28). Wiley-VCH.[4] [Link](#)
- Schaper, K., et al. (2002). Synthesis and photochemical properties of alpha,4-dicarboxy-2-nitrobenzyl caged compounds. *European Journal of Organic Chemistry*, 2002(6), 1037–1046. (Context on ring substitution effects). [Link](#)

Need Custom Synthesis?

BenchChem offers custom synthesis for rare earth carbides and specific isotopic labeling.

Email: info@benchchem.com or [Request Quote Online](#).

Sources

- [1. pubs.acs.org \[pubs.acs.org\]](https://pubs.acs.org)
- [2. Reverse Engineering Caged Compounds: Design Principles for their Application in Biology - PMC \[pmc.ncbi.nlm.nih.gov\]](https://pubmed.ncbi.nlm.nih.gov/)
- [3. Photolabile protecting group - Wikipedia \[en.wikipedia.org\]](https://en.wikipedia.org/)
- [4. application.wiley-vch.de \[application.wiley-vch.de\]](https://application.wiley-vch.de)
- [5. researchgate.net \[researchgate.net\]](https://researchgate.net)
- To cite this document: BenchChem. [Application Note: Controlled Release of Biomolecules using 5-Methyl-2-nitrobenzyl Chloride]. BenchChem, [2026]. [Online PDF]. Available at: [\[https://www.benchchem.com/product/b1586813/docs#application-note-controlled-release-of-biomolecules-using-5-methyl-2-nitrobenzyl-chloride\]](https://www.benchchem.com/product/b1586813/docs#application-note-controlled-release-of-biomolecules-using-5-methyl-2-nitrobenzyl-chloride)

Disclaimer & Data Validity:

The information provided in this document is for Research Use Only (RUO) and is strictly not intended for diagnostic or therapeutic procedures. While BenchChem strives to provide accurate protocols, we make no warranties, express or implied, regarding the fitness of this product for every specific experimental setup.

Technical Support: The protocols provided are for reference purposes. Unsure if this reagent suits your experiment?

Need Industrial/Bulk Grade? [Request Custom Synthesis Quote](#)

BenchChem

Our mission is to be the trusted global source of essential and advanced chemicals, empowering scientists and researchers to drive progress in science and industry.

Contact

Address: 3281 E Guasti Rd

Ontario, CA 91761, United States

Phone: (601) 213-4426

Email: info@benchchem.com

Contact our Ph.D. Support Team for a compatibility check