

# Application Note: Chemoselective Catalytic Functionalization of 3-Chloro-3',4'-dimethoxybenzophenone

**Author:** BenchChem Technical Support Team. **Date:** May 2026

## Compound of Interest

Compound Name:	3-Chloro-3',4'-dimethoxybenzophenone
CAS No.:	116412-84-1
Cat. No.:	B1586548

[Get Quote](#)

## Introduction & Chemical Profile[1][2][3][4][5][6]

**3-Chloro-3',4'-dimethoxybenzophenone** (CDMB) represents a "privileged scaffold" in drug discovery, combining an electron-deficient aryl chloride ring with an electron-rich veratrole (dimethoxybenzene) moiety. This electronic asymmetry allows for highly chemoselective catalytic functionalization.

Unlike simple benzophenones, CDMB offers two distinct sites for catalytic divergence:

- **The Meta-Chloride Handle:** A site for Palladium/Nickel-catalyzed cross-coupling (C-C, C-N bond formation). The meta position is electronically distinct from the more common para-chloro analogs (e.g., Fenofibrate intermediates), requiring specific ligand systems for oxidative addition.
- **The Diaryl Ketone:** A pro-chiral center susceptible to Ruthenium/Iridium-catalyzed Asymmetric Transfer Hydrogenation (ATH) to generate chiral benzhydrols.

## Chemical Properties Table

Property	Specification
Molecular Formula	C <sub>15</sub> H <sub>13</sub> ClO <sub>3</sub>
Molecular Weight	276.72 g/mol
Appearance	White to pale yellow crystalline solid
Melting Point	110–112 °C
Solubility	Soluble in DCM, THF, Toluene; Insoluble in Water
Electronic Character	Ring A (3-Cl): Electron-withdrawing (mild); Ring B (3',4'-OMe): Electron-donating

## Strategic Catalytic Workflows

The utility of CDMB lies in its ability to serve as a lynchpin in divergent synthesis. We define two primary catalytic workflows: Suzuki-Miyaura Cross-Coupling (for scaffold extension) and Asymmetric Transfer Hydrogenation (for chiral center generation).

## Workflow Logic Diagram (Graphviz)

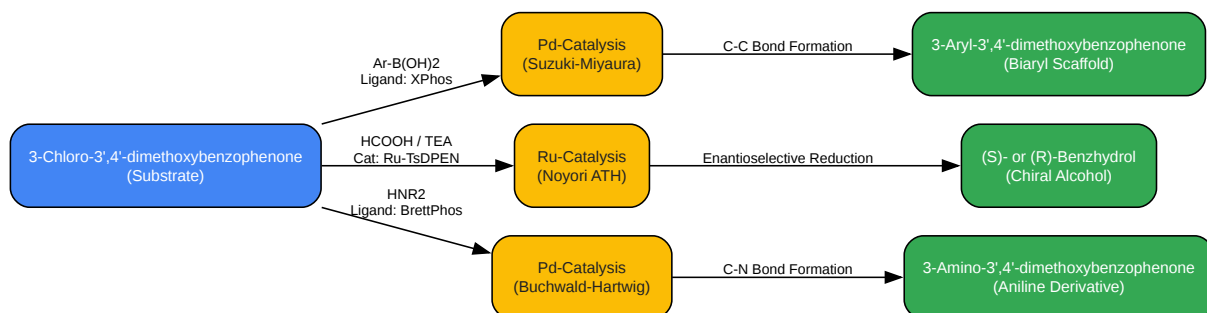

[Click to download full resolution via product page](#)

Figure 1: Divergent catalytic pathways for **3-Chloro-3',4'-dimethoxybenzophenone**. The meta-chloride allows for cross-coupling, while the ketone allows for asymmetric reduction.

## Application 1: Palladium-Catalyzed Suzuki-Miyaura Coupling

The meta-chloro substituent is less activated than a para-chloro group (due to lack of direct resonance conjugation with the carbonyl). Therefore, standard Pd(PPh<sub>3</sub>)<sub>4</sub> catalysts often result in sluggish turnover or homocoupling. This protocol utilizes Buchwald biarylphosphine ligands (XPhos) to facilitate oxidative addition into the challenging meta-C-Cl bond.

### Mechanistic Insight

The electron-rich 3',4'-dimethoxy ring donates electron density into the carbonyl, making the carbonyl oxygen more basic but the carbonyl carbon less electrophilic. However, it has minimal effect on the meta-chloride on the other ring. The challenge is purely steric and the bond dissociation energy of the Ar-Cl bond. XPhos is chosen because it forms a monoligated Pd(0) species that is highly active for aryl chlorides.

### Detailed Protocol A: C-C Bond Formation

Objective: Coupling CDMB with Phenylboronic acid.

Reagents:

- Substrate: **3-Chloro-3',4'-dimethoxybenzophenone** (1.0 equiv)
- Coupling Partner: Phenylboronic acid (1.2 equiv)
- Catalyst Precursor: Pd<sub>2</sub>(dba)<sub>3</sub> (1.0 mol%)
- Ligand: XPhos (2.4 mol%)
- Base: K<sub>3</sub>PO<sub>4</sub> (2.0 equiv, anhydrous)
- Solvent: 1,4-Dioxane / Water (4:1 ratio)

Step-by-Step Methodology:

- **Catalyst Pre-formation:** In a glovebox or under Argon, mix Pd<sub>2</sub>(dba)<sub>3</sub> and XPhos in 1,4-Dioxane. Stir at room temperature for 15 minutes to generate the active L-Pd(0) species. Visual Check: Solution typically turns from dark purple/red to a lighter orange/brown.
- **Reaction Assembly:** Add the CDMB substrate, Phenylboronic acid, and finely ground K<sub>3</sub>PO<sub>4</sub> to a reaction vial equipped with a magnetic stir bar.
- **Solvent Addition:** Add the pre-formed catalyst solution and the degassed water.
- **Heating:** Seal the vial and heat to 80°C for 4–6 hours. Note: Monitor by HPLC or TLC (Hexane/EtOAc 4:1). The starting material (R<sub>f</sub> ~0.5) should disappear.
- **Workup:** Cool to room temperature. Dilute with Ethyl Acetate (EtOAc) and wash with water followed by brine. Dry the organic layer over Na<sub>2</sub>SO<sub>4</sub>.<sup>[1]</sup>
- **Purification:** Concentrate under reduced pressure. Purify via flash column chromatography (Silica gel, gradient 0-10% EtOAc in Hexanes).

Expected Yield: >85% Key Troubleshooting: If conversion is low, switch the base to Cs<sub>2</sub>CO<sub>3</sub> or increase temperature to 100°C. The meta-chloride is robust; do not fear thermal decomposition of the substrate.

## Application 2: Asymmetric Transfer Hydrogenation (ATH)

Reducing the ketone in CDMB creates a chiral benzhydrol. Because the two aryl rings are electronically different (one chloro-substituted, one dimethoxy-substituted), chiral Ruthenium catalysts can distinguish the faces of the ketone with high selectivity (enantiomeric excess, ee).

### Mechanistic Insight

The Noyori-Ikariya catalyst (Ru-TsDPEN) operates via a metal-ligand bifunctional mechanism. The Ru center binds the hydride, while the amino proton of the ligand directs the substrate via hydrogen bonding to the carbonyl oxygen. The steric clash between the catalyst's aryl groups and the substrate's bulky 3-Cl-phenyl vs. 3,4-dimethoxyphenyl rings dictates the stereochemical outcome.

## Detailed Protocol B: Enantioselective Ketone Reduction

Objective: Synthesis of (S)-(3-chlorophenyl)(3,4-dimethoxyphenyl)methanol.

Reagents:

- Substrate: CDMB (1.0 equiv)
- Catalyst: RuCl (0.5 mol%)
- Hydrogen Source: Formic Acid / Triethylamine (5:2 azeotropic mixture)
- Solvent: Dichloromethane (DCM) or DMF (for higher solubility)

Step-by-Step Methodology:

- Preparation: Dissolve CDMB in degassed DCM (0.5 M concentration).
- Catalyst Addition: Add the Ruthenium catalyst (solid) to the solution.
- Initiation: Add the HCOOH/TEA mixture (3.0 equiv of hydride source) dropwise at 0°C.
- Reaction: Allow the mixture to warm to room temperature and stir for 12–16 hours. The reaction is typically open to a bubbler to release CO<sub>2</sub> gas.
- Quench: Add saturated NaHCO<sub>3</sub> solution to neutralize excess acid.
- Extraction: Extract with DCM (3x). Wash combined organics with brine.
- Analysis: Determine conversion by <sup>1</sup>H NMR (shift of CH-OH proton) and ee by Chiral HPLC (e.g., Chiralcel OD-H column, Hexane/IPA 90:10).

Expected Results:

- Yield: >90%
- Enantiomeric Excess (ee): >95% (The electronic differentiation between the rings enhances selectivity compared to symmetric benzophenones).

## References

- Friedel-Crafts Acylation Protocols: Prim, D., et al. "Palladium-catalyzed reactions of aryl chlorides." *Tetrahedron* 58.11 (2002): 2041-2075. (Contextualizes the synthesis and stability of chloro-benzophenones).
- Catalytic Cross-Coupling (Suzuki)
  - Martin, R., & Buchwald, S. L. "Palladium-Catalyzed Suzuki-Miyaura Cross-Coupling Reactions of Aryl Halides." *Accounts of Chemical Research* 41.11 (2008): 1461-1473. [Link](#)
  - Application to Benzophenones: Littke, A. F., & Fu, G. C. "Palladium-catalyzed coupling reactions of aryl chlorides."
- Asymmetric Transfer Hydrogenation
  - Noyori, R., & Hashiguchi, S. "Asymmetric Transfer Hydrogenation Catalyzed by Chiral Ruthenium Complexes." *Accounts of Chemical Research* 30.2 (1997): 97-102. [Link](#)
  - Electronic Effects in ATH: Wu, X., et al. "Asymmetric transfer hydrogenation of ketones with formate-triethylamine catalyzed by Ru-TsDPEN." *Journal of the American Chemical Society* 127.30 (2005): 10488-10489.
- Chemical Safety & Data
  - National Center for Biotechnology Information. PubChem Compound Summary for CID 11237953 (Isomer analog). [Link](#)

Disclaimer: This protocol is for research purposes only. All reactions involving transition metal catalysts and halogenated solvents should be performed in a fume hood with appropriate PPE.

### *Need Custom Synthesis?*

*BenchChem offers custom synthesis for rare earth carbides and specific isotopic labeling.*

*Email: [info@benchchem.com](mailto:info@benchchem.com) or [Request Quote Online](#).*

## Sources

- [1. pdf.benchchem.com \[pdf.benchchem.com\]](https://pdf.benchchem.com)
- To cite this document: BenchChem. [Application Note: Chemoselective Catalytic Functionalization of 3-Chloro-3',4'-dimethoxybenzophenone]. BenchChem, [2026]. [Online PDF]. Available at: [<https://www.benchchem.com/product/b1586548/docs#application-note-chemoselective-catalytic-functionalization-of-3-chloro-3-4-dimethoxybenzophenone>]

---

### Disclaimer & Data Validity:

The information provided in this document is for Research Use Only (RUO) and is strictly not intended for diagnostic or therapeutic procedures. While BenchChem strives to provide accurate protocols, we make no warranties, express or implied, regarding the fitness of this product for every specific experimental setup.

**Technical Support:** The protocols provided are for reference purposes. Unsure if this reagent suits your experiment?

**Need Industrial/Bulk Grade?** [Request Custom Synthesis Quote](#)

## BenchChem

Our mission is to be the trusted global source of essential and advanced chemicals, empowering scientists and researchers to drive progress in science and industry.

### Contact

Address: 3281 E Guasti Rd  
Ontario, CA 91761, United States  
Phone: (601) 213-4426  
Email: [info@benchchem.com](mailto:info@benchchem.com)

[Contact our Ph.D. Support Team for a compatibility check](#)