

The Versatile Scaffold: 2-bromo-9H-thioxanthen-9-one in Modern Medicinal Chemistry

Author: BenchChem Technical Support Team. **Date:** January 2026

Compound of Interest

Compound Name: 2-bromo-9H-thioxanthen-9-one

Cat. No.: B1585316

[Get Quote](#)

Introduction: In the landscape of medicinal chemistry, the relentless pursuit of novel molecular scaffolds that can serve as a foundation for the development of new therapeutic agents is paramount. The thioxanthen-9-one core, a sulfur-containing isostere of the naturally occurring xanthone, has garnered significant attention due to its diverse pharmacological activities. Among its derivatives, **2-bromo-9H-thioxanthen-9-one** stands out as a particularly versatile building block. The strategic placement of the bromine atom at the C-2 position provides a reactive handle for a variety of chemical transformations, enabling the synthesis of a diverse library of derivatives. This technical guide provides an in-depth exploration of the applications of **2-bromo-9H-thioxanthen-9-one** in medicinal chemistry research, complete with detailed protocols for the synthesis and biological evaluation of its derivatives.

Core Molecular Data of 2-bromo-9H-thioxanthen-9-one

Property	Value
Molecular Formula	C ₁₃ H ₇ BrOS
Molecular Weight	291.16 g/mol
CAS Number	20077-10-5[1]
Appearance	White to orange to green powder to crystal[1]
Melting Point	164 - 168 °C[1]

Synthetic Applications: A Gateway to Molecular Diversity

The true power of **2-bromo-9H-thioxanthen-9-one** in medicinal chemistry lies in its utility as a synthetic intermediate. The presence of the bromo substituent allows for a range of cross-coupling and substitution reactions, facilitating the introduction of various functional groups and the construction of more complex molecular architectures.

Protocol 1: Synthesis of Schiff Base Derivatives

Schiff base formation is a robust and straightforward method for introducing nitrogen-containing moieties. The reaction of the ketone group of **2-bromo-9H-thioxanthen-9-one** with primary amines yields imines, which can exhibit a wide range of biological activities.[2][3]

Reaction Scheme:

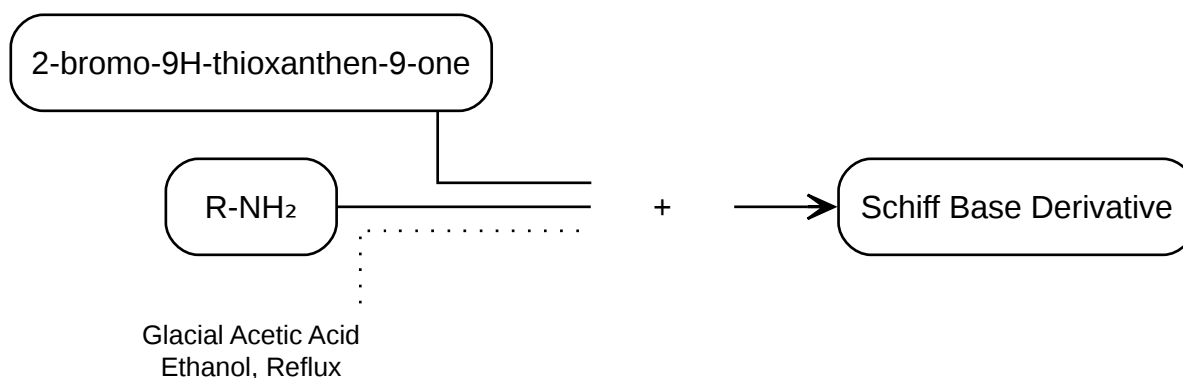

[Click to download full resolution via product page](#)

Caption: General workflow for Schiff base formation.

Step-by-Step Methodology:

- **Reaction Setup:** In a round-bottom flask, combine **2-bromo-9H-thioxanthen-9-one** (1.0 mmol) and the desired primary amine (1.2 mmol) in absolute ethanol (20 mL).
- **Catalyst Addition:** Add a few drops of glacial acetic acid to the mixture to catalyze the reaction.

- **Reflux:** Heat the reaction mixture to reflux and maintain for 4-8 hours. The progress of the reaction can be monitored by Thin Layer Chromatography (TLC).
- **Work-up:** After completion, allow the reaction mixture to cool to room temperature. The precipitated product is collected by vacuum filtration.
- **Purification:** Wash the crude product with cold ethanol to remove any unreacted starting materials. Further purification can be achieved by recrystallization from a suitable solvent, such as ethanol or a mixture of ethanol and water.
- **Characterization:** Confirm the structure of the synthesized Schiff base derivative using spectroscopic techniques such as ^1H NMR, ^{13}C NMR, and mass spectrometry.

Protocol 2: Synthesis of Aminated Tetracyclic Thioxanthenes via Ullmann Condensation

The bromine atom at the C-2 position is susceptible to nucleophilic aromatic substitution, allowing for the introduction of amine functionalities. A notable example is the Ullmann-type C-N coupling reaction to synthesize tetracyclic thioxanthene derivatives, which have shown promising antitumor activity.[3][4]

Reaction Scheme:

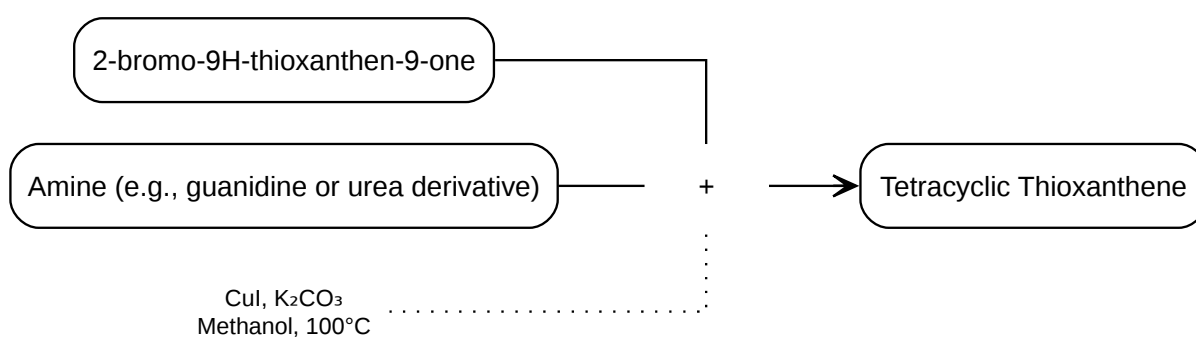

[Click to download full resolution via product page](#)

Caption: Ullmann condensation for tetracyclic thioxanthenes.

Step-by-Step Methodology:

- **Reaction Setup:** In a sealed tube, suspend **2-bromo-9H-thioxanthen-9-one** (0.1 mmol), the appropriate guanidine or urea derivative (0.2 mmol), and potassium carbonate (K_2CO_3 , 0.1 mmol) in methanol (25 mL).
- **Catalyst Addition:** Add copper(I) iodide (CuI, 2 mg) to the suspension.
- **Heating:** Heat the reaction mixture at 100 °C for 48 hours.
- **Work-up:** After cooling, the solvent is removed under reduced pressure. The residue is then partitioned between water and an organic solvent (e.g., dichloromethane).
- **Purification:** The organic layer is separated, dried over anhydrous sodium sulfate, and concentrated. The crude product is purified by flash column chromatography on silica gel.
- **Characterization:** The structure of the final tetracyclic thioxanthene is confirmed by 1H NMR, ^{13}C NMR, and high-resolution mass spectrometry (HRMS).

Advanced Synthetic Strategies: Expanding the Chemical Space

Beyond these fundamental reactions, modern cross-coupling methodologies can be employed to further diversify the derivatives of **2-bromo-9H-thioxanthen-9-one**.

- **Suzuki-Miyaura Coupling:** This palladium-catalyzed reaction allows for the formation of a carbon-carbon bond between the thioxanthenone core and various aryl or vinyl boronic acids or esters. This is a powerful tool for creating biaryl structures with potential applications in areas such as organic electronics and as kinase inhibitors.^[5]
- **Buchwald-Hartwig Amination:** This palladium-catalyzed cross-coupling reaction provides an alternative and often more efficient method for forming carbon-nitrogen bonds. It allows for the coupling of **2-bromo-9H-thioxanthen-9-one** with a wide range of primary and secondary amines under milder conditions than traditional methods.^{[6][7]}

Biological Applications and Evaluation Protocols

Derivatives of **2-bromo-9H-thioxanthen-9-one** have been investigated for a variety of biological activities, with a significant focus on their potential as anticancer agents.

Anticancer Activity and Cytotoxicity Evaluation

The thioxanthenone scaffold is a "privileged structure" in cancer research, with derivatives exhibiting cytotoxicity against various cancer cell lines.[\[8\]](#)[\[9\]](#)[\[10\]](#)

Quantitative Data: Anticancer Activity of Thioxanthenone Derivatives

Compound Class	Derivative	Cancer Cell Line	Activity (IC ₅₀ /GI ₅₀ in μ M)	Reference
Tetracyclic Thioxanthenes	Compound 11	A375-C5 (Melanoma)	5-7	[3]
MCF-7 (Breast Adenocarcinoma)	5-7	[3]		
NCI-H460 (Non-small cell lung)	5-7	[3]		
Compound 14	A375-C5 (Melanoma)	8-11	[3]	
MCF-7 (Breast Adenocarcinoma)	8-11	[3]		
NCI-H460 (Non-small cell lung)	8-11	[3]		
Thioxanthenone-Cysteine Conjugates	Compound 2	Hep G2 (Hepatocellular Carcinoma)	0.1613 \pm 0.041	[9]
Compound 3	Caco-2 (Colon Carcinoma)	0.0096 \pm 0.0011	[9]	

Protocol 3: MTT Assay for In Vitro Cytotoxicity

The MTT (3-(4,5-dimethylthiazol-2-yl)-2,5-diphenyltetrazolium bromide) assay is a colorimetric method used to assess cell viability and proliferation. It is a standard preliminary assay to evaluate the cytotoxic potential of novel compounds.[8]

Experimental Workflow:

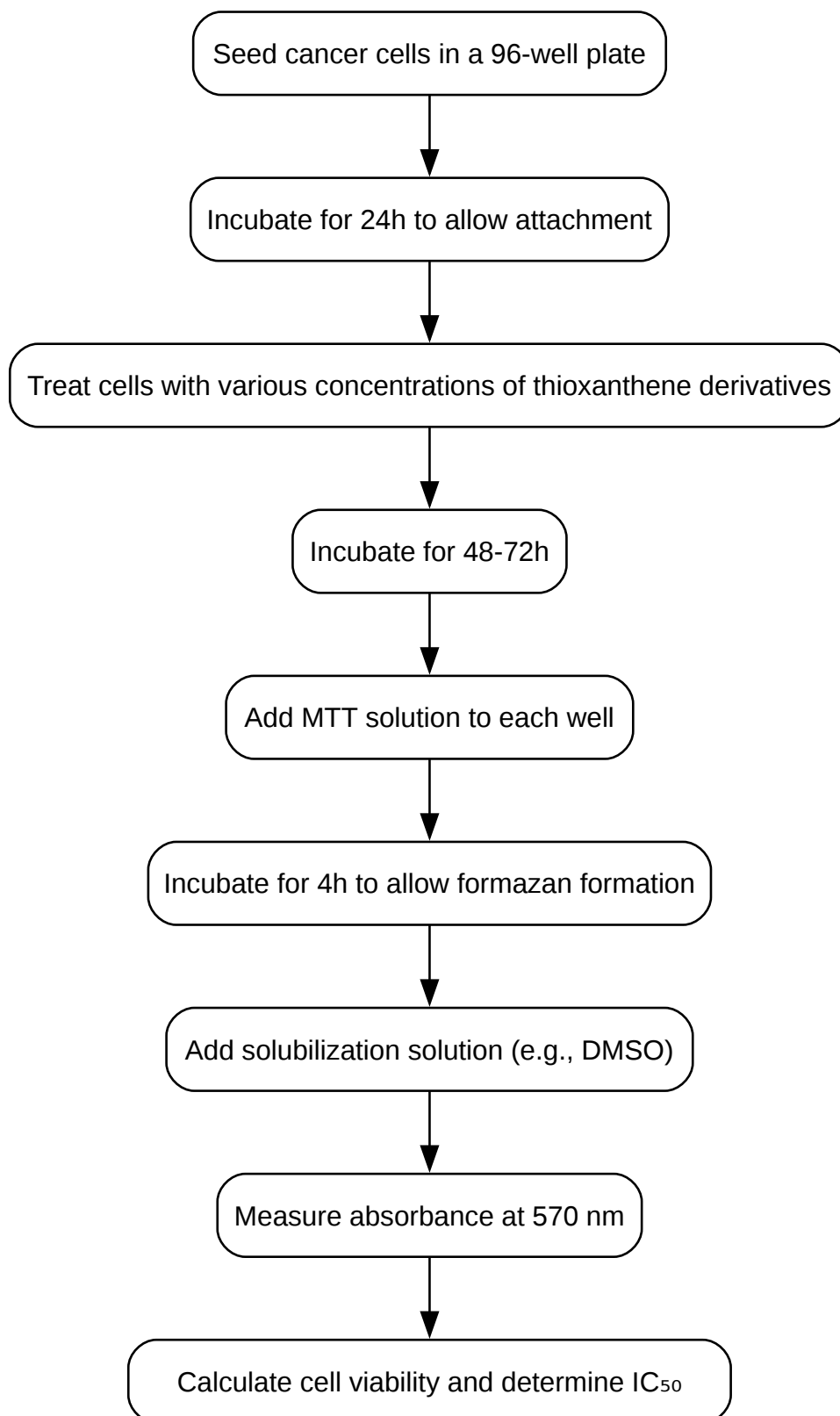

[Click to download full resolution via product page](#)

Caption: Workflow for the MTT cytotoxicity assay.

Step-by-Step Methodology:

- **Cell Seeding:** Seed cancer cells in a 96-well plate at a density of 5,000-10,000 cells per well in 100 μ L of complete culture medium. Incubate for 24 hours at 37°C in a humidified atmosphere with 5% CO₂ to allow for cell attachment.
- **Compound Treatment:** Prepare serial dilutions of the thioxanthene derivatives in culture medium. Remove the old medium from the wells and add 100 μ L of the compound solutions at different concentrations. Include a vehicle control (medium with the same concentration of solvent, e.g., DMSO, used for the highest drug concentration) and a blank control (medium only).
- **Incubation:** Incubate the plate for 48-72 hours at 37°C and 5% CO₂.
- **MTT Addition:** After the incubation period, add 10 μ L of MTT solution (5 mg/mL in PBS) to each well.
- **Formazan Formation:** Incubate the plate for 4 hours in a humidified atmosphere. During this time, metabolically active cells will reduce the yellow MTT to purple formazan crystals.
- **Solubilization:** Add 100 μ L of a solubilization solution (e.g., DMSO or a dedicated solubilizing buffer) to each well to dissolve the formazan crystals. Gently shake the plate to ensure complete dissolution.
- **Absorbance Measurement:** Measure the absorbance of the samples at a wavelength of 570 nm using a microplate reader.
- **Data Analysis:** Calculate the percentage of cell viability for each concentration relative to the vehicle control. Plot the percentage of viability against the compound concentration to determine the half-maximal inhibitory concentration (IC₅₀) value.

Emerging Applications: Fluorescent Probes and Photodynamic Therapy

The unique photophysical properties of the thioxanthene-9-one scaffold open up exciting possibilities beyond traditional pharmacology.

Application as a Fluorescent Probe for Cellular Imaging

Certain thioxanthene derivatives exhibit intrinsic fluorescence, making them promising candidates for the development of fluorescent probes for live-cell imaging. For instance, tetracyclic thioxanthene derivatives have been shown to emit bright intracellular fluorescence, allowing for the visualization of cellular uptake and distribution.[3]

General Protocol for Live-Cell Imaging:

- **Cell Culture:** Plate the cells of interest (e.g., cancer cell lines) on glass-bottom dishes or coverslips and culture until they reach the desired confluency.
- **Probe Incubation:** Treat the cells with the fluorescent thioxanthene derivative at an appropriate concentration (typically in the low micromolar range) in culture medium. Incubate for a specific period to allow for cellular uptake.
- **Washing:** Gently wash the cells with phosphate-buffered saline (PBS) to remove any excess, non-internalized probe.
- **Imaging:** Mount the coverslip on a microscope slide or place the dish directly on the stage of a fluorescence microscope.
- **Image Acquisition:** Acquire images using the appropriate excitation and emission filters for the specific thioxanthene derivative. For example, some derivatives can be excited with a 470 nm light source and emit in the green channel.[3]

Potential in Photodynamic Therapy (PDT)

Photodynamic therapy is a non-invasive cancer treatment that utilizes a photosensitizer, light, and oxygen to generate reactive oxygen species (ROS) that induce cell death. Thioxanthene derivatives are being explored as potential photosensitizers due to their ability to populate the excited triplet state upon light absorption, a key requirement for efficient ROS generation.[2][11] Halogen substitution, such as the bromine in **2-bromo-9H-thioxanthen-9-one**, can enhance the intersystem crossing rate, potentially leading to a higher quantum yield of ROS.[2][11]

Generalized Protocol for Evaluating Phototoxicity:

- **Cell Culture and Compound Incubation:** Follow steps 1 and 2 of the MTT assay protocol to seed cells and treat them with the thioxanthenone derivative. A parallel set of plates should be prepared and kept in the dark to assess dark toxicity.
- **Light Exposure:** Expose the plates to a light source with a wavelength that overlaps with the absorption spectrum of the photosensitizer for a defined period. The light dose (J/cm^2) should be carefully controlled.
- **Post-Irradiation Incubation:** After light exposure, incubate the plates for a further 24-48 hours.
- **Viability Assessment:** Assess cell viability in both the light-exposed and dark control plates using the MTT assay (or another suitable viability assay).
- **Data Analysis:** Compare the cell viability between the light-exposed and dark control groups to determine the phototoxic effect of the compound. The IC_{50} value under light exposure (photo- IC_{50}) can be calculated.

Conclusion and Future Perspectives

2-bromo-9H-thioxanthen-9-one is a highly valuable and versatile scaffold in medicinal chemistry. Its synthetic tractability allows for the creation of diverse molecular libraries with a wide range of biological activities. The demonstrated anticancer potential, coupled with emerging applications in cellular imaging and photodynamic therapy, underscores the continued importance of this compound in drug discovery and chemical biology. Future research will likely focus on the development of more sophisticated synthetic methodologies to access novel derivatives, a deeper understanding of their mechanisms of action, and the optimization of their properties for specific therapeutic and diagnostic applications.

Need Custom Synthesis?

BenchChem offers custom synthesis for rare earth carbides and specific isotopic labeling.

Email: info@benchchem.com or [Request Quote Online](#).

References

- 1. Synthesis and screening of 3-substituted thioxanthen-9-one-10,10-dioxides - PMC [pmc.ncbi.nlm.nih.gov]
- 2. Collection - Exploring Thioxanthone Derivatives as Singlet Oxygen Photosensitizers for Photodynamic Therapy at the Near-IR Region - The Journal of Physical Chemistry A - Figshare [figshare.com]
- 3. mdpi.com [mdpi.com]
- 4. Tetracyclic Thioxanthene Derivatives: Studies on Fluorescence and Antitumor Activity - PMC [pmc.ncbi.nlm.nih.gov]
- 5. Synthetic protocol for diarylethenes through Suzuki–Miyaura coupling - Chemical Communications (RSC Publishing) [pubs.rsc.org]
- 6. mdpi.com [mdpi.com]
- 7. researchgate.net [researchgate.net]
- 8. researchgate.net [researchgate.net]
- 9. Biological Evaluation of Xanthene and Thioxanthene Derivatives as Antioxidant, Anticancer, and COX Inhibitors - PMC [pmc.ncbi.nlm.nih.gov]
- 10. Biological Evaluation of Xanthene and Thioxanthene Derivatives as Antioxidant, Anticancer, and COX Inhibitors | Semantic Scholar [semanticscholar.org]
- 11. Exploring Thioxanthone Derivatives as Singlet Oxygen Photosensitizers for Photodynamic Therapy at the Near-IR Region - PubMed [pubmed.ncbi.nlm.nih.gov]
- To cite this document: BenchChem. [The Versatile Scaffold: 2-bromo-9H-thioxanthen-9-one in Modern Medicinal Chemistry]. BenchChem, [2026]. [Online PDF]. Available at: [https://www.benchchem.com/product/b1585316#2-bromo-9h-thioxanthen-9-one-in-medicinal-chemistry-research]

Disclaimer & Data Validity:

The information provided in this document is for Research Use Only (RUO) and is strictly not intended for diagnostic or therapeutic procedures. While BenchChem strives to provide accurate protocols, we make no warranties, express or implied, regarding the fitness of this product for every specific experimental setup.

Technical Support: The protocols provided are for reference purposes. Unsure if this reagent suits your experiment? [[Contact our Ph.D. Support Team for a compatibility check](#)]

Need Industrial/Bulk Grade? [Request Custom Synthesis Quote](#)

BenchChem

Our mission is to be the trusted global source of essential and advanced chemicals, empowering scientists and researchers to drive progress in science and industry.

Contact

Address: 3281 E Guasti Rd

Ontario, CA 91761, United States

Phone: (601) 213-4426

Email: info@benchchem.com