

Application Note: Visualizing Low Molecular Weight Proteins with Anionic Dyes

Author: BenchChem Technical Support Team. **Date:** April 2026

Compound of Interest

Compound Name: Acid Blue 15

CAS No.: 5863-46-7

Cat. No.: B1585269

[Get Quote](#)

Introduction

The accurate visualization of proteins following separation by polyacrylamide gel electrophoresis (SDS-PAGE) is a cornerstone of proteomics research. While various staining methods exist, anionic dyes offer a robust, cost-effective, and mass spectrometry-compatible solution. This application note provides a detailed protocol for the visualization of low molecular weight (LMW) proteins using a colloidal Coomassie Brilliant Blue G-250 staining method. Coomassie dyes, which belong to the family of acid dyes, are widely utilized for this purpose.[1] [2] Visualizing LMW proteins (typically <20 kDa) presents unique challenges, as these proteins are more prone to diffusion out of the gel matrix during fixation and staining procedures. The protocol outlined here is optimized to enhance the retention and detection of these smaller proteins.

The mechanism of staining involves the non-covalent binding of the dye to proteins.[3] Under acidic conditions, the negatively charged sulfonate groups of the dye interact with positively charged amino acid residues (primarily arginine, lysine, and histidine) through electrostatic interactions.[2][3] Additionally, van der Waals forces and hydrophobic interactions contribute to the stability of the protein-dye complex.[1][3]

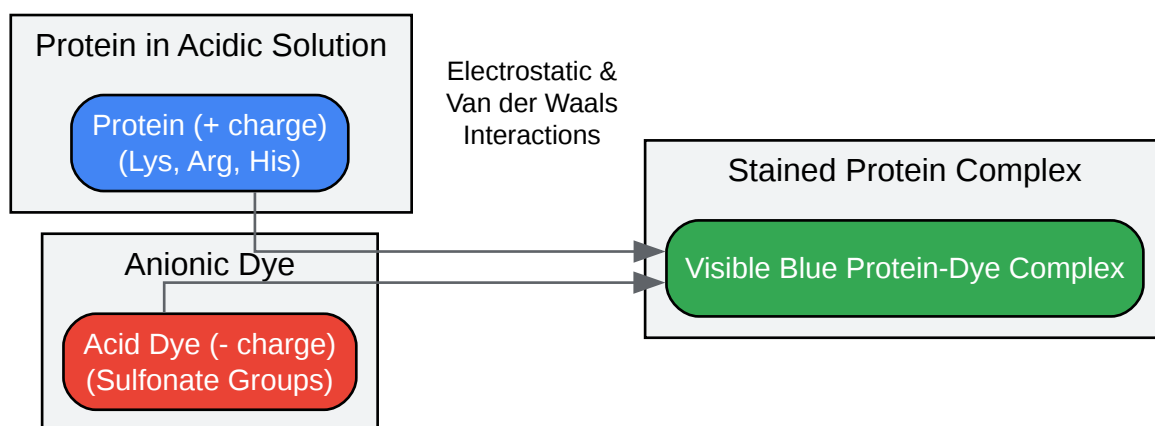

[Click to download full resolution via product page](#)

Figure 1. Mechanism of protein staining by anionic acid dyes.

Quantitative Comparison of Protein Staining Methods

The choice of staining method is critical for achieving the desired sensitivity and compatibility with downstream applications. The following table summarizes the key performance metrics for common protein staining techniques, highlighting the advantages of colloidal Coomassie staining for general laboratory use.

Feature	Colloidal Coomassie G-250	Silver Staining	Fluorescent Dyes (e.g., SYPRO Ruby)
Limit of Detection	8–10 ng[4]	0.25–0.5 ng[4]	0.25–1 ng[4]
Linear Dynamic Range	Moderate[4]	Narrow[4]	>3 orders of magnitude[4]
Mass Spectrometry Compatibility	Yes[1][4]	Limited (requires specific protocols)[4]	Yes[4]
Staining Time	~1 hour to overnight[4]	Multiple steps, time-consuming[4]	90 minutes to overnight[4]
Visualization	Visible light[4]	Visible light[4]	UV or laser-based scanner required[4]
Cost	Low[4]	Low[4]	High[4]
Reproducibility	Good[4]	Low[4]	High[4]

Experimental Protocol: Colloidal Staining for LMW Proteins

This protocol is adapted from standard colloidal Coomassie G-250 staining methods with modifications specifically for enhancing the visualization of low molecular weight proteins. A crucial step is the initial fixation, which cross-links proteins within the gel matrix, preventing LMW proteins from being washed away.

Materials

- Fixing Solution: 50% Methanol, 10% Acetic Acid
- Staining Solution: 0.1% (w/v) Coomassie Brilliant Blue G-250, 2% (v/v) Phosphoric Acid, 10% (w/v) Ammonium Sulfate, 20% (v/v) Methanol
- Washing Solution: Deionized Water

Procedure

- Fixation (Critical for LMW Proteins):
 - Immediately after electrophoresis, immerse the gel in the Fixing Solution. Ensure the gel is fully submerged.
 - Incubate for at least 1 hour with gentle agitation on an orbital shaker. For very small proteins (<10 kDa), extending the fixation time to 2 hours is recommended. This step is essential to precipitate the proteins within the gel and prevent their loss.[5]
- Washing:
 - Decant the fixing solution.
 - Rinse the gel with deionized water three times for 20 minutes each with gentle agitation. This removes the fixative, which can interfere with staining.[4]
- Staining:
 - Submerge the gel in the colloidal Coomassie Staining Solution.
 - Incubate for 1 to 20 hours with constant, gentle shaking.[4] Staining time depends on the desired sensitivity; for LMW proteins, a longer incubation (e.g., overnight) can improve detection.
- Destaining:
 - Decant the staining solution.
 - Destain the gel with deionized water, changing the water every 30-60 minutes until a clear background is achieved and protein bands are sharply defined.[4] Unlike traditional R-250 methods, this protocol does not require an alcohol-based destain, which helps retain LMW proteins.
- Imaging and Storage:
 - Visualize the gel using a densitometer or a standard gel documentation system with a white light transilluminator.

- For long-term storage, the gel can be kept in deionized water at 4°C.

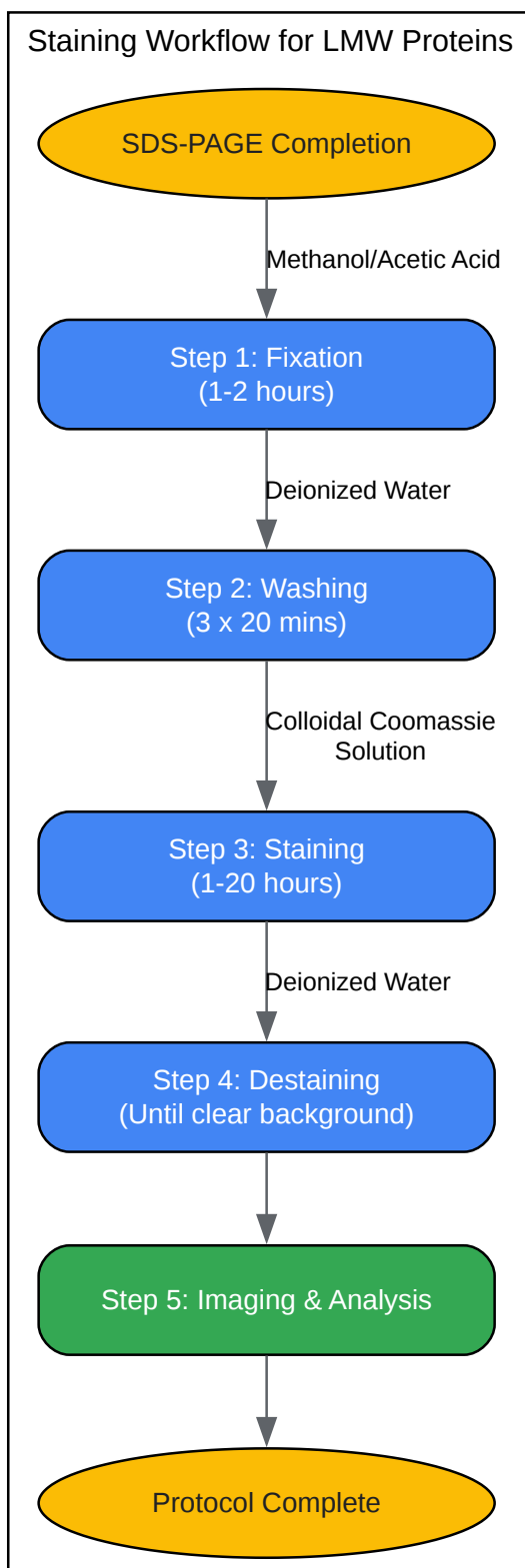

[Click to download full resolution via product page](#)

Figure 2. Experimental workflow for LMW protein visualization.

Downstream Applications: Mass Spectrometry Compatibility

A significant advantage of Coomassie-based staining is its compatibility with mass spectrometry (MS) for protein identification.[4][6] The non-covalent binding mechanism of the dye allows for its efficient removal during the in-gel digestion procedure, minimizing interference with peptide extraction and ionization.

Best Practices for MS Analysis:

- **Handle with Care:** Always wear nitrile gloves and use clean gel trays and razor blades to minimize keratin contamination.[6]
- **Thorough Washing:** After staining, wash the gel thoroughly with ultrapure water before excising bands. This removes residual staining and fixing reagents.[6]
- **Precise Excision:** Carefully cut only the stained protein band, avoiding any surrounding unstained gel areas.
- **Use Fresh Reagents:** Prepare fresh staining and washing solutions to avoid contaminants that can interfere with MS analysis.[6]

Need Custom Synthesis?

BenchChem offers custom synthesis for rare earth carbides and specific isotopic labeling.

Email: info@benchchem.com or [Request Quote Online](#).

References

- 1. info.gbiosciences.com [info.gbiosciences.com]
- 2. [Coomassie blue staining | Abcam](#) [abcam.com]
- 3. carloth.com [carloth.com]
- 4. benchchem.com [benchchem.com]

- [5. mass-spec.chem.ufl.edu](https://mass-spec.chem.ufl.edu) [mass-spec.chem.ufl.edu]
- [6. fredhutch.org](https://fredhutch.org) [fredhutch.org]
- To cite this document: BenchChem. [Application Note: Visualizing Low Molecular Weight Proteins with Anionic Dyes]. BenchChem, [2026]. [Online PDF]. Available at: [<https://www.benchchem.com/product/b1585269/docs#application-note-visualizing-low-molecular-weight-proteins-with-anionic-dyes>]

Disclaimer & Data Validity:

The information provided in this document is for Research Use Only (RUO) and is strictly not intended for diagnostic or therapeutic procedures. While BenchChem strives to provide accurate protocols, we make no warranties, express or implied, regarding the fitness of this product for every specific experimental setup.

Technical Support: The protocols provided are for reference purposes. Unsure if this reagent suits your experiment?

Need Industrial/Bulk Grade? [Request Custom Synthesis Quote](#)

BenchChem

Our mission is to be the trusted global source of essential and advanced chemicals, empowering scientists and researchers to drive progress in science and industry.

Contact

Address: 3281 E Guasti Rd
Ontario, CA 91761, United States
Phone: (601) 213-4426
Email: info@benchchem.com

[Contact our Ph.D. Support Team for a compatibility check](#)