

optimization of liquid chromatography methods for 5-Chlorosalicylanilide

Author: BenchChem Technical Support Team. **Date:** May 2026

Compound of Interest

Compound Name: 5-Chlorosalicylanilide

CAS No.: 4638-48-6

Cat. No.: B1584818

[Get Quote](#)

Technical Support Center: 5-Chlorosalicylanilide (5-CSA) Analysis

Topic: Optimization of Liquid Chromatography Methods for **5-Chlorosalicylanilide** Role: Senior Application Scientist Status: Operational

Physicochemical Profile & Method Strategy

Before troubleshooting, you must understand the molecule. **5-Chlorosalicylanilide** (5-CSA) is not a generic small molecule; it is a halogenated weak acid with significant lipophilicity. Most chromatographic failures stem from ignoring its pKa or solubility profile.

Parameter	Value / Characteristic	Impact on Chromatography
Structure	Phenolic hydroxyl + Amide linker	Prone to hydrogen bonding with silanols (Peak Tailing).
pKa	~6.7 (Phenolic -OH)	CRITICAL: Mobile phase pH must be < 4.5 to keep it neutral. At pH > 6, it ionizes, destroying retention on C18.
LogP	~3.8 - 4.2 (Lipophilic)	Requires high organic strength for elution; risk of carryover in autosamplers.
UV Max	~254 nm (Benzene ring) ~325-330 nm (Conjugated system)	Use 325 nm for higher selectivity against non-fluorescent impurities; 254 nm for general purity.

Core Method Optimization Guide

Q: What is the recommended starting method for 5-CSA?

A: Do not start with a generic 50:50 mix. Due to the halogenation and phenolic nature, I recommend the following "Golden Standard" starting point. This protocol prioritizes peak shape over speed.

Protocol: The "Acid-Lock" Gradient

- Stationary Phase:
 - Recommendation: C18 with high carbon load (>15%) and end-capping.
 - Expert Tip: Use a "T3" style column (e.g., Waters Atlantis T3 or Phenomenex Luna Omega PS C18). These are designed to resist dewetting in high aqueous phases but, more importantly, have superior end-capping that shields the 5-CSA phenol group from active silanols.

- Mobile Phase A (Aqueous): Water + 0.1% Formic Acid (pH ~2.7).
 - Why: You must suppress the ionization of the phenol (pKa 6.7). Phosphate buffer (20mM, pH 3.0) is a valid alternative if you need flatter baselines at 210-220 nm.
- Mobile Phase B (Organic): Acetonitrile (ACN) + 0.1% Formic Acid.
 - Why: ACN provides sharper peaks for halogenated aromatics compared to Methanol, which can increase system pressure and viscosity-driven band broadening.
- Gradient Profile:

Time (min)	% B (ACN)	Event
0.0	40	Initial Hold (Focusing)
1.0	40	Injection pulse clears
10.0	90	Elution of 5-CSA (typically ~7-8 min)
12.0	90	Wash lipophilic impurities
12.1	40	Re-equilibration
15.0	40	Ready for next injection

Troubleshooting & FAQs

Category: Peak Shape Issues

Q: My 5-CSA peak is tailing significantly ($A_s > 1.5$). How do I fix this?

A: Tailing in salicylanilides is almost always "Silanol Sting." The acidic phenol group is interacting with residual silanols on your silica support.

- Immediate Fix 1 (pH Check): Verify your aqueous mobile phase pH. If it has drifted above 4.0, the molecule is partially ionizing. Add 0.1% Formic Acid or adjust Phosphate buffer to pH 3.0.

- Immediate Fix 2 (Ionic Strength): If using Formic Acid, switch to 20mM Ammonium Formate or Potassium Phosphate (pH 3.0). The added salt ions compete with the analyte for silanol sites, effectively "masking" the column.
- Hardware Check: Ensure your needle wash solvent is strong (e.g., 90% ACN). Tailing can sometimes be a "memory effect" from the injector.

Category: Retention Stability

Q: The retention time is shifting earlier with every injection. Why?

A: This is classic "Phase Collapse" or "Dewetting," though less common with 5-CSA's high organic requirement. More likely, your column is fouling.

- The Cause: 5-CSA is often synthesized or extracted from complex matrices containing other lipophilic dimers. These build up on the head of the column, slowly modifying the stationary phase chemistry.
- The Solution: Add a "Sawtooth" wash step. At the end of your run, ramp to 100% ACN for 2 minutes.
- Expert Insight: If you are analyzing biological samples (plasma/tissue), proteins may be binding. Use a guard column and replace it every 100 injections.

Category: Sensitivity[1]

Q: I cannot detect 5-CSA at low concentrations (ng/mL). Is my detector broken?

A: You are likely using the wrong wavelength or technique.

- UV Optimization: While 254 nm is standard, 5-CSA has a secondary absorption band around 325-330 nm. Switching to this wavelength often reduces background noise from solvent cutoffs, increasing Signal-to-Noise (S/N) ratio.
- Fluorescence: If UV is insufficient, 5-CSA is fluorescent.
 - Excitation: 325 nm[1]

- Emission: 480 nm^[1]
- Gain: This can improve sensitivity by 10-100x over UV.

Visualizing the Logic

Workflow: Method Optimization Pathway

This diagram outlines the logical flow for developing a robust method for 5-CSA, prioritizing pH control and column selection.

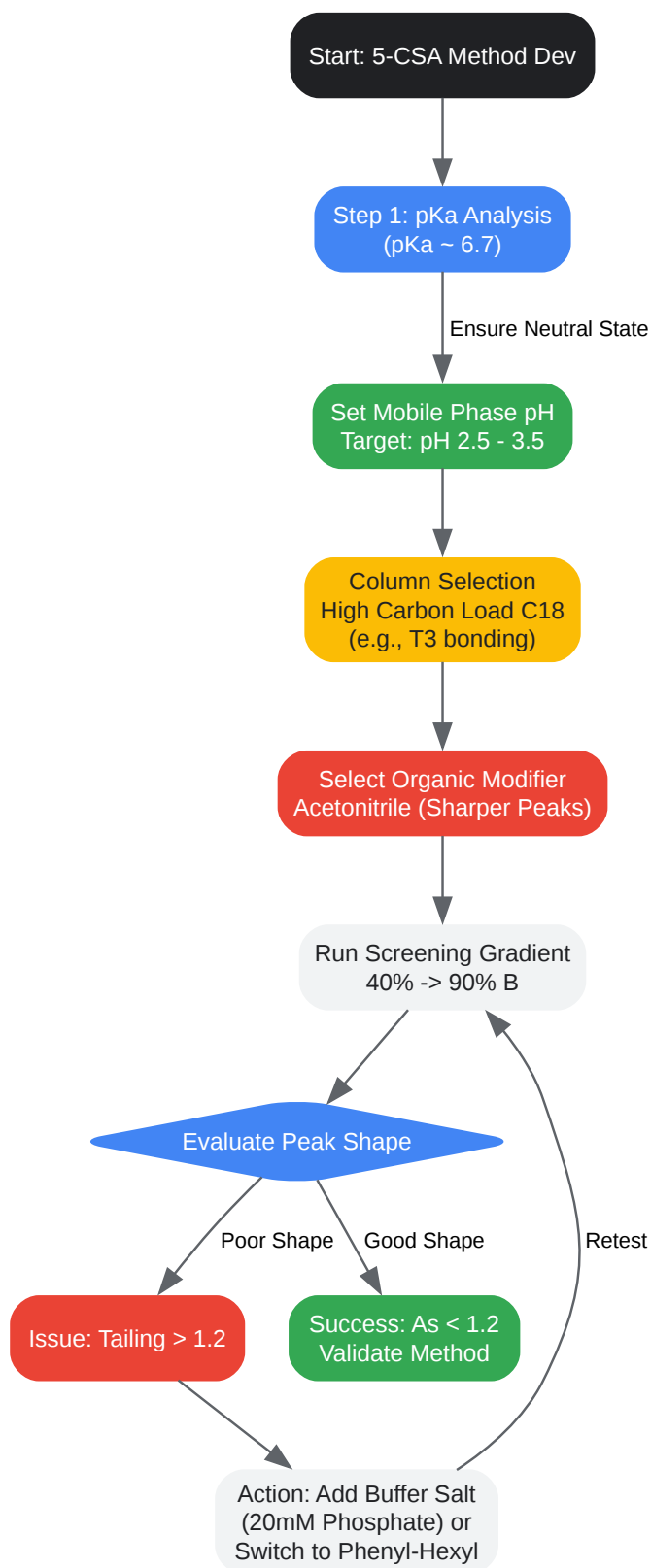

[Click to download full resolution via product page](#)

Caption: Logical workflow for optimizing 5-CSA separation, focusing on pH suppression and column chemistry to mitigate peak tailing.

Workflow: Troubleshooting Decision Tree

Use this tree when you encounter specific failures during routine analysis.

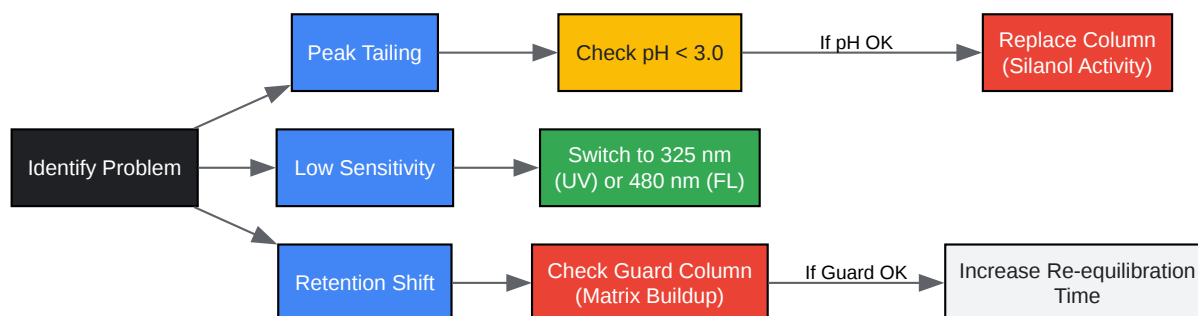

[Click to download full resolution via product page](#)

Caption: Diagnostic decision tree for resolving common 5-CSA chromatographic anomalies.

References

- Wang, L., et al. (2016).[1] "Determination of seven restricted halogenated salicylanilides in cosmetics by high performance liquid chromatography-fluorescence detector." *Analytical Methods*, Royal Society of Chemistry.[1]
- Caldow, M., et al. (2009).[2] "Multi-residue determination of phenolic and salicylanilide anthelmintics... in bovine kidney by liquid chromatography-tandem mass spectrometry." *Journal of Chromatography A*.
- BenchChem. (2025).[3] "High-Performance Liquid Chromatography (HPLC) Analysis of 3',5,5'-Trichlorosalicylanilide." *Application Note*.
- PubChem. "**5-Chlorosalicylanilide** Compound Summary (CID 14869)." National Library of Medicine.

Need Custom Synthesis?

BenchChem offers custom synthesis for rare earth carbides and specific isotopic labeling.

Email: info@benchchem.com or [Request Quote Online](#).

Sources

- 1. Determination of seven restricted halogenated salicylanilides in cosmetics by high performance liquid chromatography - Analytical Methods (RSC Publishing) [pubs.rsc.org]
- 2. Multi-residue determination of phenolic and salicylanilide anthelmintics and related compounds in bovine kidney by liquid chromatography-tandem mass spectrometry - PubMed [pubmed.ncbi.nlm.nih.gov]
- 3. pdf.benchchem.com [pdf.benchchem.com]
- To cite this document: BenchChem. [optimization of liquid chromatography methods for 5-Chlorosalicylanilide]. BenchChem, [2026]. [Online PDF]. Available at: [<https://www.benchchem.com/product/b1584818/docs#optimization-of-liquid-chromatography-methods-for-5-chlorosalicylanilide>]

Disclaimer & Data Validity:

The information provided in this document is for Research Use Only (RUO) and is strictly not intended for diagnostic or therapeutic procedures. While BenchChem strives to provide accurate protocols, we make no warranties, express or implied, regarding the fitness of this product for every specific experimental setup.

Technical Support: The protocols provided are for reference purposes. Unsure if this reagent suits your experiment?

Need Industrial/Bulk Grade? [Request Custom Synthesis Quote](#)

BenchChem

Our mission is to be the trusted global source of essential and advanced chemicals, empowering scientists and researchers to drive progress in science and industry.

Contact

Address: 3281 E Guasti Rd

Ontario, CA 91761, United States

Phone: (601) 213-4426

Email: info@benchchem.com

[Contact our Ph.D. Support Team for a compatibility check](#)