

Technical Monograph: Mechanism of Action of 5-Chlorosalicylanilide (5-CSA)

Author: BenchChem Technical Support Team. **Date:** May 2026

Compound of Interest

Compound Name: 5-Chlorosalicylanilide

CAS No.: 4638-48-6

Cat. No.: B1584818

[Get Quote](#)

Executive Summary

5-Chlorosalicylanilide (5-CSA) represents a canonical scaffold within the salicylanilide class of compounds. While historically recognized for anthelmintic properties, modern pharmacological interest has pivoted toward its capacity as a lipophilic weak acid protonophore.

This guide dissects the molecular mechanics of 5-CSA. Unlike enzyme inhibitors that target a specific active site (lock-and-key), 5-CSA acts as a bioenergetic modulator. Its primary mechanism is the disruption of the proton motive force (PMF) across biological membranes—specifically the Inner Mitochondrial Membrane (IMM) in eukaryotes and the cytoplasmic membrane in Gram-positive bacteria.

Physicochemical Basis of Action: The Proton Shuttle

The efficacy of 5-CSA is dictated by two physicochemical parameters: Lipophilicity (logP) and Acidity (pKa).

The Chemical Mechanism

5-CSA exists in equilibrium between its neutral (protonated) phenolic form and its anionic (deprotonated) form. The chlorine substitution at the 5-position of the salicylic ring is critical; it is an electron-withdrawing group (EWG) that stabilizes the phenolate anion via inductive effects, lowering the pKa to a physiologically relevant range (approx. pKa 6.5–7.5).

- **Membrane Entry:** The neutral form is highly lipophilic, allowing it to diffuse freely through the phospholipid bilayer.
- **Proton Release:** Upon reaching the Matrix side (high pH) or Cytoplasm, the compound dissociates, releasing a proton ().
- **Anion Return:** The resulting anion, stabilized by the amide hydrogen bond and the chloro-group, diffuses back across the membrane along the electrical gradient ().
- **Reloading:** On the Intermembrane Space (IMS) side (low pH), the anion reprotonates, completing the cycle.

Visualization: The Protonophore Cycle

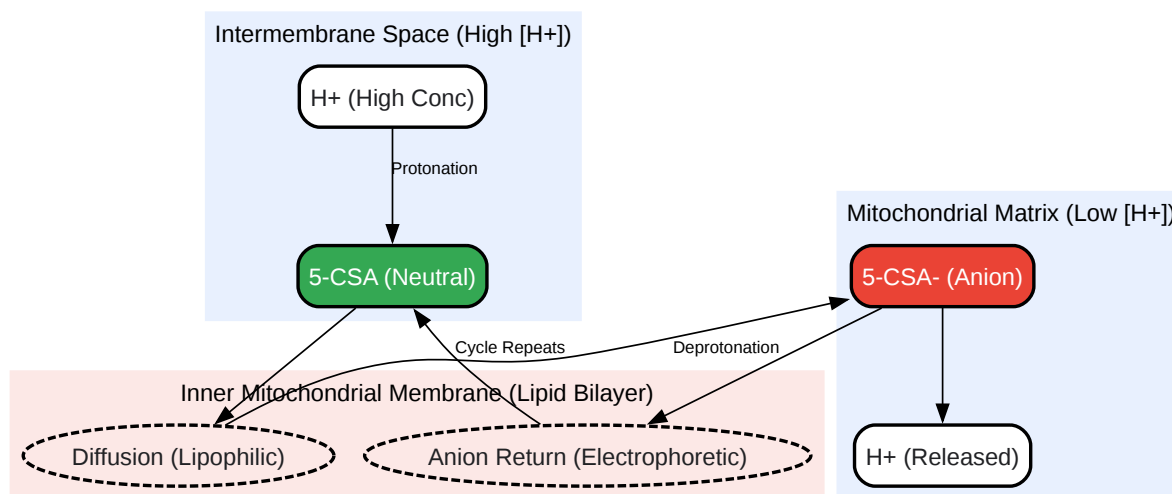

[Click to download full resolution via product page](#)

Figure 1: The futile cycle of proton transport mediated by 5-CSA. The compound short-circuits the proton gradient generated by the Electron Transport Chain.

Biological Mechanisms[1][2][3][4][5]

Eukaryotic Context: Mitochondrial Uncoupling

In mammalian cells, 5-CSA uncouples oxidative phosphorylation. By dissipating the proton gradient (

), it forces the Electron Transport Chain (ETC) to work at maximum velocity to restore the gradient, yet no ATP is synthesized.

- Primary Consequence: Rapid depletion of intracellular ATP.
- Secondary Signaling: The drop in ATP/AMP ratio activates AMPK (AMP-activated protein kinase).

- Downstream Effects: AMPK activation leads to the inhibition of mTORC1 (mechanistic target of rapamycin), inducing autophagy and inhibiting cell proliferation. This is the mechanistic basis for the investigation of salicylanilides in oncology.

Prokaryotic Context: Antibacterial Activity

5-CSA exhibits potent activity against Gram-positive bacteria (e.g., *S. aureus*, MRSA).

- Gram-Positive Selectivity: The thick peptidoglycan layer of Gram-positives is permeable to small lipophilic molecules like 5-CSA. In contrast, the outer membrane of Gram-negatives acts as a barrier, often requiring efflux pump inhibitors or structural modification for 5-CSA to be effective.
- Mechanism: Collapse of the bacterial Proton Motive Force (PMF). This disrupts essential PMF-dependent processes:
 - ATP synthesis (via ATPase).
 - Active transport of nutrients.
 - Cell division (FtsZ ring formation is energy-dependent).

Experimental Validation Protocols

To validate the MOA of 5-CSA in your specific application, the following self-validating protocols are recommended.

Protocol A: Mitochondrial Respiration Profiling (Seahorse Assay)

Objective: Confirm uncoupling activity distinct from ETC inhibition.

Methodology:

- Cell Prep: Seed cells (e.g., HepG2 or HeLa) in XF96 microplates.
- Basal Measurement: Measure Oxygen Consumption Rate (OCR).

- Injection 1 (Oligomycin): Inhibits ATP Synthase. Expected Result: OCR drops (coupled respiration stops).
- Injection 2 (5-CSA Titration): Add 5-CSA (0.5 – 5 μ M).
 - Validation Logic: If 5-CSA is an uncoupler, OCR will spike significantly above basal levels (maximal respiration) despite Oligomycin presence. If it were an inhibitor, OCR would remain low.
- Injection 3 (Rotenone/Antimycin A): Shuts down ETC completely to determine non-mitochondrial respiration.

Data Interpretation Table:

Parameter	5-CSA Effect	Standard Uncoupler (FCCP)	ETC Inhibitor (Rotenone)
Basal Respiration	Increases	Increases	Decreases
ATP Production	Decreases	Decreases	Decreases
Maximal Respiration	Increases (Bell-shaped dose response)	Increases	Decreases
Spare Respiratory Capacity	Consumed	Consumed	Eliminated

Protocol B: Bacterial Membrane Potential Assay (DiSC3(5))

Objective: Quantify the collapse of bacterial membrane potential ().

Methodology:

- Dye Loading: Incubate *S. aureus* (approx

CFU/mL) with 0.4 μM DiSC3(5) (3,3'-dipropylthiadicarbocyanine iodide).

- Equilibration: Wait until fluorescence quenches (dye accumulates in polarized membranes).
- Treatment: Inject 5-CSA.
- Readout: Monitor fluorescence increase (Excitation 622 nm / Emission 670 nm).
 - Causality: As 5-CSA depolarizes the membrane, the dye is released into the medium, causing a fluorescence surge.

Structure-Activity Relationship (SAR) & Optimization

Why "5-Chloro"? The SAR of salicylanilides balances two opposing forces:

- Acidity (pKa): The phenolic -OH must be acidic enough to deprotonate in the matrix.
 - Too weak: Drug stays neutral, no proton transport.
 - Too strong: Drug stays anionic, cannot cross back to the IMS.
 - 5-CSA: The single Chlorine (Cl) provides moderate electron withdrawal, optimizing pKa (~7.0) for physiological cycling.
- Lipophilicity:
 - Too hydrophilic: Cannot cross the membrane.
 - Too lipophilic: Gets "stuck" in the lipid bilayer (the "membrane reservoir" effect).
 - Optimization: 5-CSA is often a starting scaffold. Adding hydrophobic tails (e.g., in Niclosamide) increases potency but decreases solubility.

Visualization: Bioenergetic Logic Flow

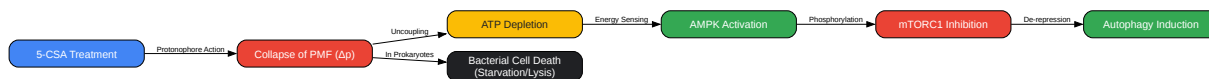

[Click to download full resolution via product page](#)

Figure 2: Downstream signaling cascades initiated by 5-CSA induced membrane depolarization.

References

- Terada, H. (1990). Uncouplers of oxidative phosphorylation.[1][2][3] Environmental Health Perspectives, 87, 213–218. [Link](#)
- Gooyit, M., & Janda, K. D. (2016). Metabolic reprogramming of bacteria by salicylanilides: A dual-action mechanism. ACS Infectious Diseases, 2(11), 820-827. [Link](#)
- Kessler, R. J., & Tyson, C. A. (1976). Mechanism of uncoupling in mitochondria: uncouplers as ionophores for cycling cations and protons.[2] Proceedings of the National Academy of Sciences, 73(9), 3141–3145. [Link](#)
- Urra, F. A., et al. (2013). Mitochondrial uncoupling as a target for drug development. Current Pharmaceutical Design, 19(12), 2262-2283. [Link](#)
- PubChem Compound Summary. (2025). **5-Chlorosalicylanilide** (CID 10332). National Center for Biotechnology Information. [Link](#)

Need Custom Synthesis?

BenchChem offers custom synthesis for rare earth carbides and specific isotopic labeling.

Email: info@benchchem.com or [Request Quote Online](#).

Sources

- [1. Mitochondrial Uncoupling: A Key Controller of Biological Processes in Physiology and Diseases - PMC \[pmc.ncbi.nlm.nih.gov\]](#)
- [2. Mechanism of uncoupling in mitochondria: uncouplers as ionophores for cycling cations and protons - PMC \[pmc.ncbi.nlm.nih.gov\]](#)
- [3. Structural requirements of salicylanilides for uncoupling activity in mitochondria: quantitative analysis of structure-uncoupling relationships - PubMed \[pubmed.ncbi.nlm.nih.gov\]](#)
- [To cite this document: BenchChem. \[Technical Monograph: Mechanism of Action of 5-Chlorosalicylanilide \(5-CSA\)\]. BenchChem, \[2026\]. \[Online PDF\]. Available at: \[https://www.benchchem.com/product/b1584818/docs#technical-monograph-mechanism-of-action-of-5-chlorosalicylanilide-5-csa\]](#)

Disclaimer & Data Validity:

The information provided in this document is for Research Use Only (RUO) and is strictly not intended for diagnostic or therapeutic procedures. While BenchChem strives to provide accurate protocols, we make no warranties, express or implied, regarding the fitness of this product for every specific experimental setup.

Technical Support: The protocols provided are for reference purposes. Unsure if this reagent suits your experiment?

Need Industrial/Bulk Grade? [Request Custom Synthesis Quote](#)

BenchChem

Our mission is to be the trusted global source of essential and advanced chemicals, empowering scientists and researchers to drive progress in science and industry.

Contact

Address: 3281 E Guasti Rd
Ontario, CA 91761, United States
Phone: (601) 213-4426
Email: info@benchchem.com

Contact our Ph.D. Support Team for a compatibility check