

One-Pot Synthesis of Functionalized Pyrimidines: A Detailed Guide for Researchers

Author: BenchChem Technical Support Team. **Date:** May 2026

Compound of Interest

Compound Name:	Methyl 2-amino-6-chloropyrimidine-4-carboxylate
CAS No.:	6299-83-8
Cat. No.:	B1584738

[Get Quote](#)

Introduction: The Strategic Advantage of One-Pot Pyrimidine Synthesis

The pyrimidine nucleus is a cornerstone of medicinal chemistry and drug development, forming the structural core of numerous therapeutic agents with a wide array of biological activities, including anticancer, antibacterial, antiviral, and anti-inflammatory properties.[1][2][3][4][5] The inherent value of this scaffold has driven significant innovation in synthetic organic chemistry, with a particular emphasis on efficiency, sustainability, and the rapid generation of molecular diversity.

One-pot multicomponent reactions (MCRs) have emerged as a powerful strategy to meet these demands.[6] By combining two or more starting materials in a single reaction vessel, MCRs streamline synthetic pathways, reduce waste, and often provide access to complex molecular architectures that would be challenging to assemble through traditional multi-step synthesis.[7] This application note provides a detailed overview of established and robust one-pot methodologies for the synthesis of functionalized pyrimidines, with a focus on the underlying

reaction mechanisms, practical experimental protocols, and data-driven insights for optimization.

Pillar 1: Reaction Mechanisms and Strategic Considerations

A deep understanding of the reaction mechanism is paramount for successful synthesis, troubleshooting, and adaptation of a protocol to new substrates. Here, we delve into the mechanistic underpinnings of one of the most classic and reliable one-pot pyrimidine syntheses: the Biginelli reaction.

The Biginelli Reaction: A Timeless Three-Component Condensation

First reported by Italian chemist Pietro Biginelli in 1891, this acid-catalyzed three-component reaction efficiently combines an aryl aldehyde, a β -ketoester (such as ethyl acetoacetate), and urea (or thiourea) to produce 3,4-dihydropyrimidin-2(1H)-ones (DHPMs).^{[8][9]} These DHPMs are not only valuable pharmaceutical targets in their own right, serving as calcium channel blockers and antihypertensive agents, but also versatile intermediates for further functionalization.^[8]

The reaction mechanism, while subject to some debate over the years, is generally accepted to proceed through a series of bimolecular reactions.^{[8][10]} The most plausible pathway begins with the acid-catalyzed condensation of the aldehyde and urea to form an N-acyliminium ion intermediate. This electrophilic species is then attacked by the enol form of the β -ketoester. Subsequent cyclization via nucleophilic attack of the urea nitrogen onto the ketone carbonyl, followed by dehydration, affords the final dihydropyrimidine product.^[11]

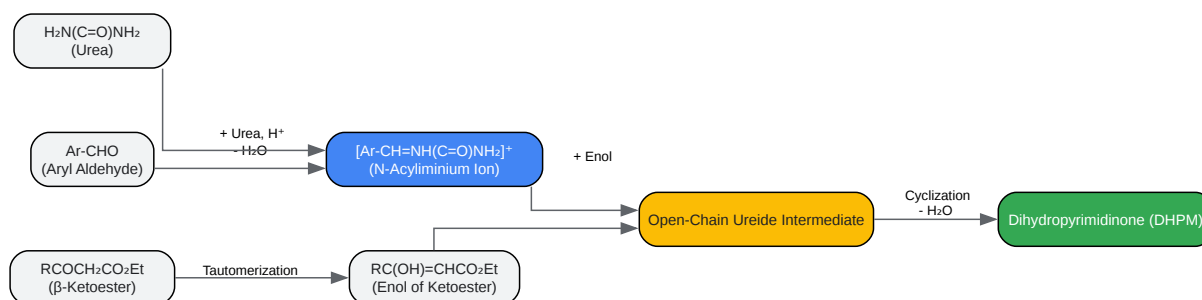

[Click to download full resolution via product page](#)

Caption: Proposed mechanism for the Biginelli reaction.

The choice of catalyst is a critical parameter in the Biginelli reaction. While traditional protocols employ Brønsted acids like HCl or H_2SO_4 , a wide range of Lewis acids (e.g., $\text{Yb}(\text{OTf})_3$, $\text{Bi}(\text{OTf})_3$) and green catalysts (e.g., ionic liquids, enzymes) have been developed to improve yields, shorten reaction times, and facilitate milder reaction conditions.[8][10][12]

Pillar 2: Detailed Experimental Protocols

The following protocols are designed to be self-validating, providing clear, step-by-step instructions for the synthesis of a representative dihydropyrimidinone via the Biginelli reaction.

Protocol 1: Classic Acid-Catalyzed Biginelli Synthesis of a Dihydropyrimidinone

This protocol describes a standard, reliable method for synthesizing ethyl 6-methyl-2-oxo-4-phenyl-1,2,3,4-tetrahydropyrimidine-5-carboxylate.

Materials:

- Benzaldehyde (1.06 g, 10 mmol)
- Ethyl acetoacetate (1.30 g, 10 mmol)

- Urea (0.90 g, 15 mmol)
- Ethanol (20 mL)
- Concentrated Hydrochloric Acid (0.2 mL)
- Ice bath
- Round-bottom flask (100 mL) with reflux condenser
- Stirring bar

Procedure:

- **Reaction Setup:** Combine benzaldehyde (10 mmol), ethyl acetoacetate (10 mmol), urea (15 mmol), and ethanol (20 mL) in a 100 mL round-bottom flask equipped with a magnetic stirring bar.
- **Catalyst Addition:** Slowly add concentrated hydrochloric acid (0.2 mL) to the stirred mixture.
- **Reflux:** Attach a reflux condenser and heat the mixture to reflux (approximately 80-85 °C) with continuous stirring. Monitor the reaction progress using Thin Layer Chromatography (TLC). The reaction is typically complete within 4-6 hours.
- **Isolation:** After completion, cool the reaction mixture to room temperature and then place it in an ice bath for 30 minutes to facilitate precipitation of the product.
- **Filtration and Washing:** Collect the solid product by vacuum filtration. Wash the crude product with cold ethanol (2 x 10 mL) to remove unreacted starting materials and impurities.
- **Drying and Recrystallization:** Dry the product under vacuum. For higher purity, the crude product can be recrystallized from hot ethanol.
- **Characterization:** Confirm the structure and purity of the final product using standard analytical techniques (^1H NMR, ^{13}C NMR, Mass Spectrometry, and Melting Point).

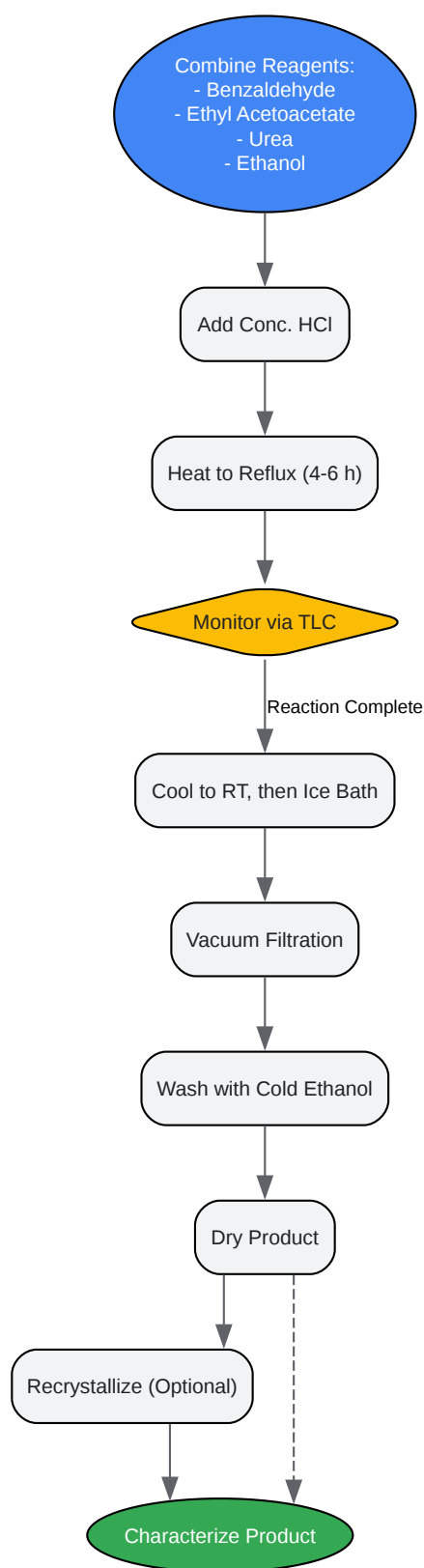

[Click to download full resolution via product page](#)

Caption: Experimental workflow for the Biginelli synthesis.

Pillar 3: Data Presentation and Optimization

The versatility of one-pot pyrimidine syntheses allows for the creation of large, diverse libraries of compounds.^[13] The table below summarizes typical outcomes for the Biginelli reaction with various substituted aldehydes, showcasing the general applicability of the method.

Entry	Aldehyde (Ar-CHO)	Catalyst	Solvent	Time (h)	Yield (%)	Reference
1	Benzaldehyde	HCl	Ethanol	4	~90	[8]
2	4-Chlorobenzaldehyde	Yb(OTf) ₃	Acetonitrile	2	~95	[10]
3	4-Methoxybenzaldehyde	LiClO ₄	Solvent-free	1	~92	[10]
4	3-Nitrobenzaldehyde	Bi(OTf) ₃	Ethanol	3	~88	[12]
5	Furfural	Ionic Liquid	Solvent-free	0.5	~94	[11]

Key Optimization Insights:

- Electron-withdrawing groups on the aryl aldehyde can sometimes lead to slightly lower yields and longer reaction times in classic acid-catalyzed protocols.
- Lewis acid catalysts like Lanthanide triflates often provide higher yields and shorter reaction times under milder, or even solvent-free, conditions.^[11]
- Microwave irradiation has been shown to dramatically reduce reaction times in Hantzsch pyridine synthesis, a principle that can be applied to other MCRs.^[14]

- Green chemistry approaches, such as using water as a solvent or employing reusable catalysts, are becoming increasingly prevalent and effective.[14][15]

Conclusion and Future Outlook

One-pot syntheses of functionalized pyrimidines, exemplified by the robust and versatile Biginelli reaction, represent a cornerstone of modern heterocyclic chemistry. These methods provide an efficient, atom-economical, and scalable route to a class of compounds with immense importance in drug discovery and development.[16] Future innovations will likely focus on the development of even more sustainable catalytic systems, the expansion of substrate scope to include more complex building blocks, and the application of these methodologies in combinatorial chemistry and high-throughput screening for the discovery of new therapeutic leads.[17][18]

References

- Deibl, N., Ament, K., & Kempe, R. (2015). A Sustainable Multicomponent Pyrimidine Synthesis. *Journal of the American Chemical Society*, 137(40), 12804–12807. Available at: [\[Link\]](#)
- Alves, M. F. S., de Souza, M. C. B. V., & Ferreira, V. F. (2017). Aqueous-Phase Multicomponent Reaction Mechanism for the Synthesis of Pyrido[2,3-d]pyrimidines: A Theoretical Perspective. *ACS Omega*, 2(7), 3466–3476. Available at: [\[Link\]](#)
- Deibl, N., Ament, K., & Kempe, R. (2015). A Sustainable Multicomponent Pyrimidine Synthesis. *PubMed*. Available at: [\[Link\]](#)
- Wikipedia. (n.d.). Biginelli reaction. In Wikipedia. Retrieved from [\[Link\]](#)
- Organic Chemistry Portal. (n.d.). Biginelli Reaction. Retrieved from [\[Link\]](#)
- Organic Chemistry Portal. (n.d.). Pyrimidine synthesis. Retrieved from [\[Link\]](#)
- Abdelgawad, M. A., et al. (2022). Recent advancements in the multicomponent synthesis of heterocycles integrated with a pyrano[2,3-d]pyrimidine core. *RSC Advances*, 12(15), 9225-9247. Available at: [\[Link\]](#)

- Al-Ostath, A., et al. (2023). Recent Advances in Pyrimidine-Based Drugs. *Molecules*, 28(15), 5769. Available at: [\[Link\]](#)
- Taylor & Francis. (n.d.). Biginelli reaction – Knowledge and References. Retrieved from [\[Link\]](#)
- Wan, J., & Pan, Y. (2018). A Five-Component Biginelli-Diels-Alder Cascade Reaction. *Frontiers in Chemistry*, 6, 384. Available at: [\[Link\]](#)
- Dey, S., Chakraborty, K., & Ghosh, P. (2024). A Review on Recent One Pot Multi-Component Synthesis and Biological Properties of a Class of New Class of Chromenes, Coumarines, Chromeno-Pyrimidines, Pyrido-Pyrimidine and Quinazoline Heterocycles. *Asian Journal of Applied Chemistry Research*, 15(4), 216-249. Available at: [\[Link\]](#)
- MDPI. (2024). Pyrimidines: A New Versatile Molecule in the Drug Development Field, Scope, and Future Aspects. Retrieved from [\[Link\]](#)
- ResearchGate. (n.d.). Functionalized pyrimidine compounds with their pharmacological potential. Retrieved from [\[Link\]](#)
- SciSpace. (n.d.). Recent advances in Hantzsch 1,4-dihydropyridines. Retrieved from [\[Link\]](#)
- ResearchGate. (n.d.). One-Pot Synthesis of Hantzsch Pyridines via NH₄I Promoted Condensation of 1,3-Dicarbonyl Compounds with DMSO and NH₄OAc. Retrieved from [\[Link\]](#)
- MDPI. (2023). One-Pot Synthesis of Novel Pyrimidine Derivatives with Potential Antidiabetic Activity Through Dual α -Glucosidase and α -Amylase Inhibitors. Retrieved from [\[Link\]](#)
- ResearchGate. (n.d.). An efficient one-pot multi component synthesis of pyrimidine derivatives in aqueous media. Retrieved from [\[Link\]](#)
- Saglam, D., & Turgut, Z. (2022). One-Pot Synthesis of Pyrido[2,3-d]pyrimidines Catalyzed by Bismuth(III)Triflate. *International Journal of Organic Chemistry*, 12, 11-27. Available at: [\[Link\]](#)
- National Institutes of Health. (2022). One-pot synthesis of 4-pyrimidone-2-thioether through base/acid-mediated condensation of S-alkylisothiourea and β -ketoester. *Organic Letters*, 24(31), 5786–5790. Available at: [\[Link\]](#)

- Frutos, R. P., et al. (2005). One-Pot Synthesis of 2,5-Disubstituted Pyrimidines from Nitriles. *The Journal of Organic Chemistry*, 70(24), 10149–10151. Available at: [\[Link\]](#)
- ACS Publications. (2025). Recent Progress in the Synthesis, Functionalization, and Biological Outlook of Pyrimidines. Retrieved from [\[Link\]](#)
- Iranian Journal of Catalysis. (2024). One-pot synthesis of pyrimido[4,5-d]pyrimidine derivatives using a new DABCO-based ionic liquid catalyst. Retrieved from [\[Link\]](#)
- RSC Publishing. (n.d.). Retracted Article: One-pot synthesis of Hantzsch dihydropyridines using a highly efficient and stable PdRuNi@GO catalyst. Retrieved from [\[Link\]](#)
- Wikipedia. (n.d.). Hantzsch pyridine synthesis. In Wikipedia. Retrieved from [\[Link\]](#)
- Research Trend. (n.d.). Exploring the Potential of Pyrimidine: A Comprehensive Review of its Biological Roles, Medicinal Applications, and Synthetic Methodologies in Drug Development. Retrieved from [\[Link\]](#)
- Royal Society Publishing. (2017). Green approach for synthesis of bioactive Hantzsch 1,4-dihydropyridine derivatives based on thiophene moiety via multicomponent reaction. *Royal Society Open Science*, 4(6), 170183. Available at: [\[Link\]](#)
- ResearchGate. (n.d.). Use of Pyrimidine and Its Derivative in Pharmaceuticals: A Review. Retrieved from [\[Link\]](#)
- GSC Advanced Research and Reviews. (2024). Pyrimidine derivatives: Recent discoveries and development towards its medicinal impact. Retrieved from [\[Link\]](#)

Need Custom Synthesis?

BenchChem offers custom synthesis for rare earth carbides and specific isotopic labeling.

Email: info@benchchem.com or [Request Quote Online](#).

Sources

- 1. [mdpi.com](https://www.mdpi.com) [[mdpi.com](https://www.mdpi.com)]

- [2. researchgate.net \[researchgate.net\]](#)
- [3. researchtrend.net \[researchtrend.net\]](#)
- [4. researchgate.net \[researchgate.net\]](#)
- [5. gsconlinepress.com \[gsconlinepress.com\]](#)
- [6. Aqueous-Phase Multicomponent Reaction Mechanism for the Synthesis of Pyrido\[2,3-d\]pyrimidines: A Theoretical Perspective - PMC \[pmc.ncbi.nlm.nih.gov\]](#)
- [7. journalajacr.com \[journalajacr.com\]](#)
- [8. Biginelli reaction - Wikipedia \[en.wikipedia.org\]](#)
- [9. taylorandfrancis.com \[taylorandfrancis.com\]](#)
- [10. Biginelli Reaction \[organic-chemistry.org\]](#)
- [11. jk-sci.com \[jk-sci.com\]](#)
- [12. One-Pot Synthesis of Pyrido\[2,3-d\]pyrimidines Catalyzed by Bismuth\(III\)Triflate \[scirp.org\]](#)
- [13. pubs.acs.org \[pubs.acs.org\]](#)
- [14. Hantzsch pyridine synthesis - Wikipedia \[en.wikipedia.org\]](#)
- [15. royalsocietypublishing.org \[royalsocietypublishing.org\]](#)
- [16. researchgate.net \[researchgate.net\]](#)
- [17. Recent advancements in the multicomponent synthesis of heterocycles integrated with a pyrano\[2,3-d\]pyrimidine core - PMC \[pmc.ncbi.nlm.nih.gov\]](#)
- [18. Recent Progress in the Synthesis, Functionalization, and Biological Outlook of Pyrimidines - PMC \[pmc.ncbi.nlm.nih.gov\]](#)
- To cite this document: BenchChem. [One-Pot Synthesis of Functionalized Pyrimidines: A Detailed Guide for Researchers]. BenchChem, [2026]. [Online PDF]. Available at: [<https://www.benchchem.com/product/b1584738/docs#one-pot-synthesis-of-functionalized-pyrimidines-a-detailed-guide-for-researchers>]

Disclaimer & Data Validity:

The information provided in this document is for Research Use Only (RUO) and is strictly not intended for diagnostic or therapeutic procedures. While BenchChem strives to provide accurate protocols, we make no warranties, express or implied, regarding the fitness of this product for every specific experimental setup.

Technical Support: The protocols provided are for reference purposes. Unsure if this reagent suits your experiment?

Need Industrial/Bulk Grade? [Request Custom Synthesis Quote](#)

BenchChem

Our mission is to be the trusted global source of essential and advanced chemicals, empowering scientists and researchers to drive progress in science and industry.

Contact

Address: 3281 E Guasti Rd
Ontario, CA 91761, United States
Phone: (601) 213-4426
Email: info@benchchem.com

[Contact our Ph.D. Support Team for a compatibility check](#)