

Introduction: The Significance of 4-(4-Bromophenylazo)phenol

Author: BenchChem Technical Support Team. **Date:** May 2026

Compound of Interest

Compound Name: 4-(4-Bromophenylazo)phenol

CAS No.: 3035-94-7

Cat. No.: B1584058

[Get Quote](#)

4-(4-Bromophenylazo)phenol, with CAS Number 3035-94-7, is an aromatic azo compound characterized by a diazo bridge (-N=N-) linking a brominated phenyl ring and a phenolic ring. Its structure is fundamentally a push-pull system; the electron-donating hydroxyl (-OH) group and the electron-withdrawing bromo (-Br) substituent, connected by the π -conjugated azobenzene core, are the primary drivers of its rich chemical and physical properties. This architecture makes BPP and its derivatives prime candidates for investigation in nonlinear optics, chromogenic sensing, and medicinal chemistry. This guide will explore the key research avenues for this compound, moving from its fundamental synthesis to its advanced applications.

Synthesis and Characterization

The synthesis of BPP is a classic example of electrophilic aromatic substitution, specifically a diazotization-coupling reaction, which is a robust and high-yielding method for preparing azo dyes.

Synthesis Pathway

The reaction proceeds in two distinct, temperature-sensitive stages:

- **Diazotization of 4-Bromoaniline:** 4-Bromoaniline is treated with a source of nitrous acid (HNO_2), typically generated in situ from sodium nitrite and a strong mineral acid like hydrochloric acid. This reaction must be conducted at low temperatures ($0\text{--}5\text{ }^\circ\text{C}$) to prevent the highly unstable diazonium salt from decomposing.[1]
- **Azo Coupling with Phenol:** The resulting 4-bromobenzenediazonium salt, a weak electrophile, is then introduced to an activated aromatic compound, phenol. The reaction is performed under alkaline conditions, which deprotonates the phenol to the more strongly activating phenoxide ion, facilitating the electrophilic attack at the para-position to yield the final azo dye.[1]

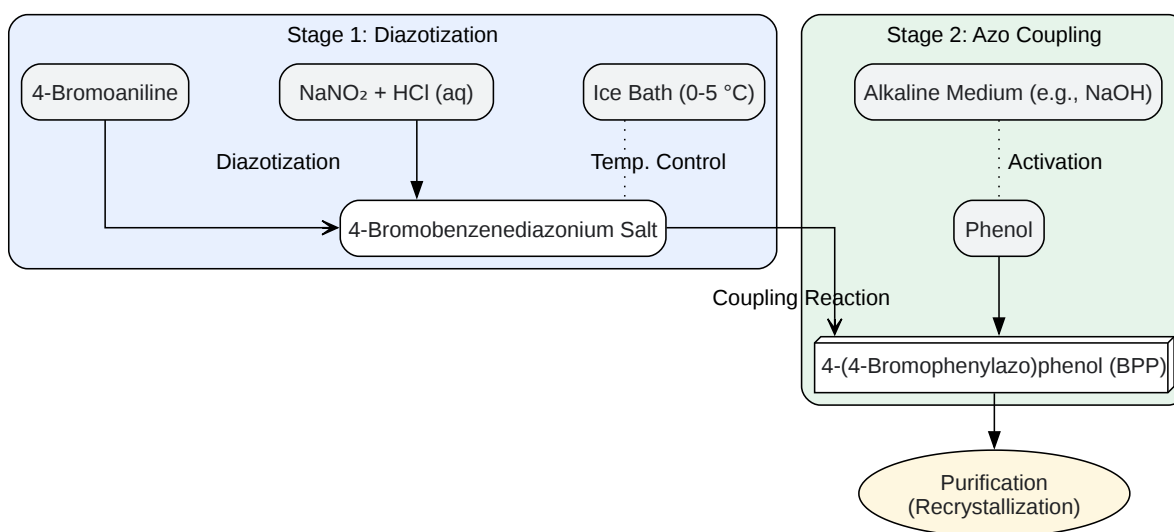

[Click to download full resolution via product page](#)

Caption: General workflow for the synthesis of **4-(4-Bromophenylazo)phenol**.

Structural Characterization

Confirmation of the synthesized BPP structure is achieved through a standard suite of analytical techniques. The data presented below are representative values reported in the literature.

Technique	Parameter	Observed Value/Characteristic	Reference
Melting Point	Range	171-173 °C	[1]
FT-IR (KBr)	Wavenumber (cm ⁻¹)	~3388 (O-H stretch), ~1632 (N=N stretch)	[1]
¹ H NMR (300 MHz, CDCl ₃)	Chemical Shift (δ, ppm)	7.85 (d, 2H), 7.73 (d, 2H), 7.61 (d, 2H), 6.93 (d, 2H), 5.34 (s, 1H, OH)	[1]
¹³ C NMR (75 MHz, CDCl ₃)	Chemical Shift (δ, ppm)	157.8, 150.4, 145.7, 131.1, 124.9, 123.7, 114.4, 94.5	[1]
Molecular Formula	-	C ₁₂ H ₉ BrN ₂ O	[2]
Molecular Weight	g/mol	277.12	[2]

Key Research Applications

The unique electronic and structural features of BPP make it a subject of research in several advanced fields.

Nonlinear Optical (NLO) Materials

Azo dyes are renowned for their significant third-order nonlinear optical properties, which are crucial for applications in optical switching, data storage, and optical limiting.[2] The NLO response in molecules like BPP originates from the delocalized π -electron system that extends from the electron-donating hydroxyl group to the electron-accepting bromo group.

Causality: When an intense laser beam passes through the material, the large, delocalized electron cloud can be easily polarized, leading to a change in the refractive index and

absorption coefficient of the material.[3] This is a key characteristic for all-optical switching devices.[4][5] The Z-scan technique is a standard method to measure the nonlinear refractive index (n_2) and nonlinear absorption coefficient (β).[3][6]

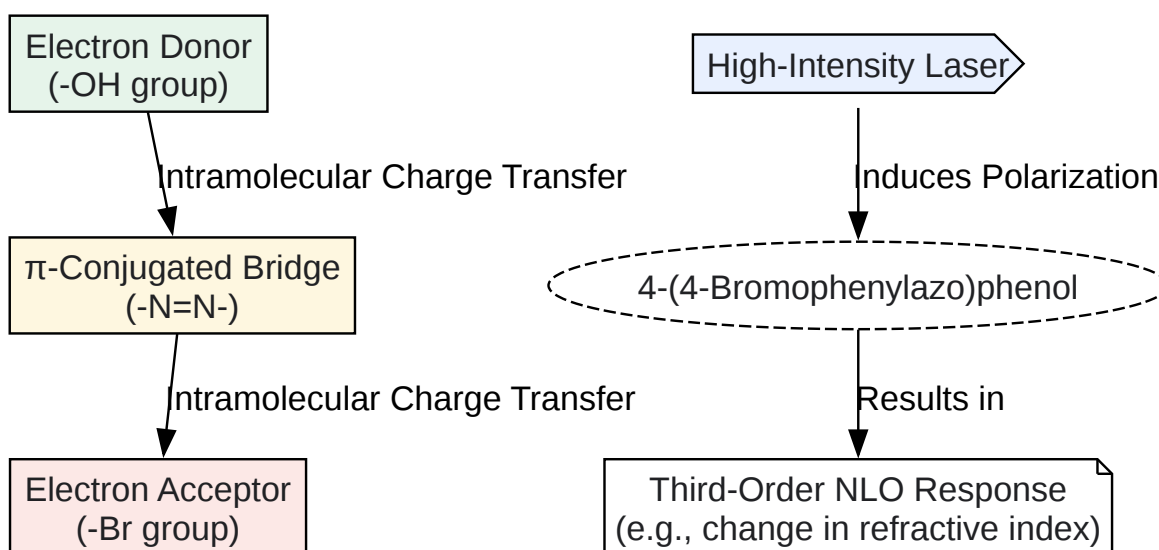

[Click to download full resolution via product page](#)

Caption: Structure-property relationship for NLO activity in BPP.

Antimicrobial and Antifungal Agents

Phenolic compounds are well-established antimicrobial agents.[7] The presence of both a phenol moiety and a halogen (bromine) atom in BPP suggests potential biological activity. Brominated phenols, in particular, have demonstrated efficacy against resilient pathogens, including methicillin-resistant *Staphylococcus aureus* (MRSA).[8][9]

Mechanism of Action: The antimicrobial effect of phenols is generally attributed to their ability to disrupt the bacterial cell membrane, leading to increased permeability and leakage of intracellular components.[10] The lipophilicity imparted by the aromatic rings and the bromine atom can enhance the molecule's ability to penetrate the lipid-rich bacterial cell wall. Studies on various phenolic azo dyes have confirmed activity against both Gram-positive and Gram-negative bacteria, as well as fungal strains like *Candida albicans*. [11][12]

Microorganism	Compound Type	MIC ($\mu\text{g/mL}$)	Reference
Staphylococcus aureus	Phenolic Azo Dye	62.5	[12]
Escherichia coli	Phenolic Azo Dye	62.5	[12]
Salmonella typhi	Phenolic Azo Dye	125	[12]
Candida albicans	Phenolic Azo Dye	125	[12]
Various Candida strains	Azo Phenol Derivative	Good to excellent	[11]

Note: This table presents data for structurally related phenolic azo dyes to indicate the expected range of activity for BPP.

Chromogenic Chemosensors

The vibrant color of azo dyes and its sensitivity to the chemical environment make them excellent candidates for colorimetric sensors.[13][14] BPP can function as a sensor for analytes such as metal ions or for measuring pH.

Sensing Principle: The phenolic -OH group and the nitrogen atoms of the azo bridge can act as binding sites for metal cations.[1] This coordination event alters the intramolecular charge transfer characteristics of the molecule, resulting in a shift in the maximum absorption wavelength (λ_{max}) and a distinct color change visible to the naked eye.[13] Similarly, the deprotonation of the phenolic hydroxyl group under alkaline conditions causes a bathochromic (red) shift in the absorption spectrum, allowing BPP to function as a pH indicator.[15]

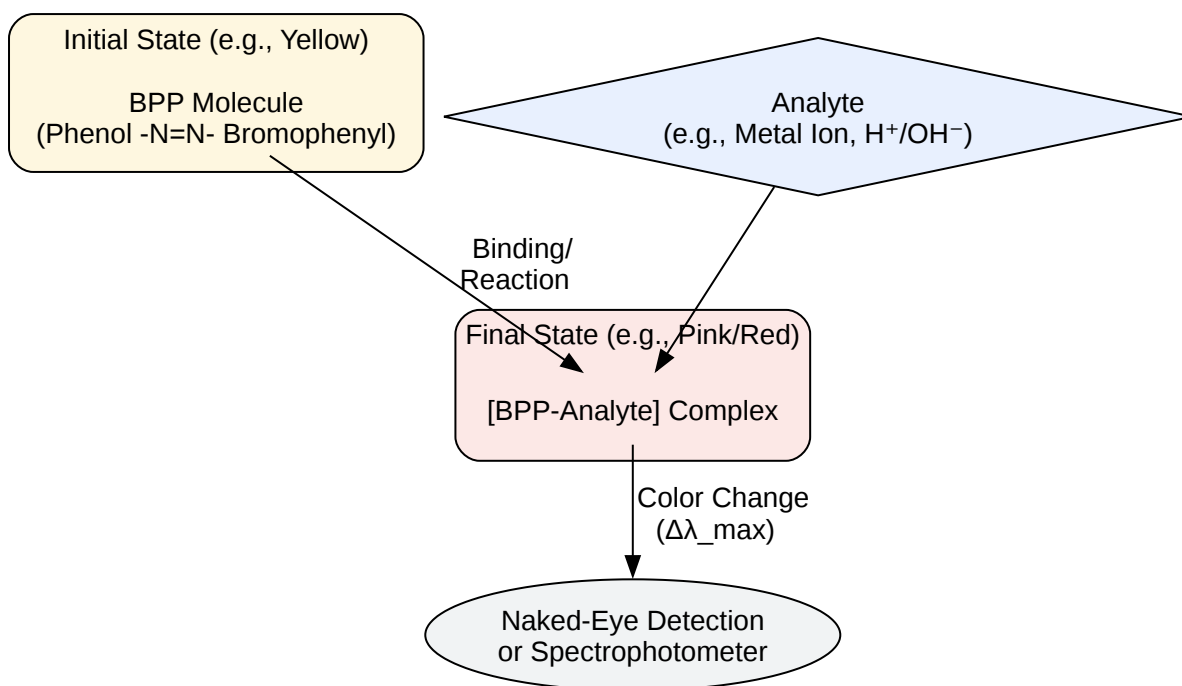

[Click to download full resolution via product page](#)

Caption: Principle of BPP as a colorimetric chemosensor.

Liquid Crystal Precursors

The rigid, rod-like (calamitic) geometry of BPP is a foundational characteristic for designing thermotropic liquid crystals. Molecules with this shape can self-organize into ordered phases (mesophases) that are intermediate between a crystalline solid and an isotropic liquid.

Design Rationale: While BPP itself may not be mesogenic, it serves as an excellent rigid core. Through chemical modification, such as the etherification of the phenolic hydroxyl group with flexible alkyl chains, derivatives of BPP can be synthesized that exhibit nematic or smectic liquid crystal phases. The azobenzene core provides the necessary structural anisotropy, while the terminal chains influence the melting and clearing points of the mesophases. These materials are central to technologies like liquid crystal displays (LCDs).[16]

Experimental Protocols

The following protocols are detailed to provide a practical framework for the synthesis and analysis of BPP and its properties.

Protocol: Synthesis of 4-(4-Bromophenylazo)phenol

Materials:

- 4-bromoaniline
- Concentrated Hydrochloric Acid (HCl)
- Sodium Nitrite (NaNO_2)
- Phenol
- Sodium Hydroxide (NaOH)
- Ethyl Acetate
- Distilled water
- Ice

Procedure:

- Diazotization:
 - In a beaker, dissolve 4-bromoaniline in an aqueous solution of HCl.
 - Cool the mixture to 0-5 °C in an ice-salt bath with constant stirring.
 - Slowly add a pre-cooled aqueous solution of NaNO_2 dropwise. Maintain the temperature below 5 °C throughout the addition.
 - Continue stirring for 15-20 minutes after the addition is complete. The formation of the diazonium salt can be confirmed by a positive test with starch-iodide paper (immediate blue-black color indicates excess nitrous acid).

- Coupling:
 - In a separate beaker, dissolve phenol in an aqueous solution of NaOH and cool it to 5 °C in an ice bath.
 - Slowly add the cold diazonium salt solution to the alkaline phenol solution with vigorous stirring. A colored precipitate will form immediately.
 - Continue stirring the reaction mixture in the ice bath for 30 minutes to ensure the completion of the coupling reaction.
- Work-up and Purification:
 - Filter the crude product using a Büchner funnel and wash the precipitate with cold water to remove excess salts.
 - The product can be purified by recrystallization from a suitable solvent like ethanol or ethyl acetate to yield an orange to brown crystalline solid.[\[1\]](#)
 - Dry the purified product in a vacuum oven.

Protocol: Evaluation as a Colorimetric Cation Sensor

Materials:

- Stock solution of BPP in a suitable solvent (e.g., acetonitrile or ethanol).
- Stock solutions of various metal salts (e.g., CuCl_2 , $\text{Pb}(\text{NO}_3)_2$, FeCl_3) of known concentration.
- UV-Vis Spectrophotometer and cuvettes.

Procedure:

- Preliminary Screening:
 - To a series of test tubes, add a fixed volume of the BPP stock solution.
 - Add an excess of different metal salt solutions to each tube respectively. Include a control tube with only the BPP solution.

- Observe any color changes against a white background. This provides a qualitative indication of sensing ability.[13]
- Spectrophotometric Titration:
 - For the ions that produced a color change, perform a titration.
 - Place a fixed concentration of the BPP solution in a cuvette.
 - Record the initial UV-Vis absorption spectrum (e.g., from 300-700 nm).
 - Add incremental aliquots of a specific metal ion solution to the cuvette, mixing well after each addition.
 - Record the UV-Vis spectrum after each addition.
- Data Analysis:
 - Plot the change in absorbance at the new λ_{max} against the concentration of the added metal ion.
 - This data can be used to determine the binding stoichiometry (e.g., using a Job's plot) and the binding constant of the BPP-metal complex.[17]

Conclusion and Future Outlook

4-(4-Bromophenylazo)phenol stands as a molecule of significant academic and industrial interest due to its straightforward synthesis and versatile functionality. The interplay between its electron-donating and electron-withdrawing groups within a rigid π -conjugated system provides a robust platform for developing advanced materials. Current research highlights its potential in nonlinear optics, as an antimicrobial scaffold, and in the design of chromogenic sensors.

Future research should focus on obtaining specific quantitative data for BPP in these applications, such as determining its first hyperpolarizability (β) for NLO applications and establishing a comprehensive antimicrobial profile with MIC values against a broader panel of clinically relevant pathogens. Furthermore, the synthesis of novel derivatives, particularly for liquid crystal applications and for enhancing selectivity in chemosensing, remains a promising

and fertile area of investigation. The foundational knowledge outlined in this guide serves as a validated starting point for such future endeavors.

References

- Salisu, A. A., et al. (2009). Calamitic Azobenzene Liquid Crystal Series: Synthesis and Mesomorphic Properties of 1-Methoxyalkoxy-4`-(4-phenylazo)acetophenone. Asian Journal of Materials Science, 1, 22-28. Retrieved from [[Link](#)]
- Pinto, S., et al. (n.d.). Synthesis and Evaluation of an Azo Dye for the Chromogenic Detection of Metal Cations. Molbank. Retrieved from [[Link](#)]
- Rahman, M. Z. A., et al. (2009). Nematic Calamitic Bisazobenzene Liquid Crystal: Synthesis and Mesomorphic Properties of 1-Methoxybutyloxy-4`-(4- Phenylazo)Azobenzene. Asian Journal of Applied Sciences, 2, 177-183. Retrieved from [[Link](#)]
- Ali, S., et al. (2021). Spectral Analysis of Azo Derivatives for their Colorimetric Response to some Special Metal Ions. The Official Journal of Science & Technology, 1-13. Retrieved from [[Link](#)]
- Gupta, S., et al. (2025). Innovative azo-based sensors for colorimetric pH detection in extreme alkaline and acidic environments: Computational and experimental insights. ResearchGate. Retrieved from [[Link](#)]
- Olaleye, S. O., & Bibi, U. (2025). A new azo dye for colorimetric determination of lead(II) ions. RSC Publishing. Retrieved from [[Link](#)]
- Hussein, K. A., et al. (n.d.). Synthesis and Nonlinear Optical Studies of a New Azo Compound Derived from 4-Amino-2,3-Dimethyl-1-Phenyl-3-Pyrazol-5-One. Semantic Scholar. Retrieved from [[Link](#)]
- Hussein, K. A., et al. (2023). Synthesis, characterization and nonlinear optical properties of new azo compound using CW laser beam. ResearchGate. Retrieved from [[Link](#)]
- Li, X., et al. (n.d.). A STUDY ON THE SECOND-ORDER NONLINEAR OPTICAL PROPERTIES OF AZO-DYE CHROMOPHORES CONTAINING THE ELECTRON-ACCEPTOR GROUP. ResearchGate. Retrieved from [[Link](#)]

- Ismael, S. M. H., et al. (2024). Synthesize of an Azo Compound: Investigation its Optical Nonlinear Properties and DFT Study. ResearchGate. Retrieved from [\[Link\]](#)
- Hussein, K. A., et al. (n.d.). Nonlinear optical properties of Azo compound synthesized via diazotation reaction using continuous wave laser beams. Semantic Scholar. Retrieved from [\[Link\]](#)
- Wang, Y., et al. (2024). Comprehensive Exploration of Bromophenol Derivatives: Promising Antibacterial Agents against SA and MRSA. PMC - NIH. Retrieved from [\[Link\]](#)
- Căproiu, M. T., et al. (2022). Synthesis, Characterization, DFT Study and Antifungal Activities of Some Novel 2-(Phenyldiazenyl)phenol Based Azo Dyes. MDPI. Retrieved from [\[Link\]](#)
- PubChemLite. (n.d.). **4-(4-bromophenylazo)phenol** (C₁₂H₉BrN₂O). Retrieved January 20, 2026, from [\[Link\]](#)
- ResearchGate. (n.d.). Antibacterial and antifungal activities (in µg/ml) of azo compounds and phenol derivatives against bacterial and yeast species. Retrieved from [\[Link\]](#)
- ResearchGate. (n.d.). Antimicrobial activity of brominated phenoxyphenols. Minimal inhibitory.... Retrieved from [\[Link\]](#)
- Hubble, L. J., et al. (2019). Antimicrobial Activity of Naturally Occurring Phenols and Derivatives Against Biofilm and Planktonic Bacteria. Frontiers in Microbiology. Retrieved from [\[Link\]](#)
- Baashen, M. A., et al. (2021). The crystal structure of 4-(4-bromophenyl)-2-(3-(4-bromophenyl)-5-(4-fluorophenyl)-4,5-dihydro-1H-pyrazol-1-yl)thiazole, C₂₄H₁₆Br₂FN₃S. ResearchGate. Retrieved from [\[Link\]](#)
- MDPI. (2021). Liquid Crystals Based on the N-Phenylpyridinium Cation—Mesomorphism and the Effect of the Anion. MDPI. Retrieved from [\[Link\]](#)
- University of Baghdad Digital Repository. (2022). Heterocyclic compounds-based liquid crystals: Synthesis and mesomorphic properties. Retrieved from [\[Link\]](#)

- ResearchGate. (2025). Synthesis, mesomorphic behaviour and optical anisotropy of some novel liquid crystals with lateral and terminal fluoro substituents and a 2,6-disubstituted naphthalene core. Retrieved from [\[Link\]](#)
- ResearchGate. (2025). Synthesis, characterization and antibacterial activity of some novel azo-azoimine dyes of 6- bromo-2-naphthol. Retrieved from [\[Link\]](#)
- Hubble, L. J., et al. (2019). Antimicrobial Activity of Naturally Occurring Phenols and Derivatives Against Biofilm and Planktonic Bacteria. PMC - NIH. Retrieved from [\[Link\]](#)
- National Institutes of Health. (n.d.). **4-(4-Bromophenylazo)phenol**. PubChem. Retrieved January 20, 2026, from [\[Link\]](#)
- National Institutes of Health. (n.d.). 4-Bromophenol. PubChem. Retrieved January 20, 2026, from [\[Link\]](#)
- Jayasinghe, L., et al. (2020). Synthesis and In Vitro Antimicrobial and Anthelmintic Evaluation of Naphtholic and Phenolic Azo Dyes. PMC - NIH. Retrieved from [\[Link\]](#)
- Sokhraneva, M. (n.d.). Obtaining substituted phenol derivatives with potential antimicrobial activity. Retrieved from [\[Link\]](#)
- ResearchGate. (n.d.). X-ray crystallographic data of compounds 4a, 4b, and 8. Retrieved from [\[Link\]](#)
- ResearchGate. (n.d.). The structure of compound 4 (XRD—X-ray Diffraction). The crystal is a.... Retrieved from [\[Link\]](#)
- National Institutes of Health. (n.d.). 4-Bromobenzophenone. PubChem. Retrieved January 20, 2026, from [\[Link\]](#)
- ResearchGate. (2015). Synthesis, Characterization and X-ray Diffraction Studies on N-(4-Bromophenyl)-4-methoxybenzenesulfonamide. Retrieved from [\[Link\]](#)
- MDPI. (2023). Parametric Characterization of Nonlinear Optical Susceptibilities in Four-Wave Mixing: Solvent and Molecular Structure Effects. MDPI. Retrieved from [\[Link\]](#)

- MDPI. (2011). High Birefringence Liquid Crystals. MDPI. Retrieved from [[Link](#)]
- MDPI. (2018). A Highly Selective Economical Sensor for 4-Nitrophenol. MDPI. Retrieved from [[Link](#)]
- National Institutes of Health. (n.d.). X-Ray Crystallographic Studies of G-Quadruplex Structures. PubMed. Retrieved January 20, 2026, from [[Link](#)]
- DTIC. (n.d.). Open PDF. Retrieved from [[Link](#)]
- ResearchGate. (2025). Liquid crystals — The 'fourth' phase of matter. Retrieved from [[Link](#)]
- ResearchGate. (2025). The Synthesis and Property of Liquid Crystalline 4-Alkoxy-4''-Cyano-p-Terphenyls. Retrieved from [[Link](#)]
- ResearchGate. (2025). Nonlinear characterization and optical switching in bromophenol blue solutions. Retrieved from [[Link](#)]

Need Custom Synthesis?

BenchChem offers custom synthesis for rare earth carbides and specific isotopic labeling.

Email: info@benchchem.com or [Request Quote Online](#).

Sources

1. [mdpi.com](https://www.mdpi.com) [[mdpi.com](https://www.mdpi.com)]
2. 4-(4-Bromophenylazo)phenol | C₁₂H₉BrN₂O | CID 200980 - PubChem [pubchem.ncbi.nlm.nih.gov]
3. [researchgate.net](https://www.researchgate.net) [[researchgate.net](https://www.researchgate.net)]
4. [semanticscholar.org](https://www.semanticscholar.org) [[semanticscholar.org](https://www.semanticscholar.org)]
5. [researchgate.net](https://www.researchgate.net) [[researchgate.net](https://www.researchgate.net)]
6. [semanticscholar.org](https://www.semanticscholar.org) [[semanticscholar.org](https://www.semanticscholar.org)]
7. [Frontiers](https://www.frontiersin.org) | Antimicrobial Activity of Naturally Occurring Phenols and Derivatives Against Biofilm and Planktonic Bacteria [[frontiersin.org](https://www.frontiersin.org)]

- [8. Comprehensive Exploration of Bromophenol Derivatives: Promising Antibacterial Agents against SA and MRSA - PMC \[pmc.ncbi.nlm.nih.gov\]](#)
- [9. researchgate.net \[researchgate.net\]](#)
- [10. Antimicrobial Activity of Naturally Occurring Phenols and Derivatives Against Biofilm and Planktonic Bacteria - PMC \[pmc.ncbi.nlm.nih.gov\]](#)
- [11. Synthesis, Characterization, DFT Study and Antifungal Activities of Some Novel 2-\(Phenyldiazenyl\)phenol Based Azo Dyes \[mdpi.com\]](#)
- [12. Synthesis and In Vitro Antimicrobial and Anthelmintic Evaluation of Naphtholic and Phenolic Azo Dyes - PMC \[pmc.ncbi.nlm.nih.gov\]](#)
- [13. mdpi.com \[mdpi.com\]](#)
- [14. nanobioletters.com \[nanobioletters.com\]](#)
- [15. researchgate.net \[researchgate.net\]](#)
- [16. researchgate.net \[researchgate.net\]](#)
- [17. RSC - Page load error \[pubs.rsc.org\]](#)
- [To cite this document: BenchChem. \[Introduction: The Significance of 4-\(4-Bromophenylazo\)phenol\]. BenchChem, \[2026\]. \[Online PDF\]. Available at: \[https://www.benchchem.com/product/b1584058/docs#introduction-the-significance-of-4-4-bromophenylazo-phenol\]](#)

Disclaimer & Data Validity:

The information provided in this document is for Research Use Only (RUO) and is strictly not intended for diagnostic or therapeutic procedures. While BenchChem strives to provide accurate protocols, we make no warranties, express or implied, regarding the fitness of this product for every specific experimental setup.

Technical Support: The protocols provided are for reference purposes. Unsure if this reagent suits your experiment?

Need Industrial/Bulk Grade? [Request Custom Synthesis Quote](#)

BenchChem

Our mission is to be the trusted global source of essential and advanced chemicals, empowering scientists and researchers to drive progress in science and industry.

Contact

Address: 3281 E Guasti Rd

Ontario, CA 91761, United States

Phone: (601) 213-4426

Email: info@benchchem.com

[Contact our Ph.D. Support Team for a compatibility check](#)