

# Application Note: Precision Surface Functionalization with 2-(Carbomethoxy)ethyltrichlorosilane

**Author:** BenchChem Technical Support Team. **Date:** May 2026

## Compound of Interest

Compound Name:	2-(Carbomethoxy)ethyltrichlorosilane
CAS No.:	18147-81-4
Cat. No.:	B1584619

[Get Quote](#)

## Executive Summary

This guide details the protocol for generating carboxyl-terminated self-assembled monolayers (SAMs) on glass and silica substrates using **2-(Carbomethoxy)ethyltrichlorosilane** (CAS: 18147-81-4). Unlike direct deposition of carboxyl-silanes, which often suffer from aggregate formation due to hydrogen bonding, this precursor utilizes a methyl ester protecting group. This ensures the formation of a pristine, high-density monolayer. The ester is subsequently hydrolyzed to a carboxylic acid, providing a robust platform for bioconjugation (e.g., EDC/NHS coupling) in drug development and biosensor applications.

## Chemical Mechanism & Rationale

### Why 2-(Carbomethoxy)ethyltrichlorosilane?

- Chain Length Control: The ethyl spacer (

) provides a short, rigid linker that minimizes steric freedom, ideal for orienting biomolecules close to the surface.

- Trichlorosilane Anchor: The

headgroup is highly reactive, forming a cross-linked siloxane network (

) at the glass interface. This results in superior thermal and chemical stability compared to mono- or di-alkoxy silanes.

- Ester Protection: The terminal methyl ester (

) is non-reactive during the silanization phase. This prevents the "looping" or disordered binding often seen with native acid-terminated silanes, where the acid tail can interact with surface silanols.

## Reaction Pathway[1][2][3][4][5][6][7]

- Hydrolysis (In-situ): Trace surface water hydrolyzes

bonds to

.

- Condensation: Silanols condense with surface hydroxyls and neighboring silanes to form a covalent network.
- Deprotection: Post-assembly acid hydrolysis converts the methoxycarbonyl group to a reactive carboxylic acid.

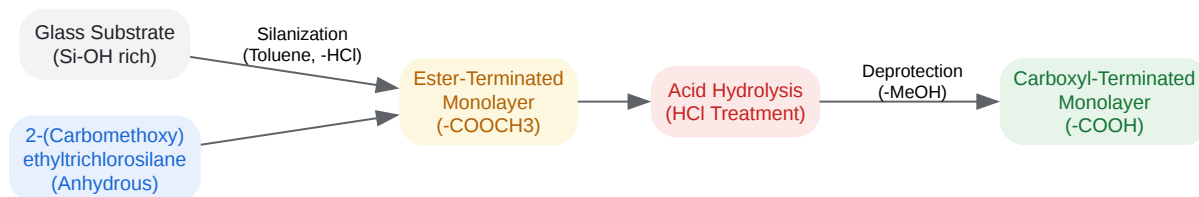

[Click to download full resolution via product page](#)

Figure 1: Reaction pathway from bare glass to functional carboxylic acid surface.

## Safety & Handling

- Hazard: Trichlorosilanes react violently with moisture to release Hydrogen Chloride (HCl) gas.<sup>[1][2]</sup>
- Flammability: The silane and toluene solvent are highly flammable.
- Controls: All silanization steps must be performed in a fume hood or glovebox. Use anhydrous solvents. Double-gloving (Nitrile) and eye protection are mandatory.

## Experimental Protocol

### Phase 1: Surface Preparation (Critical)

Objective: Remove organic contaminants and maximize surface silanol (-OH) density.

- Sonicate glass slides in Acetone (10 min), then Isopropanol (10 min). Dry with stream.
- Piranha Clean: Immerse slides in Piranha solution (3:1 conc. : 30% ) for 30 minutes.
  - Caution: Piranha solution is explosive with organics. Handle with extreme care.
- Rinse: Copious rinsing with Type I Deionized (DI) water (18.2 MΩ).
- Dry: Blow dry with .
- Activation (Optional but Recommended): Treat with Oxygen Plasma (100W, 2 min) immediately before silanization to ensure maximum -OH density.

### Phase 2: Silanization (Anhydrous Deposition)

Objective: Form a dense, covalent ester-terminated monolayer.

- **Reactor Setup:** Use a clean, dry glass staining jar or reaction vessel. Ideally, purge with Nitrogen or Argon.
- **Solvent Preparation:** Prepare Anhydrous Toluene. (Note: Water content must be <50 ppm to prevent bulk polymerization).
- **Silane Solution:** Prepare a 1% (v/v) solution of **2-(Carbomethoxy)ethyltrichlorosilane** in anhydrous toluene.
  - Calculation: For 50 mL toluene, add 500  $\mu$ L silane.
  - Mix immediately.
- **Incubation:** Immerse the clean glass substrates into the silane solution.
  - Time: 60 minutes.
  - Conditions: Room temperature, sealed vessel (to exclude ambient humidity).
- **Washing:**
  - Rinse 2x with Toluene (removes unbound silane).
  - Rinse 2x with Ethanol (removes toluene).
  - Rinse 1x with DI Water.
- **Curing:** Bake slides at 110°C for 15-30 minutes. This promotes covalent cross-linking of the siloxane network.

### Phase 3: Hydrolysis (Deprotection)

Objective: Convert methyl ester to carboxylic acid. Note: Acidic hydrolysis is preferred over basic hydrolysis, as high pH can etch the glass and strip the silane.

- **Acid Solution:** Prepare 1M HCl (aqueous).
  - Alternative: Conc. HCl can be used for faster reaction but requires careful handling.

- Reaction: Immerse the ester-functionalized slides in 1M HCl.
  - Temperature: 60°C.
  - Time: 2 - 4 hours.
- Final Wash: Rinse extensively with DI water to remove all acid traces. Dry with .
- Storage: Store in a desiccator. For best bio-activity, use immediately.

## Characterization & QC

Verify the surface transformation using Contact Angle Goniometry.

Surface Step	Expected Water Contact Angle ( $\theta$ )	Surface Energy State
Piranha Cleaned Glass	< 5°	Superhydrophilic
Ester-Terminated (Phase 2)	65° - 75°	Moderately Hydrophobic
Carboxyl-Terminated (Phase 3)	< 20° - 30°	Hydrophilic (Ionizable)

Table 1: Expected contact angle values indicating successful functionalization.

## Workflow Visualization

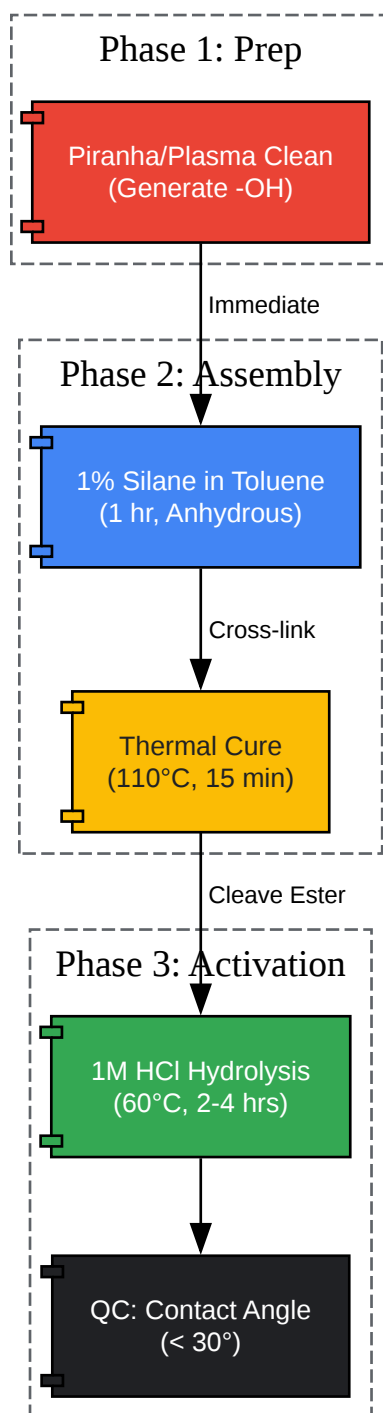

[Click to download full resolution via product page](#)

Figure 2: Step-by-step experimental workflow.

## Troubleshooting

Issue	Probable Cause	Corrective Action
White Haze on Glass	Bulk polymerization due to excess water in toluene.	Use strictly anhydrous toluene; filter silane solution (0.2 $\mu\text{m}$ PTFE) before use.
Low Contact Angle (Phase 2)	Incomplete coverage; surface water layer blocked silane.	Ensure slides are essentially dry before silanization; increase reaction time to 2 hrs.
High Contact Angle (Phase 3)	Incomplete hydrolysis.	Increase HCl temperature to 80°C or use Conc. HCl for 1 hr.

## References

- Gelest, Inc. "Silane Coupling Agents: Connecting Across Boundaries." Gelest Technical Brochures. [\[Link\]](#)
- Arkles, B. "Hydrophobicity, Hydrophilicity and Silane Surface Modification." Gelest, Inc. [\[Link\]](#)
- Plueddemann, E. P. "Silane Coupling Agents." Plenum Press, New York, 1982.
- Hermanson, G. T. "Bioconjugate Techniques." Academic Press, 3rd Edition, 2013.
- Krasnoslobodtsev, A. V., et al. "Effect of water on silanization of silica by trimethoxysilanes." Langmuir, 2002. [\[Link\]](#) (Relevant for understanding moisture sensitivity, though specific to methoxy, principles apply to trichloro).

### Need Custom Synthesis?

BenchChem offers custom synthesis for rare earth carbides and specific isotopic labeling.

Email: [info@benchchem.com](mailto:info@benchchem.com) or [Request Quote Online](#).

## Sources

- 1. ETHYLTRICHLOROSILANE | CAMEO Chemicals | NOAA [[cameochemicals.noaa.gov](https://cameochemicals.noaa.gov)]
- 2. ETHYLTRICHLOROSILANE | CAMEO Chemicals | NOAA [[cameochemicals.noaa.gov](https://cameochemicals.noaa.gov)]

- To cite this document: BenchChem. [Application Note: Precision Surface Functionalization with 2-(Carbomethoxy)ethyltrichlorosilane]. BenchChem, [2026]. [Online PDF]. Available at: [<https://www.benchchem.com/product/b1584619/docs#application-note-precision-surface-functionalization-with-2-carbomethoxy-ethyltrichlorosilane>]

---

### Disclaimer & Data Validity:

The information provided in this document is for Research Use Only (RUO) and is strictly not intended for diagnostic or therapeutic procedures. While BenchChem strives to provide accurate protocols, we make no warranties, express or implied, regarding the fitness of this product for every specific experimental setup.

**Technical Support:** The protocols provided are for reference purposes. Unsure if this reagent suits your experiment?

**Need Industrial/Bulk Grade?** [Request Custom Synthesis Quote](#)

## BenchChem

Our mission is to be the trusted global source of essential and advanced chemicals, empowering scientists and researchers to drive progress in science and industry.

### Contact

Address: 3281 E Guasti Rd

Ontario, CA 91761, United States

Phone: (601) 213-4426

Email: [info@benchchem.com](mailto:info@benchchem.com)

[Contact our Ph.D. Support Team for a compatibility check](#)