

Technical Support Center: Characterization of Poly(3-vinylanisole)

Author: BenchChem Technical Support Team. **Date:** May 2026

Compound of Interest

Compound Name: 1-Methoxy-3-vinylbenzene

CAS No.: 626-20-0

Cat. No.: B1583988

[Get Quote](#)

Welcome to the technical support center for the characterization of poly(3-vinylanisole). This guide is designed for researchers, scientists, and drug development professionals who are working with this unique polymer. Here, you will find in-depth troubleshooting guides, frequently asked questions (FAQs), and detailed experimental protocols to navigate the common challenges encountered during the analysis of poly(3-vinylanisole).

Introduction to Poly(3-vinylanisole) Characterization

Poly(3-vinylanisole) is a vinyl polymer with a methoxy-substituted phenyl group, giving it distinct properties that can present unique challenges during characterization. Accurate determination of its molecular weight, structure, and thermal properties is crucial for its application in various fields. This guide provides practical, field-proven insights to help you obtain reliable and reproducible data.

Section 1: Molecular Weight Determination via Gel Permeation/Size Exclusion Chromatography (GPC/SEC)

Gel Permeation Chromatography (GPC), also known as Size Exclusion Chromatography (SEC), is a fundamental technique for determining the molecular weight and molecular weight distribution (polydispersity index, PDI) of polymers.[1][2]

Troubleshooting Guide & FAQs

Q1: My GPC results for poly(3-vinylanisole) show a broad or multimodal distribution, but I expected a narrow PDI from my controlled polymerization. What could be the issue?

A1: Several factors could contribute to this observation:

- **Polymer Aggregation:** The methoxy group can lead to intermolecular interactions, causing aggregation in certain solvents. This results in the appearance of a high molecular weight shoulder or a separate peak. Try running the GPC at an elevated temperature or using a solvent that disrupts these interactions, such as tetrahydrofuran (THF) with a small amount of a salt like LiBr.
- **Poor Solubility:** If the polymer is not fully dissolved, the insoluble particles can be filtered out by the inline filters, leading to an inaccurate representation of the molecular weight distribution. Ensure complete dissolution, which may require gentle heating and extended agitation.
- **Column Interactions:** The aromatic rings in poly(3-vinylanisole) can interact with the stationary phase of the GPC columns, especially if they are polystyrene-based. This can cause peak tailing or broadening. Using a mobile phase with a slightly different polarity or switching to a different column material can mitigate these effects.[3]

Q2: I am having difficulty choosing the right calibration standards for my GPC analysis of poly(3-vinylanisole). Can I use polystyrene standards?

A2: Yes, polystyrene standards are commonly used for the GPC analysis of vinyl aromatic polymers.[4] However, it's important to remember that this will give you a relative molecular weight, as the hydrodynamic volume of poly(3-vinylanisole) may differ from that of polystyrene of the same molecular weight. For absolute molecular weight determination, you should couple your GPC system with a multi-angle light scattering (MALS) detector.[5]

Q3: My GPC sample preparation is inconsistent. What is the best practice for dissolving poly(3-vinylanisole)?

A3: Achieving complete and consistent dissolution is critical.[6]

- Start with a low concentration, typically 1-2 mg/mL.
- Use a good solvent. Tetrahydrofuran (THF) is often a good starting point. Other potential solvents include chloroform and toluene.
- Allow the polymer to dissolve overnight with gentle stirring. Avoid vigorous shaking, which can cause shear degradation of high molecular weight chains.
- Filter the solution through a 0.2 or 0.45 μm PTFE filter before injection to remove any dust or undissolved particles that could damage the GPC columns.[6]

Experimental Protocol: GPC-MALS Analysis

Objective: To determine the absolute molecular weight and PDI of poly(3-vinylanisole).

Instrumentation:

- HPLC system with a pump, autosampler, and column oven.
- GPC columns suitable for the expected molecular weight range (e.g., a set of polystyrene-divinylbenzene columns).
- Multi-Angle Light Scattering (MALS) detector.
- Refractive Index (RI) detector.

Procedure:

- Mobile Phase Preparation: Prepare filtered and degassed HPLC-grade THF.
- Sample Preparation:
 - Accurately weigh 5-10 mg of poly(3-vinylanisole) into a vial.

- Add 5 mL of THF to achieve a concentration of 1-2 mg/mL.
- Allow the sample to dissolve completely overnight at room temperature with gentle stirring.
- Filter the solution through a 0.2 μm PTFE syringe filter into an autosampler vial.
- Instrument Setup:
 - Equilibrate the GPC system with THF at a flow rate of 1.0 mL/min until the baselines for both the MALS and RI detectors are stable.
 - Set the column oven temperature to 35 °C to ensure reproducibility.
- Data Acquisition: Inject 100 μL of the sample solution and collect the data from both the MALS and RI detectors.
- Data Analysis: Use the software provided with the MALS detector to calculate the absolute molecular weight (M_w), number-average molecular weight (M_n), and PDI (M_w/M_n). The dn/dc value (refractive index increment) for poly(3-vinylanisole) in THF will need to be determined or found in the literature for accurate analysis.

Workflow for GPC Troubleshooting

Caption: Troubleshooting workflow for common GPC/SEC issues.

Section 2: Structural Analysis via NMR and FTIR Spectroscopy

Nuclear Magnetic Resonance (NMR) and Fourier-Transform Infrared (FTIR) spectroscopy are powerful techniques for elucidating the chemical structure of polymers.^{[5][7]}

Troubleshooting Guide & FAQs (NMR)

Q1: The proton NMR spectrum of my poly(3-vinylanisole) has very broad peaks, making it difficult to interpret. What is the cause?

A1: Peak broadening in polymer NMR is common and can be attributed to:

- **High Molecular Weight:** Larger polymers tumble more slowly in solution, leading to shorter T2 relaxation times and broader signals.
- **Restricted Chain Mobility:** The bulky phenyl groups can restrict the motion of the polymer backbone.
- **Viscous Solution:** A high concentration of the polymer can increase the viscosity of the NMR sample, also leading to broader peaks.
- **Paramagnetic Impurities:** Trace amounts of paramagnetic metals from the polymerization catalyst can cause significant peak broadening.

To improve resolution:

- Acquire the spectrum at a higher temperature (e.g., 50 °C) to increase chain mobility and reduce viscosity.
- Use a more dilute sample.
- Ensure all catalyst residues have been removed through proper purification.

Q2: How can I determine the tacticity of my poly(3-vinylanisole) using NMR?

A2: The tacticity (the stereochemistry of the polymer backbone) can be challenging to determine directly from the ¹H NMR due to peak overlap. However, the methoxy protons (-OCH₃) and the aromatic protons may show some sensitivity to the local stereochemical environment. For a more definitive analysis, ¹³C NMR is recommended. The chemical shifts of the backbone carbons are often more sensitive to tacticity, allowing for the quantification of isotactic, syndiotactic, and atactic sequences.

Troubleshooting Guide & FAQs (FTIR)

Q1: My FTIR spectrum of poly(3-vinylanisole) looks very similar to the monomer spectrum. How can I confirm polymerization?

A1: The key is to look for the disappearance of the vinyl group peaks. In the monomer, you will see characteristic peaks for the C=C double bond stretch (around 1630 cm⁻¹) and the vinyl C-H bending vibrations (around 990 and 910 cm⁻¹).^[8] In the polymer, these peaks should be

absent or significantly reduced in intensity. The presence of the aromatic and ether peaks will be common to both the monomer and the polymer.

Data Presentation: Characteristic NMR and FTIR Peaks

Technique	Functional Group	Expected Chemical Shift / Wavenumber
¹ H NMR	Aromatic protons	6.5 - 7.5 ppm (broad)
	Methoxy protons (-OCH ₃)	3.7 - 3.9 ppm (broad)
	Backbone protons (-CH-CH ₂ -)	1.0 - 2.5 ppm (very broad)
¹³ C NMR	Aromatic carbons	110 - 160 ppm
	Methoxy carbon (-OCH ₃)	~55 ppm
	Backbone carbons (-CH-CH ₂ -)	30 - 50 ppm
FTIR	Aromatic C-H stretch	3000 - 3100 cm ⁻¹
	Aliphatic C-H stretch	2850 - 3000 cm ⁻¹
	C-O-C stretch (ether)	1240 - 1260 cm ⁻¹
	Aromatic C=C stretch	1500 - 1600 cm ⁻¹

Experimental Protocol: ¹H NMR Spectroscopy

Objective: To confirm the structure of poly(3-vinylanisole).

Procedure:

- Sample Preparation: Dissolve 10-15 mg of the purified polymer in ~0.7 mL of a deuterated solvent (e.g., CDCl₃ or THF-d₈) in an NMR tube.
- Data Acquisition:
 - Acquire a standard ¹H NMR spectrum.
 - Ensure a sufficient number of scans to obtain a good signal-to-noise ratio.

- Use a relaxation delay (d1) of at least 5 seconds for quantitative analysis.
- Data Processing:
 - Reference the spectrum to the residual solvent peak (e.g., CDCl_3 at 7.26 ppm).
 - Integrate the characteristic peaks to determine the relative number of protons.

Section 3: Thermal Properties via DSC and TGA

Differential Scanning Calorimetry (DSC) and Thermogravimetric Analysis (TGA) are used to determine the thermal transitions and stability of polymers.^{[7][9]}

Troubleshooting Guide & FAQs

Q1: I am not seeing a clear glass transition temperature (T_g) in the DSC thermogram of my poly(3-vinylanisole). Why is this?

A1: The glass transition is a subtle, second-order transition that can sometimes be difficult to detect.

- Thermal History: The thermal history of the sample can significantly affect the appearance of the T_g .^[10] Always analyze the second heating scan after a controlled cooling step to erase the previous thermal history.
- Low Molecular Weight: Low molecular weight polymers may have a very broad or weak T_g .
- Scan Rate: A higher scan rate (e.g., 20 °C/min) can make the T_g more prominent.

Q2: My TGA results show an initial weight loss at a low temperature (< 200 °C). Is my polymer unstable?

A2: This initial weight loss is likely due to the evaporation of residual solvent or moisture, rather than polymer decomposition.^[11] Ensure your polymer sample is thoroughly dried under vacuum before TGA analysis. The main decomposition of the polymer backbone would be expected at a much higher temperature.

Experimental Protocol: DSC Analysis

Objective: To determine the glass transition temperature (T_g) of poly(3-vinylanisole).

Procedure:

- Sample Preparation: Accurately weigh 5-10 mg of the dry polymer into an aluminum DSC pan and seal it.
- Instrument Setup:
 - Place the sample pan and an empty reference pan in the DSC cell.
 - Purge the cell with an inert gas like nitrogen.
- Thermal Program:
 - First Heating Scan: Heat the sample from room temperature to a temperature above the expected T_g (e.g., 150 °C) at a rate of 10 °C/min.
 - Cooling Scan: Cool the sample back to room temperature at a controlled rate (e.g., 10 °C/min).
 - Second Heating Scan: Heat the sample again to 150 °C at 10 °C/min.
- Data Analysis: Determine the T_g from the midpoint of the step transition in the second heating scan.

Logical Diagram for Thermal Analysis

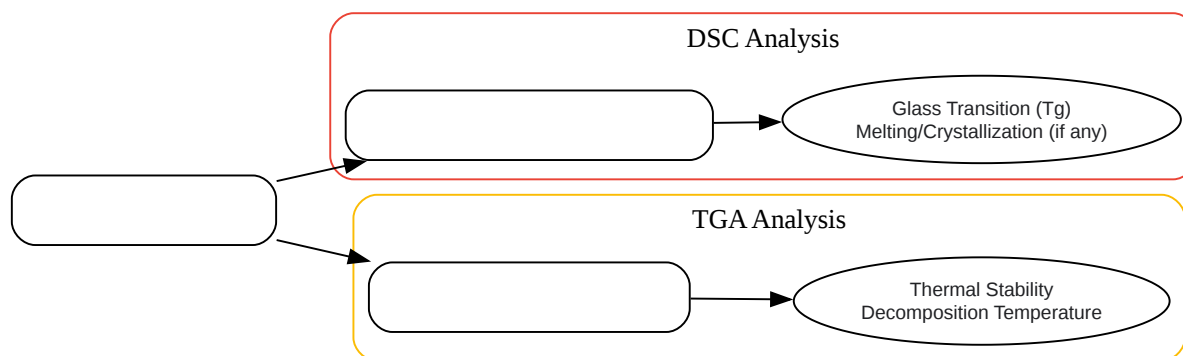

[Click to download full resolution via product page](#)

Caption: Core thermal analysis techniques for polymers.

References

- University of Waterloo. (2018-06-11). TROUBLESHOOTING POLYMERIZATIONS.
- ResolveMass Laboratories Inc. (2025-09-25). Polymer Characterization Techniques Explained.
- Jordi Labs. The Basics of Polymer Analysis: Techniques & Solutions.
- Polymer Chemistry (RSC Publishing). Recent advances in the well-controlled synthesis of poly(vinyl ether)s via cationic polymerization.
- Benchchem. A Comparative Guide to Analytical Techniques for Characterizing Poly((2-Ethoxyethyl) vinyl ether) and its Alternatives.
- SpecialChem. (2021-08-05). Polymer Characterization: How to Get Started.
- Fiveable. Polymer Characterization Techniques to Know for Intro to Polymer Science.
- ResearchGate. Poly(Vinyl Ethers).
- Synthesis and characterization of novel functional vinyl ethers that bear various groups.
- Gel Permeation Chromatography (GPC).
- POLY (VINYL ETHERS) SYNTHESIS FUNDAMENTAL STUDY OF VISCOELASTIC STATE.
- Agilent. An Introduction to Gel Permeation Chromatography and Size Exclusion Chromatography.
- TCU Digital Repository. Polymer studies via gel permeation chromatographic analysis.
- ResolveMass Laboratories Inc. (2025-06-06). Key Challenges and Solutions in Polymer Analysis.
- ResearchGate. FTIR & UV-Vis analysis of polymer sampleS.

- EAG Laboratories. Thermal Analysis Techniques | Polymers.
- (2021-02-15). Practical considerations in Gel Permeation Chromatography analysis of polyolefins.
- Agilent. (2015-04-30). ANALYSIS OF POLYMERS BY GPC/SEC PHARMACEUTICAL APPLICATIONS.
- NETZSCH Analyzing & Testing. (2020-01-31). Material Characterization of Polymers by Methods of Thermal Analysis – A Comprehensive Study on PMMI by Means of DSC, TGA and TGA-FT-IR.
- Nexus Analytics. Thermal Characterization of Polymers.
- TA Instruments. Materials Characterization by Thermal Analysis (DSC & TGA), Rheology, and Dynamic Mechanical Analysis.
- Scilit. (2005-05-16). Synthesis and Characterization of Macrocyclic Vinyl-Aromatic Polymers.
- ResearchGate. (PDF) FTIR & UV-Vis analysis of Polymer(Polystyrene, LDPE) samples.
- Wikipedia. 4-Vinylanisole.
- Benchchem. Application Note: Thermal Analysis of Poly(vinyl stearate) using DSC and TGA.
- Polymer Chemistry (RSC Publishing). Synthesis and characterization of a polyisoprene-b-polystyrene-b-poly(3-hexylthiophene) triblock copolymer.
- RSC Publishing. Challenges in polymer analysis by liquid chromatography.
- VTechWorks. Synthesis, Characterization and Properties of Vinyl Ester Matrix Resins.
- ResearchGate. (2025-08-07). Challenges in polymer analysis by liquid chromatography.
- Sigma-Aldrich. 3-Vinylanisole 97 626-20-0.
- ResearchGate. (2025-08-07). Challenges in the characterization of plasma polymers using XPS.
- UV-Vis and FTIR spectroscopy of gamma irradiated polymethyl methacrylate.
- N94- 36408 MICROSCALE SYNTHESIS AND CHARACTERIZATION OF POLYSTYRENE: NSF-POLYED SCHOLARS PROJECT.
- Oriental Journal of Chemistry. Synthesis and Characterization of New Polymers Derivatives from Copoly (Vinyl Chloride – Vinyl Alcohol).
- Karger Publishers. NMR SPECTROSCOPY AND STEREOREGULARITY OF POLYMERS.
- Universidade de Lisboa. Infrared Spectroscopy for Masterbatch Characterisation Materials Engineering.
- Spectroscopy Online. (2021-11-01). The Infrared Spectra of Polymers III: Hydrocarbon Polymers.
- Sigma-Aldrich. 3-Vinylanisole 97 626-20-0.
- NMR SPECTROSCOPY AND STEREOREGULARITY OF POLYMERS.
- Polymer Source. Poly(styrene-b-4-vinyl pyridine) Sample #: P9006A-S4VP Structure.
- Benchchem. addressing challenges in the characterization of insoluble 2,6-divinylpyridine polymers.

- (2025-12-15). Enhanced Reactivity for the Wagner-Jauregg Reaction Under Aqueous Conditions.
- Accurate Molecular Weight Determination of Polystyrene-Tetrahydrofuran Solutions using the Arc™ HPLC System with a Strong Solv.
- Karbala International Journal of Modern Science. Polystyrene Molecular Weight Determination of Submicron Particles Shell.
- ACS Publications. Solid-State ¹³C MAS NMR Studies of Hyper-Cross-Linked Polystyrene Resins.
- Jordi Labs. Polyethylene Molecular Weight Determination using Standardized GPC and Light Scattering.
- MDPI. (2021-08-08). Characterization of Thermoresponsive Poly-N-Vinylcaprolactam Polymers for Biological Applications.
- UCLA – Chemistry and Biochemistry. (2000-06-22). WebSpectra - Problems in NMR and IR Spectroscopy.

Need Custom Synthesis?

BenchChem offers custom synthesis for rare earth carbides and specific isotopic labeling.

Email: info@benchchem.com or [Request Quote Online](#).

Sources

- [1. benchchem.com](https://www.benchchem.com) [benchchem.com]
- [2. fiveable.me](https://www.fiveable.me) [fiveable.me]
- [3. researchgate.net](https://www.researchgate.net) [researchgate.net]
- [4. jordilabs.com](https://www.jordilabs.com) [jordilabs.com]
- [5. resolve-mass.ca](https://www.resolve-mass.com) [resolve-mass.ca]
- [6. Practical considerations in Gel Permeation Chromatography analysis of polyolefins - Polymer Char](https://www.polymerchar.com) [polymerchar.com]
- [7. resolve-mass.ca](https://www.resolve-mass.com) [resolve-mass.ca]
- [8. benchchem.com](https://www.benchchem.com) [benchchem.com]
- [9. Thermal Analysis Techniques | Polymers | EAG Laboratories](https://www.eag.com) [eag.com]
- [10. specialchem.com](https://www.specialchem.com) [specialchem.com]

- [11. analyzing-testing.netzsch.com \[analyzing-testing.netzsch.com\]](https://www.analyzing-testing.netzsch.com)
- To cite this document: BenchChem. [Technical Support Center: Characterization of Poly(3-vinylanisole)]. BenchChem, [2026]. [Online PDF]. Available at: [\[https://www.benchchem.com/product/b1583988/docs#technical-support-center-characterization-of-poly-3-vinylanisole\]](https://www.benchchem.com/product/b1583988/docs#technical-support-center-characterization-of-poly-3-vinylanisole)

Disclaimer & Data Validity:

The information provided in this document is for Research Use Only (RUO) and is strictly not intended for diagnostic or therapeutic procedures. While BenchChem strives to provide accurate protocols, we make no warranties, express or implied, regarding the fitness of this product for every specific experimental setup.

Technical Support: The protocols provided are for reference purposes. Unsure if this reagent suits your experiment?

Need Industrial/Bulk Grade? [Request Custom Synthesis Quote](#)

BenchChem

Our mission is to be the trusted global source of essential and advanced chemicals, empowering scientists and researchers to drive progress in science and industry.

Contact

Address: 3281 E Guasti Rd
Ontario, CA 91761, United States
Phone: (601) 213-4426
Email: info@benchchem.com

[Contact our Ph.D. Support Team for a compatibility check](#)