

# Introduction: N-Isopropylpropylamine as a Versatile Modifier in Polymer Chemistry

**Author:** BenchChem Technical Support Team. **Date:** May 2026

## Compound of Interest

Compound Name: *N-Isopropylpropylamine*

CAS No.: 21968-17-2

Cat. No.: B1583633

[Get Quote](#)

**N-Isopropylpropylamine** (CAS No. 21968-17-2) is a secondary aliphatic amine characterized by the presence of both an isopropyl and a propyl group attached to a nitrogen atom.[1][2] While not a primary building block for large-scale commodity polymers, its specific structure—possessing a single reactive N-H bond and steric hindrance around the nitrogen—makes it a valuable specialty chemical. It functions not as a primary monomer but as a precise modifying agent, capable of controlling reaction kinetics, polymer architecture, and final material properties in sophisticated coating and plastic formulations.

This guide moves beyond a simple recitation of facts to explore the functional roles of **N-Isopropylpropylamine** from a mechanistic perspective. We will detail its applications as a curing modifier in epoxy systems, a reaction controller in polyurethanes, and a protective agent in anti-corrosion coatings, providing both the theoretical basis and illustrative protocols for its practical implementation.

Property	Value	Reference
CAS Number	21968-17-2	[1][2]
Molecular Formula	C <sub>6</sub> H <sub>15</sub> N	[1][2]
Molecular Weight	101.19 g/mol	[1]
IUPAC Name	N-propan-2-ylpropan-1-amine	[1]
Boiling Point	92-96 °C	[2]
Density	~0.723 g/cm <sup>3</sup>	[2]
Appearance	Colorless Liquid	[3]
Synonyms	N-propylisopropylamine, Propylisopropylamine	[1][2][4]

## Part 1: Application in Epoxy Resin Systems — A Tool for Controlling Crosslink Density

In epoxy chemistry, the curing or crosslinking process is fundamental to developing the final thermoset properties. This reaction typically involves a resin containing epoxide groups and a hardener, most commonly a multifunctional amine.[5][6] The number of active hydrogen atoms on the amine hardener dictates its functionality and role in building the polymer network.

### Core Concept: From Crosslinker to Chain Terminator

Primary amines (R-NH<sub>2</sub>) possess two active hydrogens and are difunctional, enabling them to connect two different epoxy chains and act as a true crosslinker. In contrast, **N-Isopropylpropylamine**, as a secondary amine (R<sub>2</sub>-NH), has only one active hydrogen.[7] Consequently, it is monofunctional in the context of epoxy curing. When it reacts with an epoxide ring, it becomes a tertiary amine and can no longer participate in network formation. This transforms its role from a crosslinking agent to a chain terminator or curing modifier.

This distinction is critical. By strategically incorporating a monofunctional amine like **N-Isopropylpropylamine** into a formulation dominated by primary amines, a researcher can precisely control the final crosslink density of the cured epoxy.

## Mechanism of Action: Modulating Network Architecture

The curing of an epoxy resin with an amine hardener proceeds via the nucleophilic attack of the amine's nitrogen on the carbon atom of the epoxide ring, leading to ring-opening.[7]

- Primary Amine (Crosslinking): Reacts twice to form a stable, three-dimensional network node.
- Secondary Amine (Chain Termination): Reacts once, effectively capping that polymer chain and preventing further extension at that site.

The diagram below illustrates this fundamental difference.

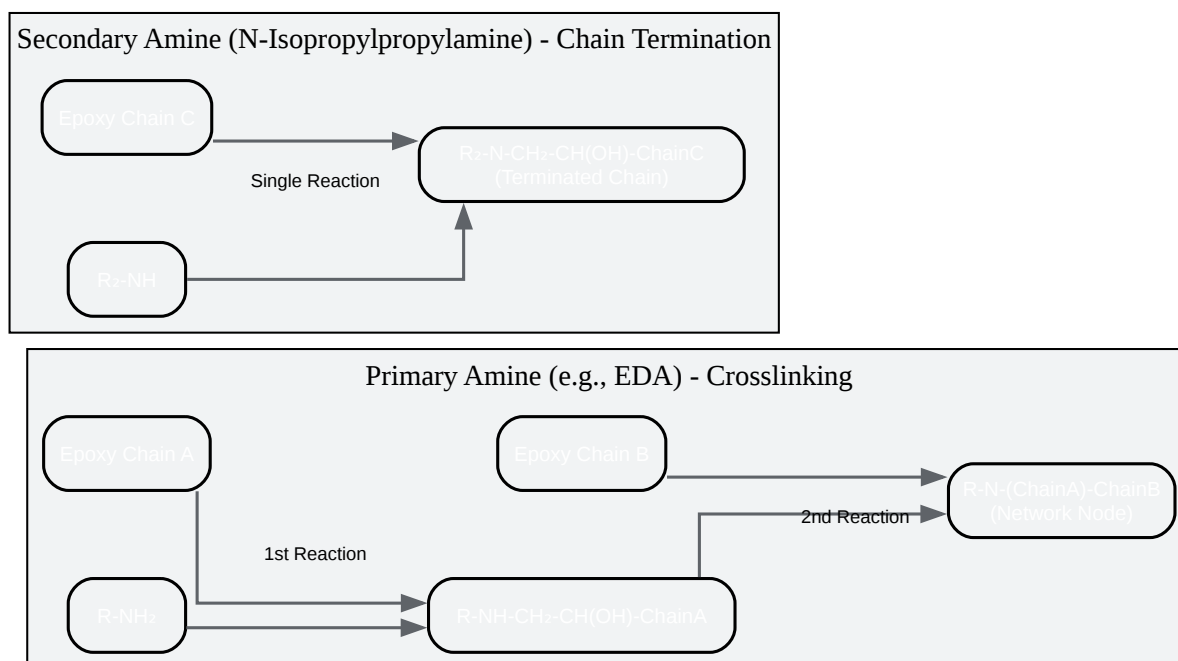

[Click to download full resolution via product page](#)

Caption: Reaction pathways of primary vs. secondary amines with epoxy resins.

## Application Protocol: Evaluating N-Isopropylpropylamine as a Flexibility Modifier

This protocol outlines a method to quantify the effect of **N-Isopropylpropylamine** on the thermomechanical properties of a standard epoxy system.

Objective: To determine the impact of varying concentrations of **N-Isopropylpropylamine** on the glass transition temperature (T<sub>g</sub>) and flexibility of a cured Bisphenol A-based epoxy resin.

Materials:

- Liquid Epoxy Resin (e.g., DGEBA, EEW 182-192 g/eq)
- Primary Amine Hardener (e.g., Diethylenetriamine - DETA)
- **N-Isopropylpropylamine** (Modifier)
- Solvent (if required for viscosity control, e.g., xylene)
- Release-coated molds

Procedure:

- Calculate Stoichiometry: Determine the required mass of the primary hardener (DETA) for the epoxy resin based on the Amine Hydrogen Equivalent Weight (AHEW). The stoichiometric ratio is typically 1:1 of amine hydrogens to epoxy groups.
- Formulation Preparation:
  - Control (0% Modifier): In a suitable container, weigh the epoxy resin. Add the calculated stoichiometric amount of DETA. Mix thoroughly for 2-3 minutes until homogenous.
  - Test Formulations (e.g., 5%, 10%, 20% Modification): For each test batch, calculate the total amine hydrogen equivalents required. Replace 5%, 10%, or 20% of the primary amine (DETA) equivalents with an equivalent amount of **N-Isopropylpropylamine**.
  - Example Calculation Note: Since **N-Isopropylpropylamine** has one active hydrogen, its equivalent weight is equal to its molecular weight (101.19 g/mol).

- Add the blend of DETA and **N-Isopropylpropylamine** to the pre-weighed epoxy resin and mix thoroughly.
- Casting and Curing:
  - Pour the mixed formulations into release-coated molds to create samples suitable for testing (e.g., thin films for flexibility, small pucks for DSC).
  - De-gas the samples in a vacuum chamber to remove entrapped air bubbles.
  - Cure the samples according to a standard cure schedule (e.g., 24 hours at 25°C followed by a post-cure of 2 hours at 80°C).
- Characterization and Analysis:
  - Thermal Analysis: Use Differential Scanning Calorimetry (DSC) to measure the glass transition temperature (T<sub>g</sub>) of each cured sample. A decrease in T<sub>g</sub> with increasing modifier concentration is expected, indicating a less densely crosslinked network.
  - Mechanical Testing: Perform a simple mandrel bend test on the cured thin films. An increase in the ability to bend around smaller diameter mandrels without cracking indicates improved flexibility. For more quantitative data, use a Dynamic Mechanical Analyzer (DMA) or tensile tester.

Expected Outcome: A systematic reduction in T<sub>g</sub> and an increase in flexibility as the concentration of **N-Isopropylpropylamine** increases, demonstrating its efficacy as a chain terminator and plasticizing agent.

## Part 2: Application in Polyurethane Systems — A Dual-Role Component

In polyurethane (PU) chemistry, the core reaction is the polyaddition of an isocyanate (containing -NCO groups) and a polyol (containing -OH groups).[8] This reaction is almost always facilitated by a catalyst, with tertiary amines being the industry standard.[9][10]

### Core Concept: Catalyst and Reactive Chain Modifier

**N-Isopropylpropylamine** can play a dual role in PU systems:

- **Catalyst:** While less common and generally less active than their tertiary counterparts, secondary amines can exhibit catalytic activity, promoting both the gelling (polyol-isocyanate) and blowing (water-isocyanate) reactions.[9][11] Their lower activity can be advantageous in applications requiring a slower cure profile or longer pot life.
- **Reactive Chain Modifier:** The N-H bond in **N-Isopropylpropylamine** is highly reactive with isocyanate groups (-NCO). This reaction is significantly faster than the polyol-isocyanate reaction and results in the formation of a urea linkage (-NH-CO-NH-).[8] This makes the amine a reactive participant, not just a catalyst. As it is monofunctional, it acts as a chain stopper, capping the isocyanate-terminated prepolymer and thereby controlling the final molecular weight of the polymer.

## Mechanism of Action: Urethane vs. Urea Formation

The presence of **N-Isopropylpropylamine** introduces a competing reaction pathway. While the bulk of the polymer forms urethane linkages, the secondary amine will react to form terminal urea groups.

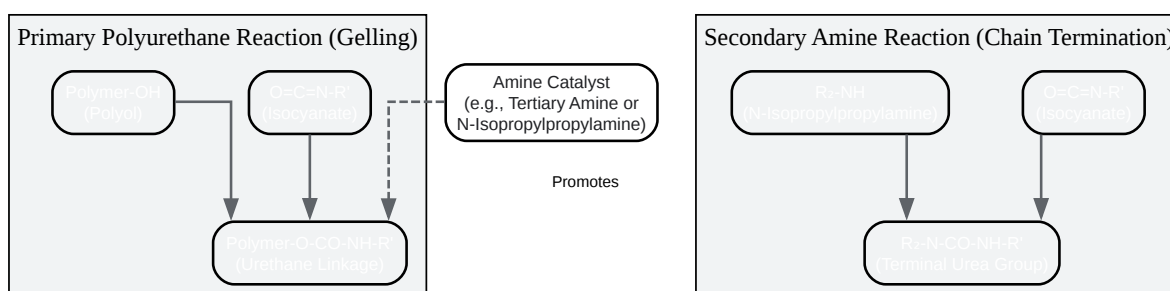

[Click to download full resolution via product page](#)

Caption: Competing urethane and urea formation reactions in a PU system.

## Experimental Workflow: Assessing Impact on a PU Coating

This workflow describes how to evaluate **N-Isopropylpropylamine**'s effect on the cure characteristics and hardness of a two-component polyurethane clear coat.

- **System Definition:** Select a standard 2K PU system, comprising an isocyanate component (e.g., HDI trimer) and a polyol component (e.g., a polyester or acrylic polyol), along with a standard tertiary amine catalyst package.
- **Variable Introduction:** Prepare a series of formulations where a portion of the standard catalyst is replaced by **N-Isopropylpropylamine** on a weight basis (e.g., 0%, 25%, 50% replacement). In a separate series, add small amounts (e.g., 0.1, 0.2, 0.5 phr) of **N-Isopropylpropylamine** as a reactive additive, keeping the primary catalyst level constant.
- **Process Monitoring:**
  - **Pot Life:** For each formulation, measure the pot life by recording the time until the viscosity of the mixed components doubles.
  - **Cure Time:** Apply films of a consistent thickness to test panels. Measure the tack-free time and through-cure time using a thumb-twist test or a mechanical cure recorder.
- **Property Evaluation:**
  - **Hardness:** After full curing (e.g., 7 days at 25°C), measure the pencil hardness (ASTM D3363) or König pendulum hardness (ASTM D4366) of the resulting films.
- **Data Analysis:** Correlate the concentration of **N-Isopropylpropylamine** with changes in pot life, cure speed, and final hardness. An increase in pot life would suggest lower catalytic activity compared to the standard catalyst. Changes in hardness will reflect the impact of urea group formation and molecular weight modification.

## Part 3: Application as a Corrosion Inhibitor in Coatings

Corrosion is an electrochemical process that degrades metals.[12] Protective coatings are the primary defense, and their efficacy can be significantly enhanced by incorporating corrosion inhibitors. Amine-based compounds are a well-established class of organic corrosion inhibitors.[13]

## Core Concept: Interfacial Adsorption and Barrier Formation

The effectiveness of **N-Isopropylpropylamine** as a corrosion inhibitor stems from the ability of its nitrogen atom to interact with the metal surface. The lone pair of electrons on the nitrogen atom can coordinate with vacant d-orbitals of the metal (e.g., iron), leading to adsorption of the molecule onto the surface.

This adsorbed layer acts as a protective barrier through two mechanisms:

- **Physical Barrier:** The bulky, hydrophobic alkyl (propyl and isopropyl) chains orient away from the metal surface, creating a non-polar film that repels water and other corrosive electrolytes.
- **Electrochemical Barrier:** The adsorbed amine can displace water molecules from the surface and block active sites where corrosion reactions would otherwise initiate.

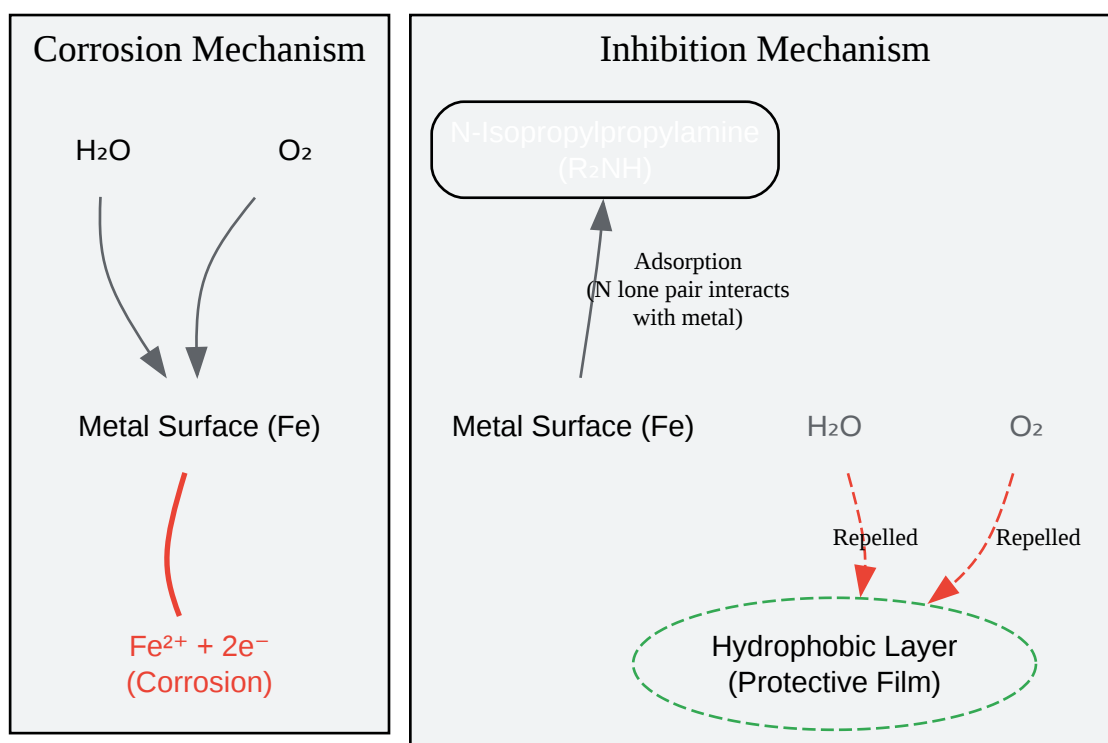

[Click to download full resolution via product page](#)

Caption: Mechanism of amine-based corrosion inhibition on a metal surface.

## Protocol: Formulation and Testing of an Inhibitive Primer

This protocol provides a framework for incorporating **N-Isopropylpropylamine** into a coating and evaluating its anti-corrosive performance.

Objective: To assess the effectiveness of **N-Isopropylpropylamine** as a corrosion inhibitor in a solvent-borne epoxy-polyamide primer.

Materials:

- Epoxy-polyamide primer formulation (two-component)
- **N-Isopropylpropylamine**
- Solvent for dilution (e.g., a blend of xylene and butanol)

- Steel test panels (e.g., cold-rolled steel, prepared as per ASTM D609)
- Salt spray cabinet (ASTM B117)

Procedure:

- Inhibitor Dosing: Prepare several batches of the primer's amine (polyamide) component.
  - Control: No added inhibitor.
  - Test Batches: Add **N-Isopropylpropylamine** at various concentrations (e.g., 0.5%, 1.0%, and 2.0% based on total resin solids). Ensure it is thoroughly mixed and fully dissolved.
- Panel Coating:
  - For each batch, mix the epoxy and modified amine components according to the manufacturer's ratio.
  - Apply the primer to prepared steel panels at a consistent dry film thickness (DFT), typically 50-75  $\mu\text{m}$ .
  - Allow panels to cure fully as per the data sheet (e.g., 7 days at 25°C).
- Scribing and Exposure:
  - Using a scribing tool, create a single straight scribe line down the center of each panel, ensuring the scribe penetrates the coating to the metal substrate.
  - Place the panels in a salt spray cabinet, oriented at the specified angle.
  - Expose the panels to a continuous 5% neutral salt fog according to ASTM B117 for a predetermined duration (e.g., 250, 500, or 1000 hours).
- Evaluation:
  - Periodically remove panels for inspection.

- Evaluate the panels according to ASTM D1654 for rust creepage from the scribe (measure the width of corrosion extending from the scribe line) and ASTM D714 for blistering on the panel face.
- Compare the performance of the test panels to the control. Reduced rust creepage and blistering indicate effective corrosion inhibition.

## Conclusion

**N-Isopropylpropylamine** is a multifunctional additive whose utility in coatings and plastics is derived from the nuanced chemistry of its secondary amine group. It is not a bulk building block but a precision tool for the formulation scientist. In epoxy systems, it acts as a chain terminator to control crosslink density and enhance flexibility. In polyurethanes, it serves a dual function as a potential catalyst and a reactive modifier that caps polymer chains and introduces robust urea linkages. Finally, in protective coatings, its molecular structure allows it to function as an effective corrosion inhibitor by forming a protective film on metal substrates. The illustrative protocols provided herein offer a clear, logical framework for researchers to systematically investigate and harness these properties to develop next-generation materials.

## References

- The Impact of Amine Catalyst Selection on PU Foam Properties and Performance. (n.d.). SpecialChem.
- The revolutionary role of amine catalysts in modern polyurethane foam manufacturing. (2025). BDMAEE.
- RESEARCH PROGRESS OF AMINE CATALYSTS FOR POLYURETHANE. (n.d.). ResearchGate. Available from: [\[Link\]](#)
- China Polyurethane Amine Catalysts Exporter & Suppliers. (n.d.). Mofan Block Co., Ltd. Available from: [\[Link\]](#)
- Curing Agents for Epoxy Resin. (n.d.). ThreeBond Technical News. Available from: [\[Link\]](#)
- Summary of types and curing mechanisms of epoxy resin curing agents. (2024). Knowledge. Available from: [\[Link\]](#)

- The Chemistry Behind Amine-Cured Epoxy Systems. (2025). Epoxy Flooring Co. Available from: [\[Link\]](#)
- Corrosion inhibitors. (1992). Google Patents.
- Corrosion inhibiting compositions and method for metal substrates. (2003). Google Patents.
- **N-Isopropylpropylamine** | C<sub>6</sub>H<sub>15</sub>N | CID 89119. (n.d.). PubChem, National Center for Biotechnology Information. Available from: [\[Link\]](#)
- **N-ISOPROPYLPROPYLAMINE** CAS#: 21968-17-2. (n.d.). ChemWhat. Available from: [\[Link\]](#)

### Need Custom Synthesis?

BenchChem offers custom synthesis for rare earth carbides and specific isotopic labeling.

Email: [info@benchchem.com](mailto:info@benchchem.com) or [Request Quote Online](#).

## Sources

1. N-Isopropylpropylamine | C<sub>6</sub>H<sub>15</sub>N | CID 89119 - PubChem [[pubchem.ncbi.nlm.nih.gov](https://pubchem.ncbi.nlm.nih.gov)]
2. 21968-17-2 CAS MSDS (N-ISOPROPYLPROPYLAMINE) Melting Point Boiling Point Density CAS Chemical Properties [[chemicalbook.com](https://chemicalbook.com)]
3. Polyurethane Amine Catalysts Manufacturers - China Polyurethane Amine Catalysts Exporter & Suppliers [[mofanpu.com](https://mofanpu.com)]
4. chemwhat.com [[chemwhat.com](https://chemwhat.com)]
5. Summary of types and curing mechanisms of epoxy resin curing agents - Knowledge [[dinuofrp.com](https://dinuofrp.com)]
6. hanepoxy.net [[hanepoxy.net](https://hanepoxy.net)]
7. threebond.co.jp [[threebond.co.jp](https://threebond.co.jp)]
8. l-i.co.uk [[l-i.co.uk](https://l-i.co.uk)]
9. The Impact of Amine Catalyst Selection on PU Foam Properties and Performance – T&C Chem International Marketing, Sales and Distribution Company [[tncintlchem.com](https://tncintlchem.com)]
10. bdmaee.net [[bdmaee.net](https://bdmaee.net)]
11. researchgate.net [[researchgate.net](https://researchgate.net)]
12. Corrosion inhibitors - Patent 0526251 [[data.epo.org](https://data.epo.org)]

- [13. EP1505177A1 - Corrosion inhibiting compositions and method for metal substrates - Google Patents \[patents.google.com\]](#)
- To cite this document: BenchChem. [Introduction: N-Isopropylpropylamine as a Versatile Modifier in Polymer Chemistry]. BenchChem, [2026]. [Online PDF]. Available at: [<https://www.benchchem.com/product/b1583633/docs#introduction-n-isopropylpropylamine-as-a-versatile-modifier-in-polymer-chemistry>]

---

**Disclaimer & Data Validity:**

The information provided in this document is for Research Use Only (RUO) and is strictly not intended for diagnostic or therapeutic procedures. While BenchChem strives to provide accurate protocols, we make no warranties, express or implied, regarding the fitness of this product for every specific experimental setup.

**Technical Support:** The protocols provided are for reference purposes. Unsure if this reagent suits your experiment?

**Need Industrial/Bulk Grade?** [Request Custom Synthesis Quote](#)

## BenchChem

Our mission is to be the trusted global source of essential and advanced chemicals, empowering scientists and researchers to drive progress in science and industry.

### Contact

Address: 3281 E Guasti Rd  
Ontario, CA 91761, United States  
Phone: (601) 213-4426  
Email: [info@benchchem.com](mailto:info@benchchem.com)

[Contact our Ph.D. Support Team for a compatibility check](#)