

Technical Support Center: Dichloro-methyl-octadecylsilane (DMODS) Surface Modification

Author: BenchChem Technical Support Team. **Date:** May 2026

Compound of Interest

Compound Name: *Dichloro-methyl-octadecylsilane*

CAS No.: *5157-75-5*

Cat. No.: *B1582506*

[Get Quote](#)

A Guide for Researchers, Scientists, and Drug Development Professionals

Introduction to DMODS Silanization

Dichloro-methyl-octadecylsilane (DMODS) is a bifunctional organosilane commonly used to create hydrophobic, self-assembled monolayers (SAMs) on hydroxylated surfaces such as glass, silicon wafers, and other metal oxides. The formation of a dense, well-ordered monolayer is a multi-step process involving the hydrolysis of the chlorosilane groups in the presence of trace water, followed by condensation with surface hydroxyl groups and subsequent lateral polymerization with adjacent silane molecules. Incomplete or poor-quality coverage is a frequent issue that can significantly impact downstream applications. This guide will help you diagnose and resolve these common problems.

Troubleshooting Guide: Incomplete Surface Coverage

Question: I am observing patchy or incomplete hydrophobic coating on my substrate. What are the

likely causes and how can I fix this?

This is the most common failure mode in DMODS silanization. The root cause often lies in one or more of the following critical areas:

- **Substrate Cleanliness and Hydroxylation:** The density of reactive hydroxyl (-OH) groups on the substrate surface is paramount for a dense SAM.
- **Water Content in the Reaction Environment:** Trace amounts of water are essential for the hydrolysis of the Si-Cl bonds, but excessive water leads to premature polymerization in solution.
- **Silane Quality and Handling:** DMODS is highly reactive and susceptible to degradation.
- **Reaction Conditions:** Time, temperature, and solvent choice play a significant role in the kinetics of monolayer formation.

Below is a systematic approach to troubleshooting these factors.

FAQ 1: How does substrate preparation affect DMODS monolayer formation?

Answer: Substrate preparation is arguably the most critical step for achieving a high-quality DMODS monolayer. The goal is two-fold: to remove all organic and inorganic contaminants and to ensure a high density of surface hydroxyl groups.

The Causality: The silicon atom in DMODS forms a covalent siloxane (Si-O-Si) bond with the hydroxyl groups on the substrate. If the surface is contaminated with oils, dust, or other residues, it will physically mask the hydroxyl groups, preventing the silane from attaching and leading to pinholes and uncoated areas in the final monolayer. Inconsistent cleaning can also result in a non-uniform distribution of hydroxyl groups, leading to a patchy coating. Harsh cleaning procedures can sometimes increase surface roughness, which may affect the final contact angle of the coating[1].

Recommended Substrate Cleaning and Activation Protocol:

- Initial Cleaning:
 - Sonication in a series of solvents of decreasing polarity is effective for removing organic contaminants. A typical sequence is:
 1. Acetone (15 minutes)
 2. Isopropanol (15 minutes)
 3. Deionized (DI) water (15 minutes)
 - Thoroughly rinse with DI water between each solvent wash.
- Surface Activation (Hydroxylation):
 - The goal is to generate a high density of Si-OH groups on the surface. Common methods include:
 - Piranha Solution: A 3:1 mixture of concentrated sulfuric acid (H_2SO_4) and 30% hydrogen peroxide (H_2O_2).
 - Caution: Piranha solution is extremely corrosive and reactive. It must be handled with extreme care in a fume hood with appropriate personal protective equipment (PPE). Never store it in a sealed container.
 - Immerse the cleaned substrate in freshly prepared Piranha solution for 15-30 minutes.
 - Rinse copiously with DI water.
 - Plasma Treatment: Oxygen or argon plasma cleaning is a highly effective and less hazardous alternative to Piranha solution. It both cleans and activates the surface.
 - UV/Ozone Treatment: Exposure to UV light in the presence of ozone is another effective method for removing organic contaminants and generating hydroxyl groups.
- Final Rinse and Drying:

- After activation, rinse the substrate thoroughly with DI water.
- Dry the substrate under a stream of high-purity nitrogen or in a vacuum oven at a moderate temperature (e.g., 80-100 °C). The substrate must be completely dry before being introduced to the silane solution.

FAQ 2: What is the role of water in the DMODS reaction, and how do I control it?

Answer: Water plays a dual and critical role in the formation of a DMODS monolayer. It is both a necessary reactant and a potential source of unwanted side reactions.

The Mechanism: The silanization process occurs in two main steps:

- Hydrolysis: The two chloro groups (-Cl) on the DMODS molecule react with trace water to form silanol groups (-OH). This is a necessary activation step.^{[2][3]}
- Condensation: These newly formed silanol groups then react (condense) with the hydroxyl groups on the substrate surface to form stable Si-O-Si bonds. Additionally, adjacent hydrolyzed DMODS molecules can condense with each other, forming a cross-linked polymer network on the surface.

The Problem with Excess Water: If there is too much water in the reaction solvent or on the substrate surface, the DMODS molecules will preferentially hydrolyze and polymerize in the solution before they have a chance to attach to the surface. This leads to the formation of insoluble polysiloxane aggregates that can deposit on the surface, resulting in a rough, non-uniform, and poorly adhered coating.^[4]

Controlling Water Content:

- Use Anhydrous Solvents: The organic solvent (e.g., toluene, hexane, or chloroform) used to dissolve the DMODS should be of high purity and anhydrous. Using a freshly opened bottle or a solvent from a solvent purification system is recommended.
- Dry Substrate: As mentioned in the previous section, ensure the substrate is completely dry before immersion in the silane solution.

- **Inert Atmosphere:** For the most sensitive applications, performing the reaction under an inert atmosphere (e.g., nitrogen or argon) can help to exclude atmospheric moisture. Backfilling the reaction vessel with an inert gas can be beneficial.
- **Controlled Humidity Environment:** Some protocols for other chlorosilanes, particularly trichlorosilanes, have found that a controlled, low-humidity environment can be beneficial for forming a well-ordered monolayer. However, for dichlorosilanes, the primary focus should be on minimizing excess water in the solvent.

FAQ 3: My DMODS solution appears cloudy, or I see white precipitates on my substrate. What's wrong?

Answer: A cloudy solution or the presence of white precipitates is a clear indication of premature hydrolysis and polymerization of the DMODS in the bulk solution.

The Causality: This is a direct consequence of excessive water in your reaction system. The DMODS has reacted with water to form large, insoluble polysiloxane networks. These aggregates will not form a uniform monolayer and will instead deposit randomly on your surface, leading to a rough and incomplete coating.

Troubleshooting Steps:

- **Discard the Solution:** Do not attempt to use a cloudy or precipitated DMODS solution. It will not yield a good quality monolayer.
- **Review Your Solvent Handling:**
 - Are you using a new, unopened bottle of anhydrous solvent?
 - If using a solvent from a larger container, was it properly sealed to prevent moisture ingress?
 - Consider using a molecular sieve to dry your solvent before use, but be aware that this can introduce dust particles if not handled correctly.
- **Check Your Silane:**

- DMODS is highly sensitive to moisture. Ensure the bottle was tightly capped and stored in a desiccator.
- If the silane is old or has been opened multiple times, it may be compromised. It is often best to use a fresh vial.
- Clean and Dry Glassware: Ensure all glassware used for preparing the solution is scrupulously clean and oven-dried before use.

FAQ 4: How do reaction time and silane concentration affect the final coverage?

Answer: Both reaction time and silane concentration are key kinetic parameters that need to be optimized for your specific substrate and application.

The Interplay of Factors:

- Concentration: A higher concentration of DMODS can lead to a faster reaction rate. However, excessively high concentrations can increase the likelihood of multilayer formation and the deposition of aggregates on the surface. A common starting concentration is in the range of 0.1% to 2% (v/v) in an anhydrous solvent.
- Time: The self-assembly process is not instantaneous. While initial binding to the surface can be rapid, the formation of a well-ordered, cross-linked monolayer takes time. Insufficient reaction time will result in a low-density, incomplete monolayer. Conversely, excessively long reaction times, especially at higher concentrations, can also contribute to the formation of undesirable multilayers. Typical reaction times range from 30 minutes to several hours.

Optimization Strategy:

A design of experiments (DOE) approach can be beneficial for optimizing these parameters.^[5] ^[6] However, a simpler approach is to systematically vary one parameter while keeping the other constant.

Parameter	Low Setting	High Setting	Potential Outcome
Concentration	0.1% (v/v)	2% (v/v)	Higher concentration can speed up the initial reaction but may lead to aggregates.
Time	30 minutes	4 hours	Longer times generally improve monolayer packing and ordering, but can lead to multilayers if other conditions are not optimal.

Recommendation: Start with a mid-range condition (e.g., 1% DMODS for 1-2 hours) and then adjust based on the results of your surface characterization.

Visualizing the DMODS Silanization Workflow

The following diagram illustrates the key steps and decision points in the DMODS coating process.

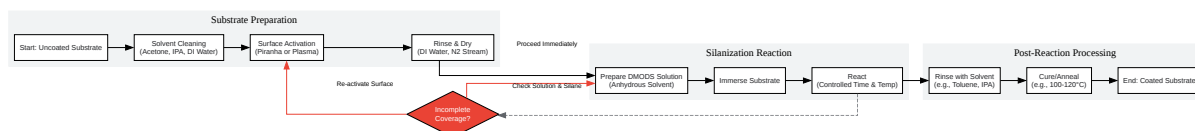

[Click to download full resolution via product page](#)

Caption: Workflow for DMODS surface modification with troubleshooting loops.

The Chemistry of DMODS Monolayer Formation

The following diagram illustrates the chemical reactions occurring at the substrate surface during silanization.

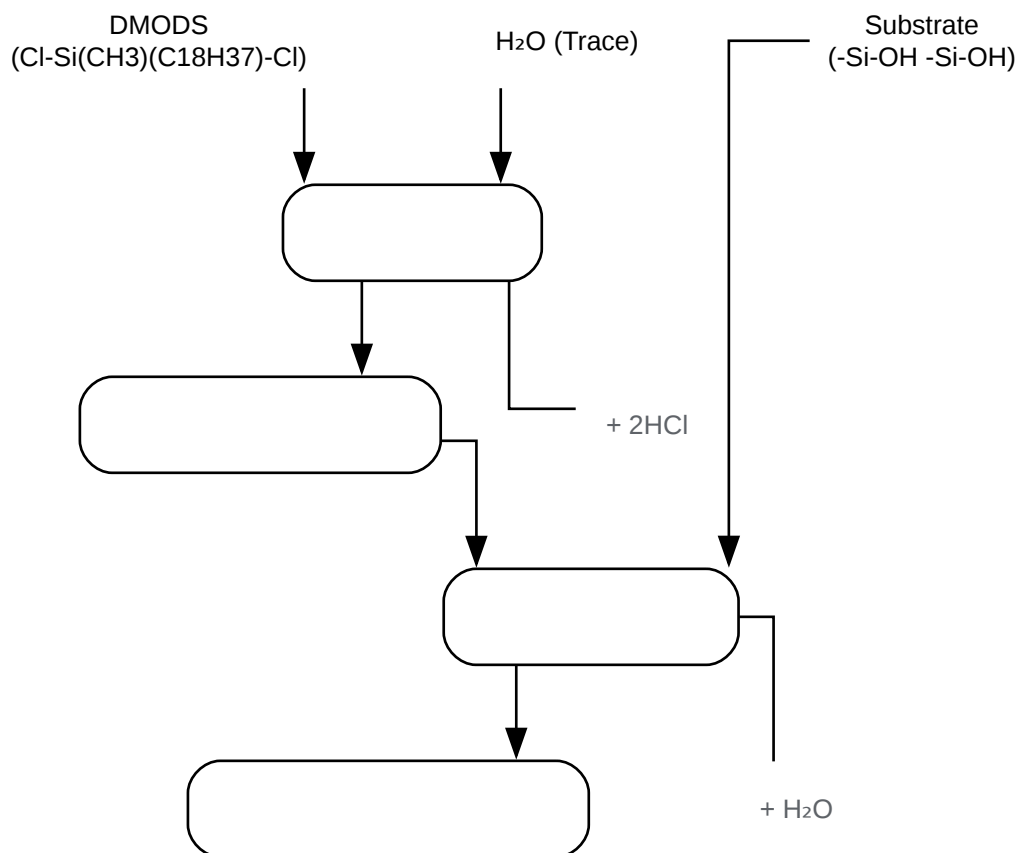

[Click to download full resolution via product page](#)

Caption: Reaction mechanism of DMODS with a hydroxylated surface.

Characterization of Monolayer Quality

To troubleshoot effectively, you need methods to assess the quality of your DMODS coating.

Technique	Information Provided
Contact Angle Goniometry	Measures the hydrophobicity of the surface. A high static water contact angle (typically $>100^\circ$ for a good DMODS monolayer) indicates successful coating. Low or variable contact angles suggest incomplete coverage.[4]
Atomic Force Microscopy (AFM)	Provides topographical information about the surface. A high-quality monolayer should be smooth. The presence of large aggregates or pinholes indicates a poor coating.[7]
X-ray Photoelectron Spectroscopy (XPS)	A surface-sensitive technique that provides elemental composition. A successful coating will show an increase in the carbon signal and the presence of silicon, while the signal from the underlying substrate will be attenuated. The absence of a chlorine peak indicates complete hydrolysis.[4]
Ellipsometry	Measures the thickness of the deposited film. For a monolayer, the thickness should be consistent with the length of the octadecyl chain (approx. 2-2.5 nm).[8]

References

- [Vertex AI Search Result\[2\]](#)
- [Vertex AI Search Result\[9\]](#)
- [Vertex AI Search Result\[10\]](#)
- Shah, K. et al. (2023). Systematic Study of Wettability Alteration of Glass Surfaces by Dichlorooctamethyltetrasiloxane Silanization: A Guide for Contact Angle Modification. ACS Omega. [[Link](#)]
- [Vertex AI Search Result\[11\]](#)

- Vertex AI Search Result[12]
- Brinker, C. J. (1988). Hydrolysis and condensation of silicates: Effects on structure. Journal of Non-Crystalline Solids.
- Stat-Ease. (n.d.). Design of Experiments Helps Optimize Pharmaceutical Coating Process. Stat-Ease. [Link]
- Galy, J. et al. (2018). Surface Modification of Porous Silicon-Based Films Using Dichlorosilanes Dissolved in Supercritical Carbon Dioxide. Industrial & Engineering Chemistry Research. [Link]
- Vertex AI Search Result[13]
- Vertex AI Search Result[14]
- Wang, Y. et al. (2010). Self-assembly of octadecyltrichlorosilane monolayers on silicon-based substrates by chemical vapor deposition. RSC Advances. [Link]
- Vertex AI Search Result[15]
- Vertex AI Search Result[16]
- Zhang, H. et al. (2014). Construction of octadecyltrichlorosilane self-assembled monolayer on stainless steel 316L surface. Applied Surface Science. [Link]
- Vertex AI Search Result[17]
- Vertex AI Search Result[18]
- Vertex AI Search Result[19]
- Vertex AI Search Result[20]
- Vertex AI Search Result[21]
- Patel, K. et al. (2015). Optimization of coating process parameters by design of experiment (DOE). ResearchGate. [Link]

- [Vertex AI Search Result\[22\]](#)
- [Vertex AI Search Result\[23\]](#)
- Sharma, S. et al. (2017). Characterization of Self-Assembled Monolayers on a Ruthenium Surface. Langmuir. [[Link](#)]
- [Vertex AI Search Result\[24\]](#)

Need Custom Synthesis?

BenchChem offers custom synthesis for rare earth carbides and specific isotopic labeling.

Email: info@benchchem.com or [Request Quote Online](#).

Sources

- [1. pubs.acs.org](https://pubs.acs.org) [pubs.acs.org]
- [2. researchgate.net](https://researchgate.net) [researchgate.net]
- [3. brinkerlab.unm.edu](https://brinkerlab.unm.edu) [brinkerlab.unm.edu]
- [4. researchgate.net](https://researchgate.net) [researchgate.net]
- [5. cdn.statease.com](https://cdn.statease.com) [cdn.statease.com]
- [6. researchgate.net](https://researchgate.net) [researchgate.net]
- [7. researchgate.net](https://researchgate.net) [researchgate.net]
- [8. pubs.acs.org](https://pubs.acs.org) [pubs.acs.org]
- [9. A novel tool for the unbiased characterization of epithelial monolayer development in culture - PMC](#) [[pmc.ncbi.nlm.nih.gov](https://pubmed.ncbi.nlm.nih.gov/)]
- [10. researchgate.net](https://researchgate.net) [researchgate.net]
- [11. researchgate.net](https://researchgate.net) [researchgate.net]
- [12. researchgate.net](https://researchgate.net) [researchgate.net]
- [13. Mass Spectrometry of Self-Assembled Monolayers: A New Tool for Molecular Surface Science - PMC](#) [[pmc.ncbi.nlm.nih.gov](https://pubmed.ncbi.nlm.nih.gov/)]
- [14. Optimization of Coating Process Parameters by Analysis of Target Powder Thickness and Regression Modeling | MDPI](#) [mdpi.com]

- [15. researchgate.net \[researchgate.net\]](#)
- [16. Separating Octadecyltrimethoxysilane Hydrolysis and Condensation at the Air/Water Interface through Addition of Methyl Stearate - PMC \[pmc.ncbi.nlm.nih.gov\]](#)
- [17. researchgate.net \[researchgate.net\]](#)
- [18. youtube.com \[youtube.com\]](#)
- [19. researchgate.net \[researchgate.net\]](#)
- [20. pasi.mech.northwestern.edu \[pasi.mech.northwestern.edu\]](#)
- [21. How to optimize coating application through surface preparation? – Sandblasting Material Manufacturer \[hlh-js.com\]](#)
- [22. researchgate.net \[researchgate.net\]](#)
- [23. researchgate.net \[researchgate.net\]](#)
- [24. Hydrolytic stability of terephthaloyl chloride and isophthaloyl chloride - PubMed \[pubmed.ncbi.nlm.nih.gov\]](#)
- [To cite this document: BenchChem. \[Technical Support Center: Dichloro-methyl-octadecylsilane \(DMODS\) Surface Modification\]. BenchChem, \[2026\]. \[Online PDF\]. Available at: \[https://www.benchchem.com/product/b1582506/docs#technical-support-center-dichloro-methyl-octadecylsilane-dmods-surface-modification\]](#)

Disclaimer & Data Validity:

The information provided in this document is for Research Use Only (RUO) and is strictly not intended for diagnostic or therapeutic procedures. While BenchChem strives to provide accurate protocols, we make no warranties, express or implied, regarding the fitness of this product for every specific experimental setup.

Technical Support: The protocols provided are for reference purposes. Unsure if this reagent suits your experiment?

Need Industrial/Bulk Grade? [Request Custom Synthesis Quote](#)

BenchChem

Our mission is to be the trusted global source of essential and advanced chemicals, empowering scientists and researchers to drive progress in science and industry.

Contact

Address: 3281 E Guasti Rd

Ontario, CA 91761, United States

Phone: (601) 213-4426

Email: info@benchchem.com

[Contact our Ph.D. Support Team for a compatibility check](#)