

# Precision Synthesis of Functionalized Dichlorobenzenes: A Comparative Guide

**Author:** BenchChem Technical Support Team. **Date:** May 2026

## Compound of Interest

Compound Name: *1,3-Dichloro-2-(methoxymethyl)benzene*

CAS No.: 33486-90-7

Cat. No.: B1582421

[Get Quote](#)

## Executive Summary

Functionalized dichlorobenzenes (DCBs) are critical pharmacophores in medicinal chemistry, serving as core scaffolds for non-steroidal anti-inflammatory drugs (e.g., Diclofenac), antifungal agents, and herbicides. The introduction of two chlorine atoms into an aromatic ring creates unique steric and electronic environments, often improving metabolic stability and lipophilicity.

However, synthesizing these scaffolds with high regiocontrol is notoriously difficult due to the directing effects of existing substituents. This guide compares three distinct synthetic methodologies:

- Oxidative Chlorination (Green EAS): Best for electron-rich substrates and 2,4-substitution patterns.
- The Sandmeyer Route: The gold standard for "impossible" substitution patterns (e.g., 2,6-isomers) and removing activating groups.

- Directed Ortho-Metalation (DoM): The modern approach for site-selective functionalization of existing dichlorobenzenes.

## Decision Matrix: Selecting the Optimal Route

Before detailing protocols, use this decision matrix to identify the method best suited for your target scaffold.

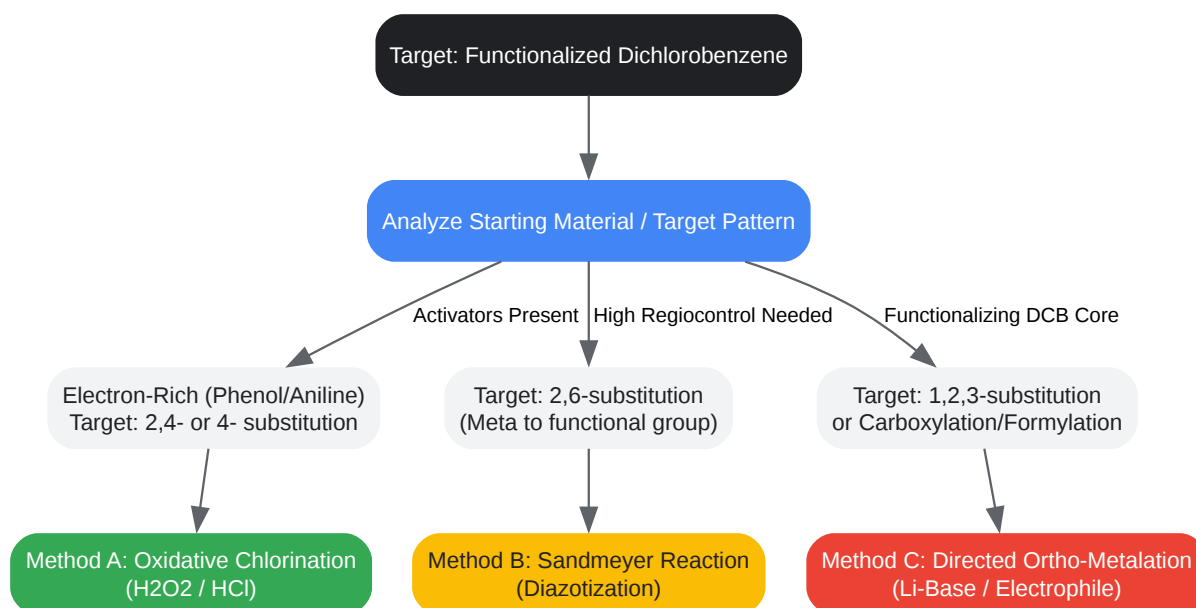

[Click to download full resolution via product page](#)

Figure 1: Strategic decision tree for selecting the synthetic route based on substrate electronics and desired regiochemistry.

## Comparative Analysis of Synthetic Routes

### Method A: Oxidative Chlorination (Green EAS)

Traditional chlorination uses

gas, which is hazardous and difficult to meter for stoichiometry. The modern "Green" alternative utilizes oxidative chlorination with

and

[1] This generates "Cl+" in situ, offering milder conditions and higher selectivity for para-chlorination.

- Mechanism: Electrophilic Aromatic Substitution (EAS).[2]
- Best For: Synthesis of 2,4-dichlorophenol or 2,4-dichloroaniline.
- Pros: High atom economy, water as the primary byproduct, scalable.
- Cons: Limited to ortho/para directing groups; difficult to stop at mono-chlorination without optimization.

## Method B: The Sandmeyer Reaction

When the desired substitution pattern contradicts standard electronic directing effects (e.g., placing chlorines meta to each other or ortho to a group that usually directs para), the Sandmeyer reaction is indispensable. It typically involves chlorinating an aniline intermediate and then converting the amine to a chlorine (or other group) via a diazonium salt.[3]

- Mechanism: Radical-Nucleophilic Aromatic Substitution ( ) via copper catalysis.
- Best For: Synthesis of 2,6-dichloro derivatives (e.g., 2,6-dichlorobenzonitrile).
- Pros: Access to "forbidden" substitution patterns; extremely high fidelity.
- Cons: Stoichiometric copper waste; handling of potentially explosive diazonium intermediates.

## Method C: Directed Ortho-Metalation (DoM)

DoM allows for the functionalization of a dichlorobenzene ring after the chlorines are already in place.[4] By using a Directing Metalation Group (DMG) and a strong base (e.g., n-BuLi), the proton ortho to the DMG is selectively removed, allowing reaction with electrophiles (

- ).
- Mechanism: Complex Induced Proximity Effect (CIPE).[5]
  - Best For: Creating 2,6-dichlorobenzoic acid or functionalized 1,3-dichlorobenzenes.
  - Pros: Unmatched regioselectivity for contiguous substitution patterns (1,2,3-).
  - Cons: Requires cryogenic conditions (-78°C), moisture-sensitive organolithiums, and inert atmosphere.

## Performance Data Comparison

Metric	Oxidative Chlorination (EAS)	Sandmeyer Reaction	Directed Ortho-Metalation (DoM)
Target Regioselectivity	Ortho/Para (2,4-)	Ipsso (Replacement)	Ortho to DMG (1,2,3-)
Typical Yield	85 - 96%	60 - 80%	70 - 90%
Atom Economy	High	Low (Loss of )	Moderate
Safety Profile	Moderate (Peroxides)	Low (Diazonium/Explosion risk)	Low (Pyrophoric Li-bases)
Cost Efficiency	High (Cheap reagents)	Moderate	Low (Expensive bases/cooling)
Green Score	High (Water byproduct)	Low (Cu waste)	Moderate (Solvent intensity)

## Detailed Experimental Protocols

### Protocol A: Synthesis of 2,4-Dichlorophenol (Oxidative Chlorination)

Based on catalytic oxidative chlorination principles [1].

Reagents: Phenol (1.0 eq), 35% HCl (2.2 eq), 30%

(2.2 eq), Methanol (Solvent).

- Dissolution: Dissolve phenol (9.4 g, 0.1 mol) in methanol (50 mL) in a round-bottom flask equipped with a reflux condenser and addition funnel.

- Acidification: Add 35% HCl (23 g) to the solution while stirring at room temperature.

- Oxidation (Critical Step): Slowly add 30%

dropwise over 60 minutes. Note: The reaction is exothermic; maintain temperature < 40°C using a water bath.

- Reaction: Stir for 4 hours at 40°C. Monitor by TLC (Hexane/EtOAc 8:2) for the disappearance of monochlorophenol intermediates.

- Workup: Quench with saturated

solution to destroy excess peroxide. Extract with Ethyl Acetate (3 x 50 mL).

- Purification: Dry organic layer over

, filter, and concentrate. Recrystallize from hexane to yield white needles.

## Protocol B: Synthesis of 2,6-Dichloroaniline (Chlorination + Reduction)

A specialized route to access the 2,6-pattern often required for Sandmeyer downstream [2].

Reagents: Sulfanilamide (Blocking group strategy), HCl,

, NaOH.

- Protection: Start with sulfanilamide to block the para position.

- Chlorination: Treat sulfanilamide with concentrated HCl and

(30%) at 50-60°C. The amino group directs ortho, and the sulfonamide blocks para, forcing chlorination to the 2 and 6 positions.

- Hydrolysis (Deprotection): Reflux the intermediate (3,5-dichloro-4-aminobenzenesulfonamide) in 70% followed by steam distillation.
- Isolation: The sulfonic acid group is cleaved, yielding 2,6-dichloroaniline.
- Validation:  
NMR should show a doublet (aromatic protons) and a broad singlet ( ).

## Protocol C: Synthesis of 2,6-Dichlorobenzoic Acid (DoM)

Functionalizing 1,3-dichlorobenzene [3].

Reagents: 1,3-Dichlorobenzene, n-Butyllithium (2.5 M in hexanes), Dry THF, Dry (gas or dry ice).

- Setup: Flame-dry a 250 mL Schlenk flask under Argon. Add 1,3-dichlorobenzene (1.0 eq) and anhydrous THF. Cool to  $-78^{\circ}\text{C}$  (Dry ice/Acetone bath).
- Lithiation: Add n-BuLi (1.1 eq) dropwise via syringe pump over 30 minutes. Crucial: Maintain temp  $< -70^{\circ}\text{C}$  to prevent "benzyne" formation (elimination).
- Equilibration: Stir at  $-78^{\circ}\text{C}$  for 1 hour. The Lithium species forms at the C-2 position (between the two chlorines) due to the inductive effect of the halogens.
- Quench: Bubble dry gas into the solution for 30 minutes, or pour the reaction mixture onto crushed dry ice.
- Workup: Allow to warm to RT. Acidify with 2M HCl to pH 1. Extract with diethyl ether.
- Purification: Extract the ether layer with 1M NaOH (separating the acid product from unreacted starting material). Re-acidify the aqueous layer to precipitate 2,6-dichlorobenzoic acid.

## Mechanistic Visualization

Understanding the difference in selectivity between EAS and DoM is vital for route design.

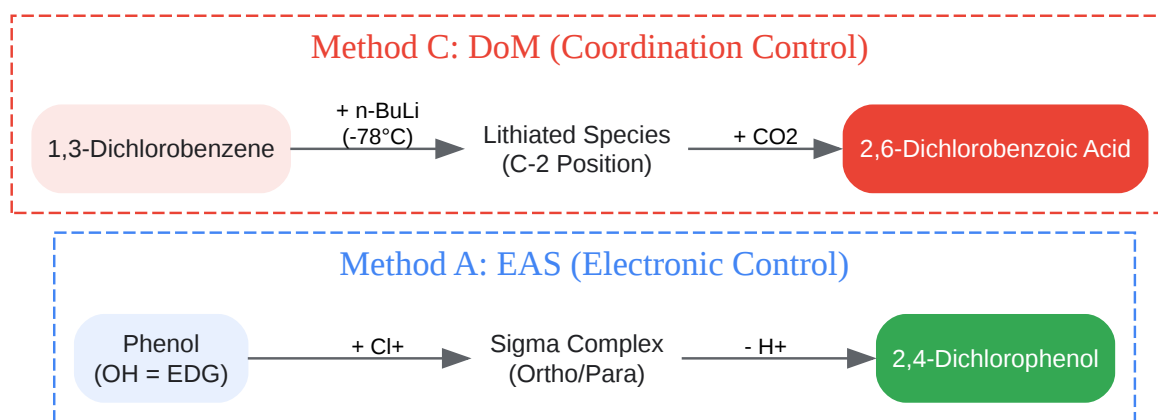

[Click to download full resolution via product page](#)

Figure 2: Mechanistic divergence. EAS relies on electronic resonance donation (OH group), typically yielding 2,4-isomers. DoM relies on inductive acidification and coordination, allowing access to the sterically congested 2-position in 1,3-dichlorobenzene.

## References

- Xin, H., et al. (2017).[6] "Selective water-based oxychlorination of phenol with hydrogen peroxide catalyzed by manganous sulfate." [1][6] RSC Advances.
- Seikel, M. K. (1944).[7] "2,6-Dichloroaniline." [7][8] Organic Syntheses, Coll. Vol. 3, p.262.
- Snieckus, V. (1990). "Directed ortho metalation. Tertiary amide and O-carbamate directors in synthetic strategies for polysubstituted aromatics." Chemical Reviews, 90(6), 879–933.
- BenchChem. (2025).[3][4] "Application Notes and Protocols: Directed ortho-Metalation of Dichlorobenzene Derivatives."

### Need Custom Synthesis?

BenchChem offers custom synthesis for rare earth carbides and specific isotopic labeling.

Email: [info@benchchem.com](mailto:info@benchchem.com) or [Request Quote Online](#).

## Sources

- [1. researchgate.net \[researchgate.net\]](#)
- [2. masterorganicchemistry.com \[masterorganicchemistry.com\]](#)
- [3. pdf.benchchem.com \[pdf.benchchem.com\]](#)
- [4. pdf.benchchem.com \[pdf.benchchem.com\]](#)
- [5. baranlab.org \[baranlab.org\]](#)
- [6. Selective water-based oxychlorination of phenol with hydrogen peroxide catalyzed by manganous sulfate - RSC Advances \(RSC Publishing\) DOI:10.1039/C7RA00319F \[pubs.rsc.org\]](#)
- [7. orgsyn.org \[orgsyn.org\]](#)
- [8. CN103524358A - Synthetic method of 2, 6-dichloroaniline - Google Patents \[patents.google.com\]](#)
- To cite this document: BenchChem. [Precision Synthesis of Functionalized Dichlorobenzenes: A Comparative Guide]. BenchChem, [2026]. [Online PDF]. Available at: [\[https://www.benchchem.com/product/b1582421/docs#precision-synthesis-of-functionalized-dichlorobenzenes-a-comparative-guide\]](https://www.benchchem.com/product/b1582421/docs#precision-synthesis-of-functionalized-dichlorobenzenes-a-comparative-guide)

---

### Disclaimer & Data Validity:

The information provided in this document is for Research Use Only (RUO) and is strictly not intended for diagnostic or therapeutic procedures. While BenchChem strives to provide accurate protocols, we make no warranties, express or implied, regarding the fitness of this product for every specific experimental setup.

**Technical Support:** The protocols provided are for reference purposes. Unsure if this reagent suits your experiment?

**Need Industrial/Bulk Grade?** [Request Custom Synthesis Quote](#)

# BenchChem

Our mission is to be the trusted global source of essential and advanced chemicals, empowering scientists and researchers to drive progress in science and industry.

## Contact

Address: 3281 E Guasti Rd

Ontario, CA 91761, United States

Phone: (601) 213-4426

Email: [info@benchchem.com](mailto:info@benchchem.com)

[Contact our Ph.D. Support Team for a compatibility check](#)